

GG6000

Operation and Maintenance Manual

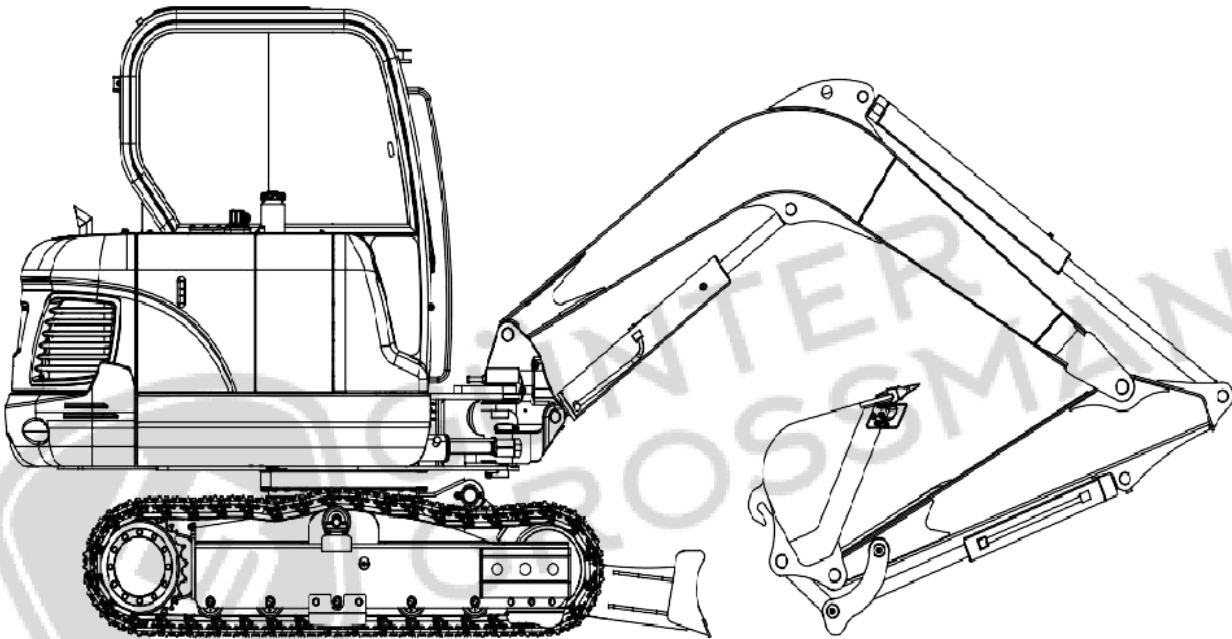

Günter Grossmann reserves the right to improve our products in a continuing process to provide the best possible product to the market place. These improvements can be implemented at any time with no obligation to change materialson previously sold products.

This documentation may include attachments and optional equipment that is not available in your machine's package. Please call your distributor for additional items that you may require.

Illustrations used throughout this manual are used only as a representation of the actual piece of equipment, and may vary from the actual item.



GÜNTER
GROSSMANN

Table of Contents

Safety	1-1
To the Operator of a <i>Günter Grossmann</i> Excavator.....	1-1
Location of Safety Labels	1-4
Visibility Information.....	1-13
Summary of Safety Precautions for Lifting in Digging Mode.....	1-15
Unauthorized Modifications	1-16
General Hazard Information.....	1-16
Before Starting Engine	1-25
Machine Operation	1-29
Maintenance	1-35
Battery	1-44
Towing.....	1-46
Shipping and Transportation.....	1-47
Excavator Rated Lift Capacity Tables.....	1-48
Operating Controls	2-1
Component Locations	2-2
Operator's Area	2-4
Operational Controls and Panels.....	2-6
Instrument Panel.....	2-16
Heater and Air Conditioner System.....	2-23
Stereo	2-28
Fuse Boxes.....	2-29
Miscellaneous Electrical Devices	2-30
Seat Adjustment.....	2-32
Front Windows	2-36
Door Side Latch	2-37
Cabin Storage Compartments.....	2-38
Sun Visor (Optional)	2-38
Hanger.....	2-39

Emergency Glass Breaking Tool.....	2-39
------------------------------------	------

Operation.....	3-1
-----------------------	------------

To Handle a New Excavator.....	3-1
Starting and Stopping the Engine.....	3-2
Safety Lever.....	3-14
Travel.....	3-15
Operating Instructions.....	3-20
Operating Precautions.....	3-24
Parking Excavator.....	3-29
Towing Procedure.....	3-30
Hydraulic Breaker.....	3-31
Operating Techniques.....	3-38
Operation Under Unusual Conditions.....	3-40

Inspection, Maintenance and Adjustment.....	4-1
--	------------

Preventive Maintenance.....	4-1
Preliminary Work Machine Setup for Maintenance.....	4-3
Table of Recommended Lubricants.....	4-5
Fluid Capacities.....	4-7
Lubrication and Service Chart.....	4-7
Maintenance Intervals.....	4-10
10 Hour / Daily Service.....	4-12
50 Hour / Weekly Service.....	4-19
250 Hour / Monthly Service.....	4-22
500 Hour / 3 Month Service.....	4-30
1,000 Hour / 6 Month Service.....	4-39
2,000 Hour / Yearly Service.....	4-45
Bolt and Nut Inspection.....	4-49
Bucket.....	4-54

K1037950BE

Electrical System.....	4-57
Engine Cooling System.....	4-60
Fuel Transfer Pump (Optional).....	4-63

Long Term Storage.....	4-65
Maintenance in Special Conditions	4-66
Transportation.....	5-1
Loading and Unloading	5-1
Lifting With Sling	5-5
Troubleshooting.....	6-1
Electrical System	6-1
Engine	6-2
Hydraulic System.....	6-3
Swing System.....	6-4
Travel System	6-5
Specification	7-1
Standard Specification	7-1
Overall Dimensions.....	7-2
Working Range	7-3
Approximate Weight of Workload Materials	7-4
Index.....	8-1

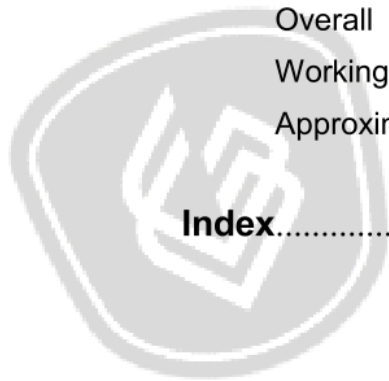

GUNTER
GROSSMANN



GÜNTER
GROSSMANN

Safety

TO THE OPERATOR OF A *Günter Grossmann* EXCAVATOR



Unsafe use of the excavator could lead to serious injury or death. Operating procedures, maintenance and equipment practices or traveling or shipping methods that do not follow the safety guidelines on the following pages could cause serious, potentially fatal injuries or extensive damage to the machine or nearby property.

Please respect the importance of taking responsibility for your own safety, and that of other people who may be affected by your actions.

The safety information on the following pages is organized into the following sections:

1. "Location of Safety Labels" on page 1-4
2. "Summary of Safety Precautions for Lifting in Digging Mode" on page 1-15
3. "Unauthorized Modifications" on page 1-16
4. "General Hazard Information" on page 1-16
5. "Before Starting Engine" on page 1-25
6. "Machine Operation" on page 1-29
7. "Maintenance" on page 1-35
8. "Battery" on page 1-44
9. "Towing" on page 1-46
10. "Shipping and Transportation" on page 1-47
11. "Excavator Rated Lift Capacity Tables" on page 1-48



WARNING

Improper operation and maintenance of this machine can be hazardous and could result in serious injury or death.

Operator and maintenance personnel should read this manual thoroughly before beginning operation or maintenance.

Keep this manual in the storage compartment to the rear of the operator's seat, and have all personnel involved in working on the machine read the manual periodically.

Some actions involved in operation and maintenance of the machine can cause a serious accident, if they are not done in a manner described in this manual.

The procedures and precautions given in this manual apply only to intended uses of the machine.

If you use your machine for any unintended uses that are not specifically prohibited, you must be sure that it is safe for any others. In no event should you or others engage in prohibited uses or actions as described in this manual.

Günter Grossmann delivers machines that comply with all applicable regulations and standards of the country to which it has been sent. If this machine has been purchased in another country or purchased from someone in another country, it may lack certain safety devices and specifications that are necessary for use in your country. If there is any question about whether your product complies with the applicable standards and regulations of your country, consult Günter Grossmann or your Günter Grossmann distributor before operating the machine.



SAFETY ALERT SYMBOL



Be Prepared - Get to Know All Operating and Safety Instructions.

This is the Safety Alert Symbol. Wherever it appears in this manual or on safety signs on the machine you should be alert to the potential for personal injury or accidents. Always observe safety precautions and follow recommended procedures.

Learn Signal Words Used with Safety Alert Symbol

The words "CAUTION" "WARNING" and "DANGER" used throughout this manual and on decals on the machine indicate degree of risk of hazards or unsafe practices. All three degrees of risk indicate that safety is involved. Observe precautions indicated whenever you see the Safety Alert "Triangle" no matter which signal word appears next to the "Exclamation Point" symbol.

CAUTION

This word is used on safety messages and safety labels and indicates potential threat of a hazardous situation that, if not avoided, could result in minor or moderate injury. It may also be used to alert against a generally unsafe practice.

WARNING

This word is used on safety messages and safety labels and indicates potential threat of a hazardous situation that, if not avoided, could result in serious injury or death. It may also be used to alert against highly unsafe practice.

DANGER

This word is used on safety messages and safety labels and indicates an imminent hazard of a situation that, if not avoided, is very likely to cause death or extremely serious injury. It may also be used to alert against equipment that may detonate or explode if handled or treated carelessly.

Safety precautions are described in SAFETY from page 1-4 on.

Günter Grossmann cannot predict every circumstance that might involve a potential hazard in operation and maintenance. Therefore the safety messages in this manual and on the machine may not include all possible safety precautions. If any procedures or actions not specifically recommended or allowed in this manual are used, you must be sure that you and others can do such procedures and actions safely and without damaging the machine.

LOCATION OF SAFETY LABELS

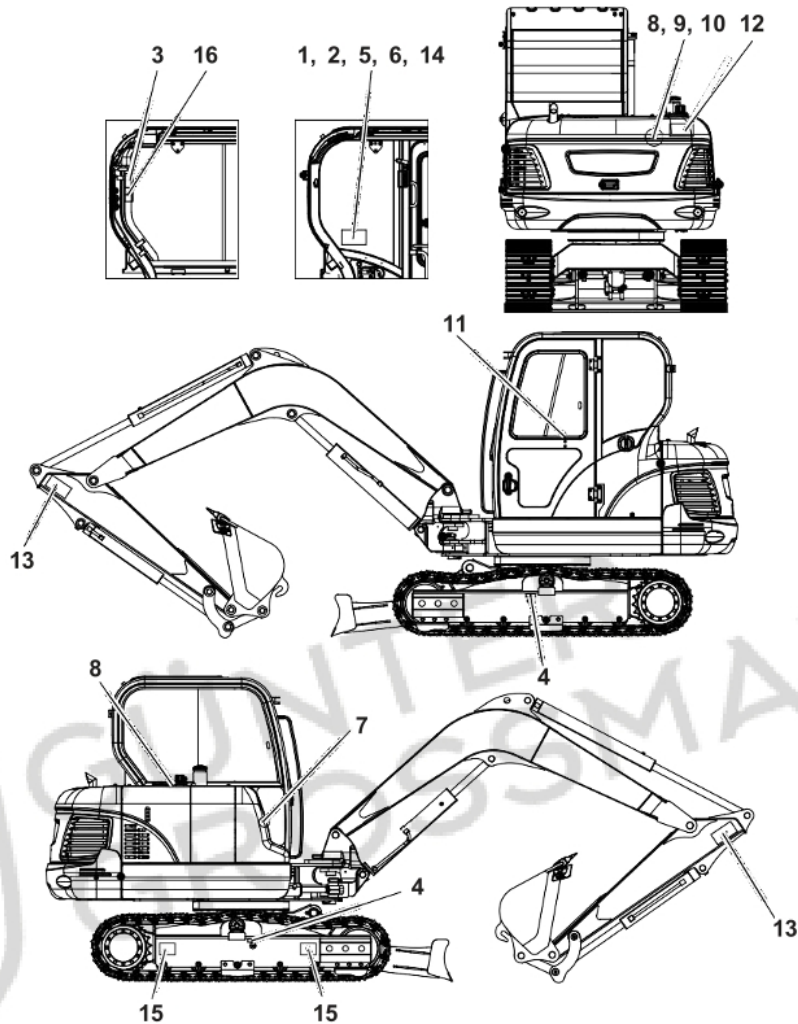

Figure 1

FG015712









There are several specific warning signs on this machine. The exact location of hazards and the description of the hazards are reviewed in this section.

Please become familiarized with all warning signs.

Make sure that all the warning signs are legible. Clean the warning signs or replace the warning signs if you cannot read the words. Replace the illustrations if the illustrations are not visible. When you clean the warning signs, use a cloth, water and soap. Do not use solvent, gasoline, or other harsh chemicals to clean the safety signs. Solvents, gasoline, or other harsh chemicals could loosen the adhesive that secures the warning sign. Loose adhesive will allow the warning sign to fall off.

Replace any safety sign that is damaged, or missing. If a safety sign is attached to a part that is replaced, install a safety sign on the replacement part.

1. Warnings for Operation, Inspection and Maintenance (950205-01466, 190-00092)

 WARNING	 DANGER								
AVOID INJURY OR DEATH	 <p>ELECTROCUTION WILL CAUSE SERIOUS INJURY OR DEATH Keep machine and attachment a safe distance from electrical power lines.</p> <table border="1"> <thead> <tr> <th>Line voltage</th> <th>Safe Distance</th> </tr> </thead> <tbody> <tr> <td>6.6 kv</td> <td>At least 3m(10ft)</td> </tr> <tr> <td>66.0 kv</td> <td>At least 5m(16ft)</td> </tr> <tr> <td>275.0 kv</td> <td>At least 10m(33ft)</td> </tr> </tbody> </table>	Line voltage	Safe Distance	6.6 kv	At least 3m(10ft)	66.0 kv	At least 5m(16ft)	275.0 kv	At least 10m(33ft)
Line voltage		Safe Distance							
6.6 kv	At least 3m(10ft)								
66.0 kv	At least 5m(16ft)								
275.0 kv	At least 10m(33ft)								
<p> Never use the Excavator without instructions. Read Operation & Maintenance Manual before operating.</p> <p> Sound the horn to alert bystanders before operating. Keep bystanders away from work area.</p> <p> Never work under raised machine if supported only by boom and arm.</p>	IMPORTANT								
<p>TO LEAVE THE EXCAVATOR :</p> <ol style="list-style-type: none">  Lower the attachment to the ground and make sure all controls are in neutral.  Lower safety lever to LOCK position.  Stop the engine and remove the key. 	<p>Electrical welding on the frame can damage the engine's Electronic Control Unit (ECU).</p> <p>Read and follow the instructions in the Operation & Maintenance Manual before welding</p>								
950205-01466									

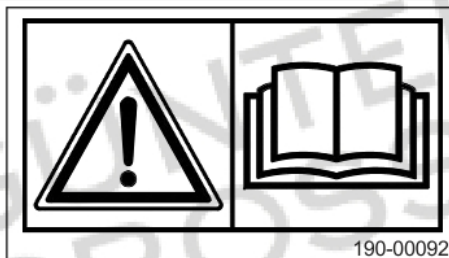

FG017941

2. Warnings for High Voltage (190-00096)

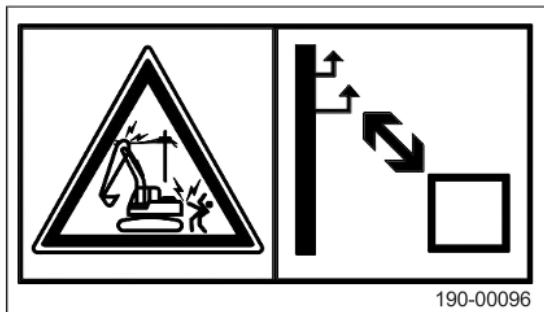

FG017942

3. Warnings When Opening a Front Window (950205-01460)



FG017943

4. Warnings for a High-pressure Cylinder (950205-01463)

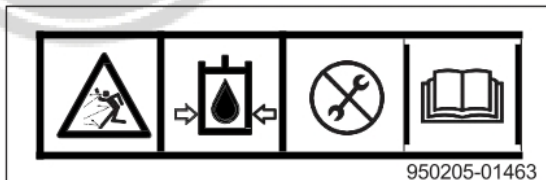

FG017944

5. Warnings When Adjusting Track Tension (190-00521)

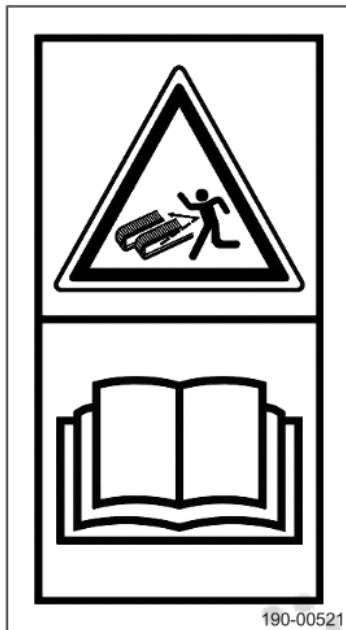

FG017945

6. Warnings for Leaving Operator's Seat (190-00094)

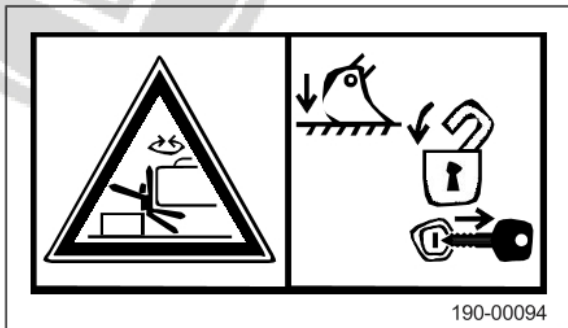

FG017946

7. Warnings for Batteries Maintenance (950205-01448, 190-00100)

⚠ DANGER



BATTERY EXPLOSION OR CONTACT WITH BATTERY ACID WILL CAUSE SERIOUS INJURY OR DEATH

- Keep arcs, sparks, flames and lighted tobacco away.
- DO NOT store metal tools or flammable materials on or around batteries.
- Wear safety glasses and rubber gloves when working with batteries.
- If battery acid contact occurs:
 1. Flush your skin with water immediately and apply baking soda or lime to neutralize the acid.
 2. Flush your eyes with water for 10-15 minutes.
 3. Get medical attention immediately.

950205-01448



FG017947

8. Warnings for High Temperature Hydraulic Oil (950205-01450, 190-00097)

⚠ WARNING



HOT PRESSURIZED OIL CAN CAUSE SERIOUS INJURY OR DEATH

Before opening cap:

1. Turn engine off.
2. Allow oil to cool.
3. Turn breather cap slowly to relieve tank pressure.

950205-01450



FG017948

**9. Warnings for Hot Coolant
(950205-01453, 190-00097)**

	<p>▲ WARNING</p> <p>HOT PRESSURIZED FLUID HAZARD</p> <ul style="list-style-type: none"> • Do not loosen or open radiator cap when engine is hot. • Before opening cap, stop engine and allow engine to cool. Loosen cap slowly.
	<p>950205-01453</p>

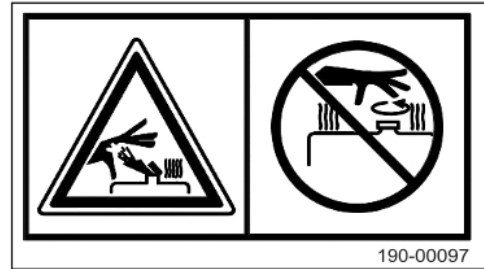

FG017949

**10. Warnings for Rotating Parts
(950205-01467, 190-00095, 190-00557)**

<p>▲ WARNING</p>	
	
<p>Rotating parts can cause serious injury or death Stop engine before servicing</p>	
<p>950205-01467</p>	

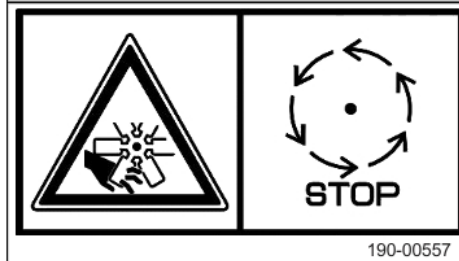
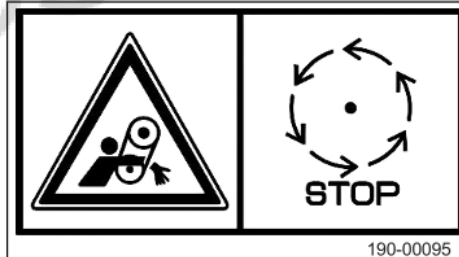

FG017951

11. Warning Tag - Used When Inspection and Maintenance
(950205-01451, 190-00098A)

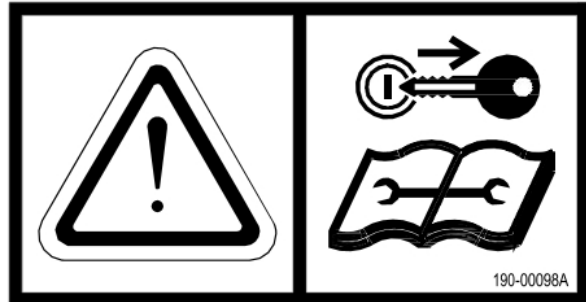

FG017952

12. Keep Out of Swing Area
(950205-01476, 190-00163)

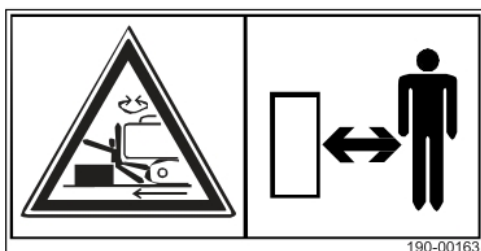

FG017974

13. Warning for Front Attachments (950205-01475)



FG017967

14. Warning for Engine ECU (950205-01452)

IMPORTANT

Electrical welding on the frame can damage the engine's Electronic Control Unit .

Read and follow the instructions in the Operation & Maintenance Manual before welding.

950205-01452

FG017955

15. Warning for Lifting, Tie Down (K1042074A)

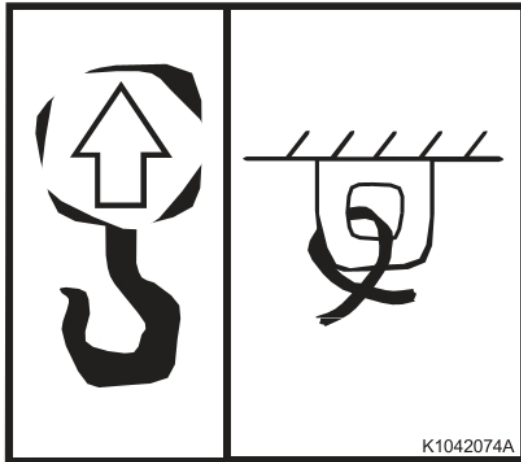

FG014828

16. Warnings for Visibility (950205-00862A, 950205-00863)



FG017956

VISIBILITY INFORMATION

A rear view camera and mirrors ensure that visibility around the machine, from the operator's seat, meets the latest ISO standards for the region or marketplace that machine is sold into.

NOTE: *These devices may vary from one region to another, depending upon local and regional regulations. If a machine is moved or sold into another region or marketplace, it is the owner's responsibility to make sure it complies with all regulations.*

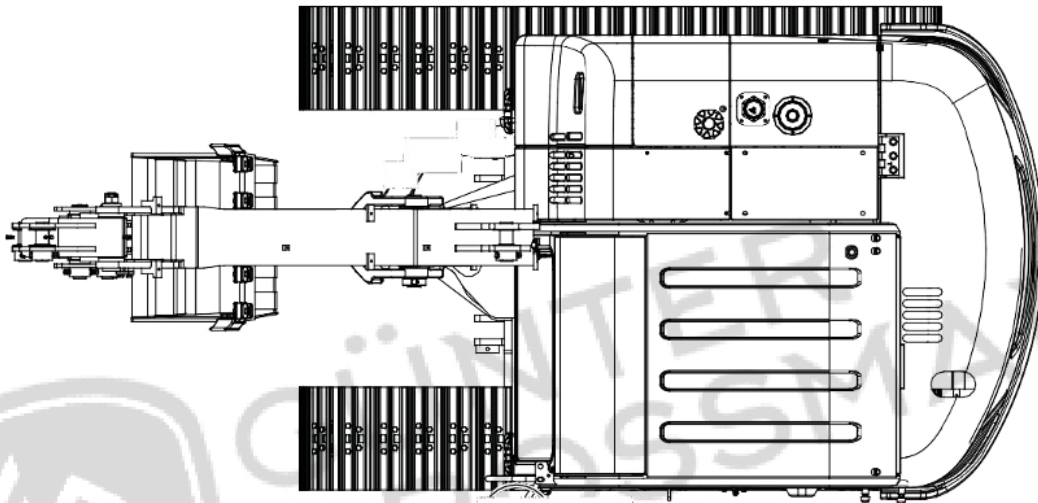

FG015711

Figure 2



WARNING

Failure to check for and clear people from the surrounding area of a machine could result in serious injury or death. The operator should make sure that visual aids (mirrors and camera (s)) are in proper working condition. Look for any possible blind spots.

Your machine may be equipped with visual aids; mirrors or cameras, but even with these aids, there still may be blind spots which cannot be seen from the operator's seat, so always be careful when operating.

Adjust the visual aids for the best visibility criteria for all areas around the machine.

When swinging or backing up, press button to change display mode on monitor so you can check rear and side of machine. Before moving the machine, look around the work

site through mirrors and monitor to confirm that no one is around the machine.

While operating or traveling in places with poor visibility, and if it is impossible to confirm the condition of the work site, or if an obstacle is in the area around the machine, there can be a danger that machine may suffer damage or operator or others may suffer serious personal injury.

Inspect equipment and immediately report if there are problems with the visual aids. If machine cannot be fixed immediately, DO NOT use the machine. Contact your local Günter Grossmann distributor as soon as possible and ask for repairs.

Guidelines

- If the visibility cannot be sufficiently assured, use a flagman. The operator should pay careful attention to the signals and follow the instructions of the flagman.
- Signals should only be given by one flagman.
- When working in dark places, turn "ON" work lights and front lights on the machine. Set up additional lighting in the area.
- Stop operations if there is poor visibility, such as fog, snow, rain, or sandstorms.
- Check mirrors and rear view camera (optional) lens on machine before starting operations. Clean off any dirt and adjust view to ensure good visibility.

When operating or traveling during poor visibility conditions, and especially in a large machine, strictly adhere to the above guidelines.

It may not be possible to adjust all visual aids to see all the way around the machine. Therefore, additional precautions must be taken to ensure the safe operation of the machine.

NOTE: *Larger machines are more likely to have blind spots.*

NOTE: *Refer to ISO 5006 for weight class information.*

SUMMARY OF SAFETY PRECAUTIONS FOR LIFTING IN DIGGING MODE

DANGER

Unsafe use of the excavator while making rated lifts could cause serious, potentially fatal injuries or extensive damage to the machine or nearby property. Do not let anyone operate the machine unless they've been properly trained and understand the information in the Operation and Maintenance Manual.

To lift safely while in Digging Mode, the following items must be evaluated by the operator and the work site crew.

- Condition of ground support.
- Excavator configuration and attachments.
- Weight, lifting height and lifting radius.
- Safe rigging of the load.
- Proper handling of the suspended load.

Tag lines on opposite sides of the load can be very helpful in keeping a suspended load secure, if they are anchored safely to control points on the ground.

WARNING

NEVER wrap a tag line around your hands or body.

NEVER rely on tag lines or make rated lifts when wind gusts are more than 48.3 km/h (30 MPH). Be prepared for any wind gust when working with loads that have a large surface area.

Always engage the "Digging Mode" control on the Instrument Panel before using the excavator for lifting work.

WARNING

If you need more information or have any questions or concerns about safe operating procedures or working the excavator correctly in a particular application or in the specific conditions of your individual operating environment, please consult your local *Günter Grossmann* representative.

UNAUTHORIZED MODIFICATIONS

Any modification made without authorization or written approval from *Günter Grossmann* can create a safety hazard, for which the machine owner will be held responsible.

For safety's sake, replace all OEM parts with the correct authorized or genuine *Günter Grossmann* part. For example, not taking the time to replace fasteners, bolts or nuts with the correct replacement parts could lead to a condition where the safety of critical assemblies are dangerously compromised.

GENERAL HAZARD INFORMATION

Safety Rules

Only trained and authorized personnel can operate and maintain the machine.

Follow all safety rules, precautions and instructions when operating or performing maintenance on the machine.

Do not operate the machine if you are not feeling well, if you are taking medication that makes you feel sleepy, if you have been drinking, or if you are suffering from emotional problems. These problems will interfere with your sense of judgment in emergencies and may cause accidents.

When working with another operator or with a person on work site traffic duty, be sure that all personnel know the nature of the work and understand all hand signals that are to be used.

Always observe strictly any other rules related to safety.

Safety Features

Be sure that all guards and covers are installed in their proper position. Have guards and covers repaired immediately if damaged.

Be sure that you understand the method of use of safety features such as safety lock lever and the seat belt, and use them properly.

Never remove any safety features. Always keep them in good operating condition.

Failure to use safety features according to the instructions in the Operation and Maintenance Manual could result in serious bodily injury.

Inside Operator's Cabin

When entering the operator's cabin, always remove all mud and oil from the soles of your shoes. If you operate the travel pedal with mud or oil stuck to your shoes, your foot may slip and this may cause a serious accident.

After using the ashtray, make sure that any matches or cigarettes are properly extinguished, and be sure to close the ashtray. If the ashtray is left open, there is a danger of fire.

Do not stick suction pads to the window glass. Suction pads act as a lens and may cause fire.

Do not leave lighters laying around the operator's cabin. If the temperature inside the operator's cabin becomes high, there is a danger that lighter may explode.

Do not use cellular telephones inside the operator's cabin when driving or operating the machine. There is a danger that this may lead to an unexpected accident.

Never bring any dangerous objects such as flammable or explosive items into the operator's cabin.

To ensure safety, do not use the radio or music headphones when operating the machine. There is a danger that this may lead to a serious accident.

When operating the machine, do not put your hands or head out of the window.

When standing up from the operator's seat, always place safety lock lever securely in the "LOCK" position. If you accidentally touch the work equipment levers when they are not locked, the machine may suddenly move and cause serious injury or damage.

When leaving the machine, completely lower the work equipment to the ground, set safety lock lever to the "LOCK" position and shut down engine. Use the key to lock all the equipment. Always remove key and take it with you.

Clothing and Personal Protective Items

Secure long hair, and avoid loose clothing and jewelry. These items have the tendency to catch on controls or protrude into parts and cause serious injury or death.

Do not wear oily clothes. They are flammable.

Full eye protection, a hard hat, safety shoes and gloves may be required at the work site.

While working on the machine, never use inadequate tools. They could break or slip, causing injury, or they may not adequately perform intended functions.



Figure 3

Breathing Masks, Ear Protection May Be Required

Do not forget that some risks to your health may not be immediately apparent. Exhaust gases and noise pollution may not be visible, but these hazards can cause disabling or permanent injuries.

NOTE: *The equivalent continuous A-weighted sound pressure level at the workstation for this machine is 79 dB (A).*

Measurement is obtained on a dynamic machine following the procedures and cabin conditions as described in ISO 6396.

NOTE: *The guaranteed sound power level emitted by the machinery for this machine is 98 dB (A).*

Vibration Level Information

Hands/Arms: The weighted root mean square acceleration to which the hands/arms are subjected, is less than 2.5 m/s^2 .

Whole body: The weighted root mean square acceleration to which the whole body is subjected, is less than 0.5 m/s^2 .



GUNTER
GROSSMANN

Recommendations for Limiting Vibrations

1. Select the right machine, equipment and attachments for a particular application.
2. Replace any damaged seat by a *Günter Grossmann* genuinepart. Keep the seat maintained and adjusted.
 - Adjust the seat and suspension for the weight and size of the operator.
 - Inspect and maintain the suspension and adjustment mechanisms of the seat regularly.
3. Check that machine is properly maintained.
 - Tire pressure, brakes, steering, linkages, etc.
4. Steer, brake, accelerate, shift gears, move the attachments and load the attachments smoothly.
5. Adjust the machine speed and travel path to reduce the vibration level.
 - Slow down if it is necessary when traveling through rough terrain.
 - When driving machine, avoid obstacles and excessive rough terrain.
6. Keep the machine on terrain where working and traveling conditions are good.
 - Remove any large rocks or obstacles.
 - Fill any ditches and holes.
 - Provide machines for and schedule time to maintain good terrain conditions.
7. Travel over longer distances (e.g. on public roads) at adjusted (medium) speed.
 - Always adjust the speed to prevent bouncing.

Before getting on or off the machine, if there is any oil, grease, or mud on the handrails, steps, or track shoes, wipe it off immediately. Always keep these parts clean. Repair any damage and tighten any loose bolts.

Never jump on or off the machine. In particular, never get on or off a moving machine. These actions may lead to serious injury.

Never hold any control levers when getting on or off the machine.

Apply the door lock securely. If you grip the handrail inside the door when moving on top of the track shoes, and the door lock is not applied securely, the door may move and cause you to fall.

Use the points marked by arrows in the diagram when getting on or off the machine.

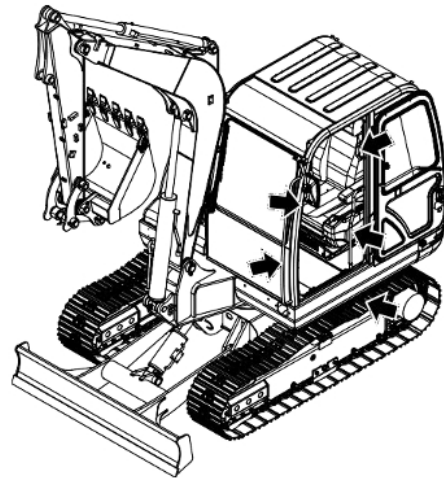

Figure 4

FG010051

Fuel, Oil and Hydraulic Fluid Fire Hazards

Fuel, oil and antifreeze will catch fire if it is brought close to a flame. Fuel is particularly flammable and can be hazardous.

Always strictly observe the following.

Add fuel, oil, antifreeze and hydraulic fluid to the machine only in a well ventilated area. The machine must be parked with controls, lights and switches turned "OFF." The engine must be "OFF" and any flames, glowing embers, auxiliary heating units or spark causing equipment must be extinguished, turned "OFF" and/or kept well clear of the machine.

Static electricity can produce dangerous sparks at the fuel filling nozzle. In very cold, dry weather or other conditions that could produce a static discharge, keep the tip of the fuel nozzle in constant contact with the neck of the fuel filling nozzle, to provide a ground.

Keep fuel and other fluid reservoir caps tight and do not start the engine until caps have been secured.



Figure 5

ARO1050S

Precautions When Handling Fluids at High Temperature

Immediately after operations are stopped, the coolant, engine oil, and hydraulic oil are at highest temperatures and the radiator and hydraulic tank are still under pressure. Attempting to remove cap, drain the oil or coolant, or replacing the filters may lead to serious burns. Always wait for the temperature to go down, and follow the specified procedures when carrying out these operations.

To prevent hot coolant from spurting out, shut down engine, wait for the coolant to cool, then loosen the cap slowly to relieve the pressure.

To prevent hot oil from spurting out, shut down engine, wait for the oil to cool, then loosen the cap slowly to relieve the pressure.



HAOA050L

Figure 6



HAOA060L

Figure 7

Asbestos Dust Hazard Prevention

Asbestos dust can be HAZARDOUS to your health if it is inhaled. Materials containing asbestos fiber can be present on work site. Breathing air that contains asbestos fiber can ultimately cause serious or fatal lung damage. To prevent lung damage from asbestos fiber, observe following precautions:

- Use a respirator that is approved for use in an asbestos-laden atmosphere.
- Never use compressed air for cleaning.
- Use water for cleaning to keep down the dust.
- Work on the machine or component with the wind at your back whenever possible.
- Always observe any regulations related to the work site and working environment.

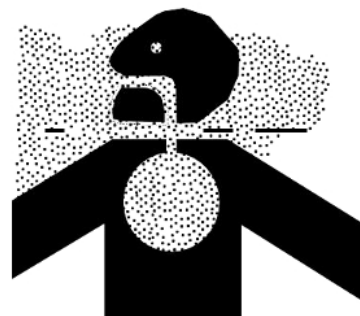

ARO1770L

Figure 8

Injury from Work Equipment

Do not enter or put your hand, arm or any other part of your body between movable parts, such as between the work equipment and cylinders, or between the machine and work equipment.

If the control levers are operated, the clearance between the machine and the work equipment will change and this may lead to serious damage or personal injury.

If going between movable parts is necessary, always position and secure the work equipment so it cannot move.



HDO1010L

Figure 9

Fire Extinguisher and First Aid Kit

As a precaution if any injury or fire should occur, always do the following.

- Be sure that fire extinguishers have been provided and read the labels to ensure that you know how to use them. It is recommended that an appropriately sized (2.27 kg [5 lb] or larger) multipurpose "A/B/C" fire extinguisher be mounted in the cabin. Check and service the fire extinguisher at regular intervals and make sure that all work site crew members are adequately trained in its use.
- Provide a first aid kit in the storage compartment and keep another at the work site. Check the kit periodically and make any additions if necessary.
- Know what to do in case of injury from fire.
- Keep emergency numbers for doctor, ambulance service, hospital and fire department near your telephone.

If the machine catches fire, it may lead to serious personal injury or death. If a fire occurs during operation, escape from the machine as follows:

- Turn the starter switch to the "O" (OFF) position and shut down engine.
- If there is time, use the fire extinguisher to put out as much of the fire as possible.
- Use the handrails and steps to escape from the machine.

The above is the basic method for escaping from the machine, but changing the method may be necessary according to the conditions, so carry out practice drills at the work site.



HDO1009L

Figure 10

Protection from Falling or Flying Objects

On work sites where there is a danger that falling or flying objects may hit the operator's cabin select a guard to match the operating conditions to protect the operator.

Working in mines, tunnels, deep pits or on loose or wet surfaces could produce danger of falling rock or hazardous flying objects. Additional protection for the operator's cabin could be required in the form of a FOPS (Falling Object Protective Structure) or window guards.



HAOA110L

Figure 11

Never attempt to alter or modify any protective structure reinforcement system, by drilling holes, welding, remounting or relocating fasteners. Any serious impact or damage to the system requires a complete integrity reevaluation. Reinstallation, recertification and/or replacement of the system may be necessary.

Contact your *Günter Grossmann* distributor for available safety guards and/or recommendations to prevent danger of getting hit by objects that could strike the operator's cabin. Make sure that all other work site crew members are kept well away from the excavator and safe from possible hazards.

For breaker operation, install a front guard and apply a laminated coating sheet to the front glass. Contact your *Günter Grossmann* distributor for recommendations.

When carrying out demolition or cutting operation, install a front guard and top guard, and apply a laminated coating sheet to the front glass.

When working in mines or quarries where there is a danger of falling rock, install FOPS (Falling Objects Protective Structure) and apply a laminated coating sheet to the front glass.

If any glass on the machine is broken, replace it with new glass immediately.



HAOA100L

Figure 12

Attachment Precautions

Option kits are available through your dealer. Contact *Günter Grossmann* for information on available one-way (single-acting) and two-way (double-acting) piping / valving / auxiliary control kits. Because *Günter Grossmann* cannot anticipate, identify or test all the attachments that owners may wish to install on their machines, please contact *Günter Grossmann* for authorization and approval of attachments, and their compatibility with optional kits.

Indoor Ventilation

Engine exhaust gases can cause fatal accidents, and unconsciousness, loss of alertness, judgment and motor control and serious injury.

Make sure there is adequate ventilation before starting the engine in any enclosed area.

You should also be aware of open windows, doors or ductwork where exhaust may be carried, or blown by the wind, exposing others to danger.

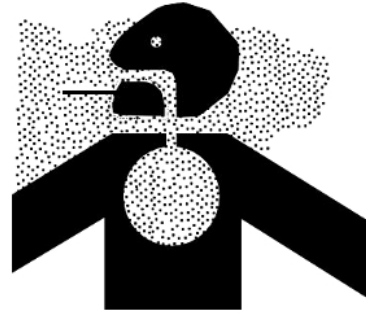

ARO1770L

Figure 13

Emergency Exit

This machine is equipped with a glass breaking tool. It is at the upper left side of the operator's seat. This tool can be used in case of an emergency that requires the breaking of glass to exit from the operator's cabin. Grip the handle firmly and use the sharp point to break the glass.



WARNING

Protect your eyes when breaking the glass.

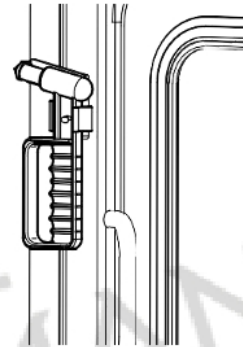

FG010052

Figure 14

BEFORE STARTING ENGINE

Work Site Precautions

Before starting operations, thoroughly check the area for any unusual conditions that could be dangerous.

Check the terrain and condition of the ground at the work site, and determine the best and safest method of operation.

Make sure the ground surface is as hard and horizontal as possible before carrying out operations. If there is a lot of dust and sand on the work site, spray water before starting operations.

If you need to operate on a street, protect pedestrians and cars by designating a person for work site traffic duty or by erecting fences and posting "No Entry" signs around the work site.

Erect fences, post "No Entry" signs, and take other steps to prevent people from coming close to or entering the work site. If people come close to a moving machine, they may be hit or caught by the machine, and this may lead to serious personal injury or death.

Waterlines, gas lines, phone lines and high-voltage electrical lines may be buried under the work site. Contact each utility and identify their locations. Be careful not to damage or cut any of these lines.

Check the condition of the riverbed, and the depth and flow of the water before operating in water or crossing a river. NEVER work in water that is more than the permissible water depth.

Any object in vicinity of boom could represent a potential hazard, or cause the operator to react suddenly and cause an accident. Use a spotter or signal person when working near bridges, phone lines, work site scaffolds, or other obstructions.

Minimum levels of insurance coverage, work permits or certification, physical barriers around the work site or restricted hours of operation may be mandated by governing authorities. There may also be regulations, guidelines, standards or restrictions on equipment that may have to be followed for local requirements. There may also be regulations related to performing certain kinds of work. If there is any question about whether your machine and work site complies with the applicable standards and regulations, contact your local authorities and agencies.

Avoid entering soft ground. It will be difficult for the machine to escape.

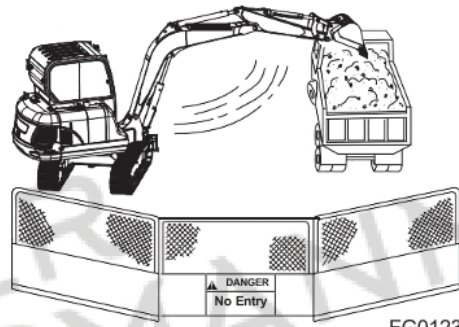

FG012355

Figure 15

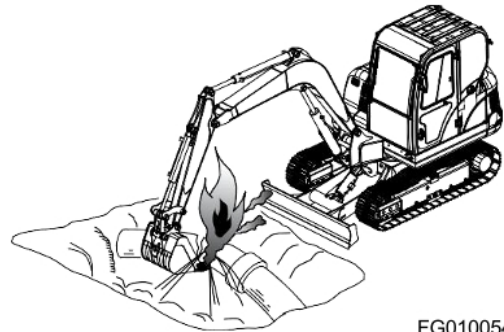

FG010054

Figure 16

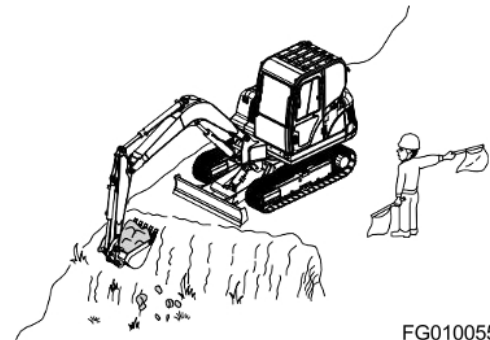

FG010055

Figure 17

Avoid operating your machine too close to the edge of cliffs, overhangs, and deep ditches. The ground may be weak in such areas. If the ground collapses, the machine could fall or tip over resulting in serious injury or death.

Remember that soil after heavy rain, blasting or after earthquakes, is weakened.

Newly laid earth and the soil near ditches is typically loose. It can collapse under the weight of vibration of your machine and cause your machine to tip over.

Install the head guard (FOPS) if working in areas where there is a danger of falling rocks.

Checks Before Starting Engine

Every day before starting the engine for the first time, carry out the following checks. If these checks are not carried out properly, there is a danger of serious injury.

Remove all wood chips, leaves, grass, paper and other flammable materials accumulated in the engine compartment and around the battery. They could cause a fire. Remove any dirt from the window glass, mirrors, handrails, and steps.

Do not leave tools or spare parts laying around in the operator's cabin. The vibration of the machine when traveling or during operations may cause them to fall and damage or break the control levers or switches. They may also get caught in the gap of the control levers and cause the work equipment to malfunction or move dangerously. This may lead to unexpected accidents.

Check the coolant, fuel, and hydraulic tank oil levels, and check for clogged air cleaner and damage to the electrical wiring.

Adjust the operator's seat to a position where it is easy to operate the machine, and check the seat belt and mounts for damage and wear.

Check the operation of the gauges and the angle of the mirrors, and check that safety lever is in "LOCKED" position.

If any abnormalities are found in the above checks, carry out repairs immediately.

Engine Starting

Walk around your machine before getting in the operator's cabin. Look for evidence of leaking fluid, loose fasteners, misaligned assemblies or any other indications of possible equipment hazard.

All equipment covers and machinery safety guards must be in place, to protect against injury while the machine is being operated.

Look around the work site area for potential hazards, people or property that could be at risk while operation is in progress.

NEVER start the engine if there is any indication that maintenance or service work is in progress, or if a warning tag is attached to controls in the cabin.

A machine that has not been used recently, or is being operated in extremely cold temperatures, could require a warm-up or maintenance service before start-up.

Check gauges and monitor displays for normal operation before starting the engine. Listen for unusual noises and remain alert for other potentially hazardous conditions at the start of the work cycle.

Do not short-circuit the starting motor to start the engine. This is not only dangerous, but may also damage the machine.

When starting the engine, sound the horn as an alert.

Start and operate the machine only while seated.



GÜNTER
GROSSMANN

Before Operating Machine

If checks are not carried out properly after starting the engine, it may result in a delay in discovering abnormalities in the machine, and this may lead to personal injury or damage to the machine.

Carry out the checks in an open area where there are no obstructions. Do not let anyone near the machine when carrying out the checks.

- Check the operating condition of the equipment, and the movement of the bucket, arm, boom, travel, and swing systems.
- Check the machine for any abnormal noise, vibration, heat, smell, or abnormality with the gauges. Check also for leakage of air, oil, and fuel.
- If any abnormality is found, repair the problem immediately. If the machine is used without repairing the problems, it may lead to unexpected injury or failure.
- Clear all personnel from directly around machine and from the area.
- Clear all obstacles from the machine's path. Beware of hazards.
- Be sure that all windows are clean. Secure the doors and the windows in the open position or in the shut position.
- Adjust the rearview mirrors for best visibility close to the machine. Make sure that horn, the travel alarm (if equipped), and all other warning devices are working properly.
- Fasten the seat belt securely.
- Warm up the engine and hydraulic oil before operating machine.
- Before moving the machine, check undercarriage position. The normal travel position is with idler wheels to the front under the cabin and the drive sprockets to the rear. When the undercarriage is in the reversed position, the travel controls must be operated in opposite directions.

MACHINE OPERATION

When Swinging or Changing Direction of Travel

Before operating the machine or the work equipment, always observe the following precautions to prevent serious injury or death.

- Start and operate the machine only while seated.
- When changing travel direction from forward to reverse or from reverse to forward, reduce speed early and stop the machine before changing travel direction.
- Sound the horn to warn people in the area.
- Check that there is no one in the area around the machine. There are blind spots behind the machine, so if necessary, swing the upper structure to check that there is no one behind the machine before traveling in reverse.
- When operating in areas that may be hazardous or have poor visibility, designate a person to direct work site traffic.
- Ensure that no unauthorized person can come within the turning radius or direction of travel.

Be sure to observe the above precautions even if a travel alarm or mirrors are installed.

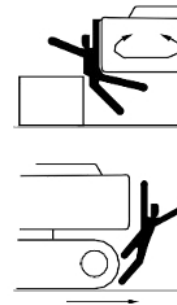

Figure 18

HAOA190L

Travel Precautions

Never turn the starting switch to the "O" (OFF) position when traveling. It is dangerous if the engine stops while the machine is traveling. It will be impossible to operate the steering.

Attachment control levers should not be operated while traveling.

Do not change selected travel mode (FAST/SLOW) while traveling.

Fold in work equipment so the outer end of the boom is as close to the machine as possible, and is 40 - 50 cm (16 - 20 in) aboveground.

Never travel over obstacles or slopes that will cause the machine to tilt severely. Travel around any slope or obstacle that causes the machine to tilt 10 degrees or more to the right or left, or 30 degrees or more from front to rear.

Do not operate the steering suddenly. The work equipment may hit the ground and cause the machine to lose its

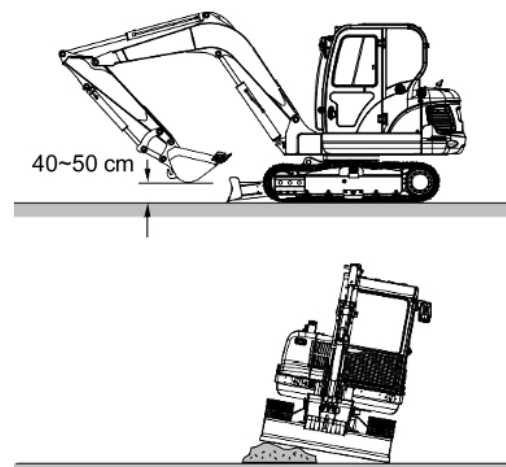

Figure 19

FG010057

balance, and this may damage the machine or structures in the area.

When traveling on rough ground, travel at low speed, and avoid sudden changes in direction.

Always keep to the permissible water depth. Permissible water depth is to the centerline of the upper track rollers.

When traveling over bridges or structures on private land, check first that bridge or structure can withstand the weight of the machine. When traveling on public roads, check with the local authorities and follow their instructions.

Traveling on Slopes

Never jump onto a machine that is running away to stop it. There is a danger of serious injury.

Traveling on slopes could result in the machine tipping over or slipping.

On hills, banks or slopes, carry the bucket approximately 20 - 30 cm (8 - 12 in) above the ground. In case of an emergency, quickly lower the bucket to the ground to help stop the machine.

Do not travel on grass, fallen leaves, or wet steel plates. Even slight slopes may cause the machine to slip to the side, so travel at low speed and make sure that machine is always traveling directly up or down the slope.

Avoid changing travel direction on a slope. This could result in tipping or sideslipping of the machine.

When possible, operate the machine up slopes and downslopes. Avoid operating the machine across the slope, when possible.

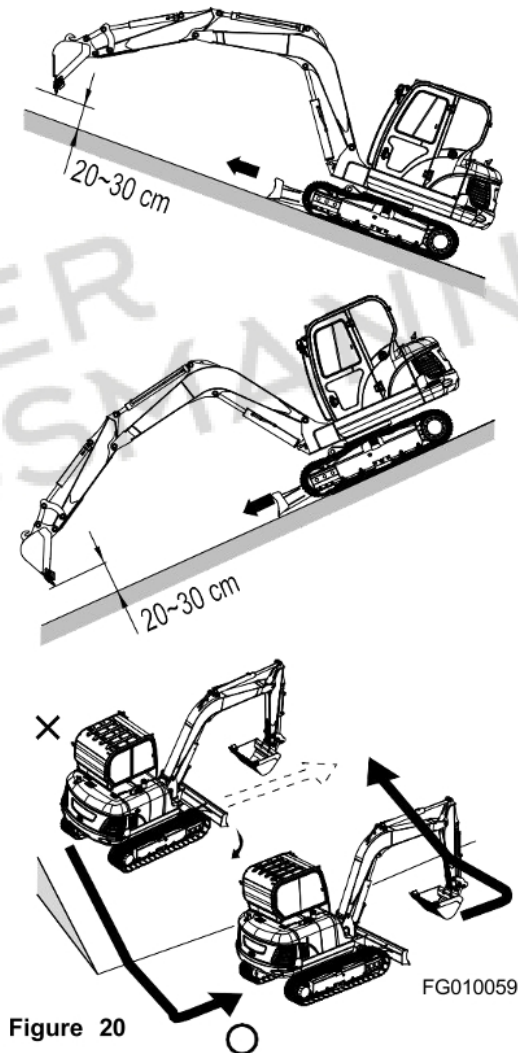

Prohibited Operations

Do not dig the work face under an overhang. This may cause the overhang to collapse and fall on top of the machine.

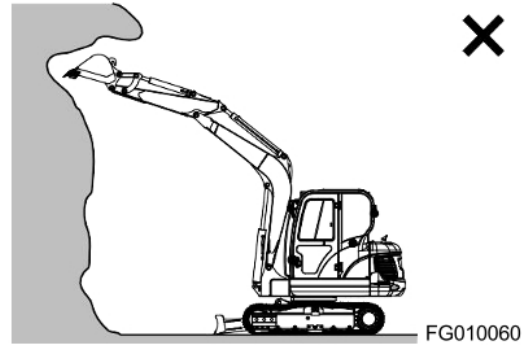

Figure 21

Do not carry out deep digging under the front of the machine. The ground under the machine may collapse and cause the machine to fall.

Working heavy loads over loose, soft ground or uneven, broken terrain can cause dangerous side load conditions and possible tip over and injury. Travel without a load or a balanced load may also be hazardous.

Never rely on lift jacks or other inadequate supports when work is being done. Block tracks fore and aft to prevent any movement.

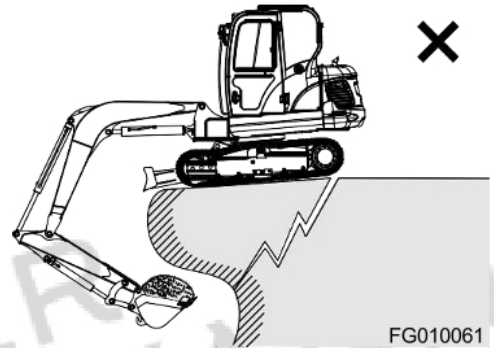

Figure 22

When using the machine, to prevent accidents caused by damage to the work equipment and overturning because of an excessive load, do not use the machine in excess of its ability (in terms of the maximum load and stability determined by the structure of the machine).

When working at the edge of an excavation or on a road shoulder, the machine could tip over, possibly resulting in serious injury or death. Investigate the configuration and ground conditions of the work site beforehand to prevent the machine from falling and to prevent the ground, stockpiles, or banks from collapsing.

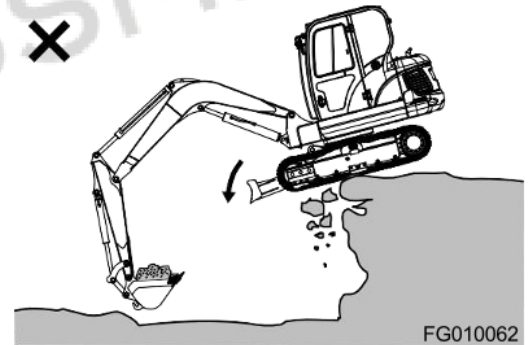

Figure 23

Precautions for Operation

Be careful not to mistakenly travel too close to the edge of a cliff.

Use the machine only for its main purpose. Using it for other purposes will cause failures.

To ensure a good view, always do the following:

- When working in dark areas, attach working lights and front lights to the machine. If necessary, set up lighting at the work site.
- Stop operations when the visibility is poor, such as in fog, mist, snow, and rain. Wait for the visibility to improve to a level which causes no problems for the operation.

To avoid hitting the work equipment, always do the following:

- When working in tunnels, on bridges, under electrical wires, or when parking the machine or carrying out other operations in places with limited height, be careful not to hit the bucket or other parts.
- To prevent collisions, operate the machine at a safe speed when working in confined spaces, indoors, or in crowded areas.
- Do not pass the bucket over the heads of workers or over the operator's cabin of dump truck.



Figure 24

Avoid High-voltage Cables

Serious injury or death can result from contact or proximity to high-voltage electrical lines. The bucket does not have to make physical contact with power lines for current to be transmitted.

Use a spotter and hand signals to stay away from power lines not clearly visible to the operator.

Voltage	Minimum Safe Distance
6.6 kV	3 m (9' 10")
33.0 kV	4 m (13' 1")
66.0 kV	5 m (16' 5")
154.0 kV	8 m (26' 3")
275.0 kV	10 m (32' 10")

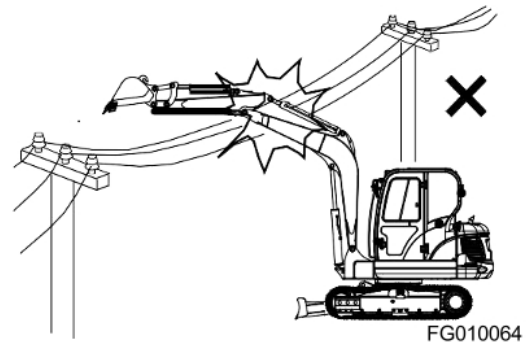

Figure 25

Use these minimum distances as a guideline only. Depending upon the voltage in the line and atmospheric conditions, strong current shocks can occur with the boom or bucket as faraway as 4 - 6 m (13 - 20 ft.) from the power line. Very high voltage and rainy weather could further decrease that safety margin.

NOTE: Before starting any operation near power lines (either aboveground or buried cable type), you should always contact the power utility company directly and work out a safety plan with them.

Operate Carefully on Snow, Ice and in Very Cold Temperatures

In icy cold weather avoid sudden travel movements and stay away from even slight slopes. The machine could skid off to one side very easily.

Snow accumulation could hide or obscure potential hazards. Use care while operating or while using the machine to clear snow.

Warming up the engine for a short period may be necessary, to avoid operating with sluggish or reduced working capacity. The jolting shocks and impact loads caused by bumping or bottoming the boom or attachment are more likely to cause severe stress in very cold temperatures. Reducing work cycle rate and workload may be necessary.

When the temperature rises, frozen road surfaces become soft, and machine travel becomes unstable.

In cold weather, do not touch metal surfaces with your bare hands. If you touch a metal surface in extremely cold weather, your skin may freeze to the metal surface.

Operations on Slopes

When working on slopes, there is a danger that machine may lose its balance and turn over, when swinging, or when work equipment is operated. Always carry out these operations carefully.

Do not swing the work equipment from the uphill side to the downhill side when the bucket is loaded. This operation is dangerous.

If the machine has to be used on a slope, pile the soil to make a platform that will keep the machine as horizontal as possible.

In addition, lower the bucket as far as possible, keep it pulled into the front, and keep the swing speed as low as possible.

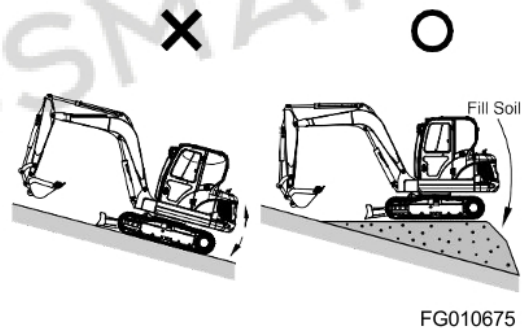

FG010675

Figure 26

Parking Machine

Avoid making sudden stops, or parking the machine wherever it happens to be at the end of the workday. Plan so the excavator will be on firm, level ground away from traffic and away from high walls, cliff edges and any area of potential water accumulation or runoff. If parking on inclines is unavoidable, block the crawler tracks to prevent movement. Lower the bucket or other working attachment completely to the ground, or to an overnight support saddle. There should be no possibility of unintended or accidental movement.

When parking on public roads, provide fences, signs, flags, or lights, and put up any other necessary signs to ensure that passing traffic can see the machine clearly. Park the machine so the machine, flags, and fences do not obstruct traffic.

After the front attachment has been lowered to an overnight storage position and all switches and operating controls are in the "OFF" position, the safety lock lever must be set to the "LOCKED" position. This will disable all pilot circuit control functions.

Always close the door of the operator's cabin.

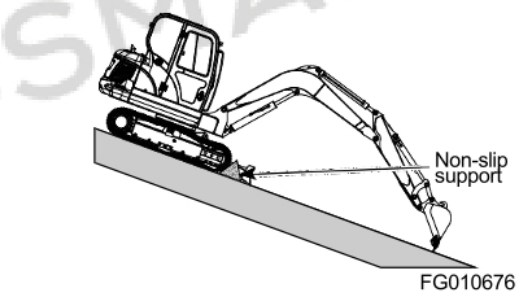
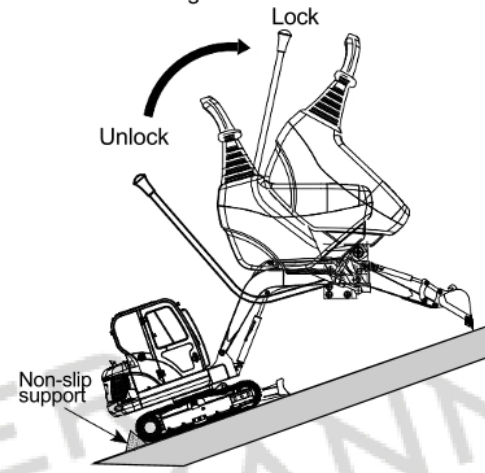
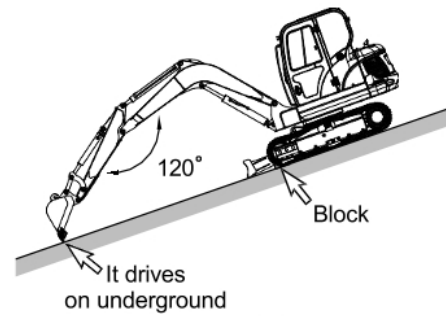

Figure 27

Never Let Anyone Ride on Attachment

Never let anyone ride on any work attachment, such as the bucket, crusher, grapple, or clamshell (grab bucket). There is a potential danger of the person falling and suffering serious injury.

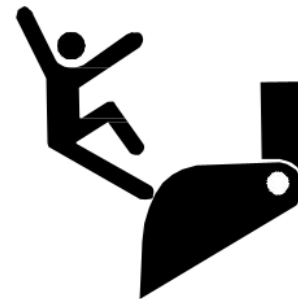

Figure 28

ARO1310L

MAINTENANCE

Warning Tag

Alert others that service or maintenance is being performed and tag operator's cabin controls – and other machine areas if required – with a warning notice. OSHA mandated control lever lockout can be made with any OSHA certified lockout device and a length of chain or cable to keep the safety lever in the fully lowered, nonactive position.

Warning tags, for controls are available from *Günter Grossmann* distributors.



FG012195

Figure 29

Clean Before Inspection or Maintenance

Clean the machine before carrying out inspection and maintenance. This prevents dirt from getting into the machine and ensures safety during maintenance.

If inspection and maintenance are carried out when the machine is dirty, it will become more difficult to locate the problems, and there is a danger that you may get dirt or mud in your eyes or that you may slip and injure yourself.

When washing the machine, do the following:

- Wear shoes with nonslip soles to prevent yourself from slipping and falling on wet places.
- Wear safety glasses and protective clothing when washing the machine with high-pressure steam.
- Take action to prevent touching high-pressure water and cutting your skin or having mud fly into your eyes.
- Do not spray water directly on electrical components (sensors, connector). If water gets into the electrical system, there is a danger that it will cause defective operation and malfunction.

Pick up any tools or hammers that are laying in the workplace, wipe up any grease or oil or any other slippery substances, and clean the area to make it possible to carry out the operation in safety. If the workplace is left untidy, you may trip or slip and suffer injury.

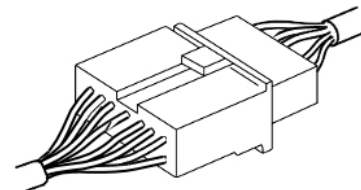
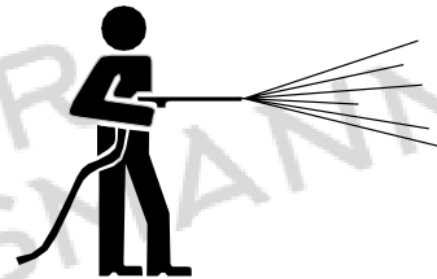

ARO1330L

Figure 30

Proper Tools

Use only tools suited to the task. Using damaged, low quality, faulty, or makeshift tools could cause personal injury. There is a danger that pieces from, chisels with crushed heads, or hammers, may get into your eyes and cause blindness.



Figure 31

HDO1037L

Use of Lighting

When checking fuel, oil, battery electrolyte, or window washing fluid, always use lighting with antiexplosion specifications. If such lighting equipment is not used, there is a danger of an explosion.

If work is carried out in dark places without using lighting, it may lead to injury, so always use proper lighting.

Even if the place is dark, never use a lighter or flame instead of lighting. There is a danger of fire. There is also danger that battery gas may catch fire and cause an explosion.



Figure 32

HDO1040L

Fire Prevention and Explosion Prevention

All fuels, most lubricants and some coolant mixtures are flammable. Leaking fuel or fuel that is spilled onto hot surfaces or onto electrical components can cause a fire.

Store all fuels and all lubricants in properly marked containers and away from all unauthorized persons.

Store oily rags and other flammable material in a protective container.

Do not smoke while you refuel the machine or while you are in a refueling area.

Do not smoke in battery charging areas or in areas that contain flammable material.

Clean all electrical connections and tighten all electrical connections. Check the electrical wires daily for wires that are loose or frayed. Tighten all loose electrical wires before you operate the machine. Repair all frayed electrical wires before you operate the machine.

Remove all flammable materials before they accumulate on the machine.

Do not weld on pipes or on tubes that contain flammable fluids. Do not flame cut on pipes or on tubes that contain flammable fluids. Before you weld on pipes or on tubes or before you flame cut on pipes or on tubes, clean the pipes or tubes thoroughly with a nonflammable solvent.



Figure 33

HDO1015I

Burn Prevention

When checking the radiator coolant level, shut down engine, let the engine and radiator cool down, then check the coolant recovery tank. If the coolant level in the coolant recovery tank is near the upper limit, there is enough coolant in the radiator.

Loosen the radiator cap gradually to release the internal pressure before removing the radiator cap.

If the coolant level in the coolant recovery tank is below the lower limit, add coolant.

Cooling system conditioner contains alkali. Alkali can cause personal injury. Do not allow alkali to contact the skin, the eyes, or the mouth.

Allow cooling system components to cool before you drain the cooling system.

Hot oil and hot components can cause personal injury. Do not allow hot oil or hot components to contact the skin.

Remove hydraulic tank filter plug only after the engine has been stopped. Make sure that hydraulic tank filter plug is cool before you remove it with your bare hand. Remove hydraulic tank filter plug slowly to relieve pressure.

Relieve all pressure in the hydraulic oil system, in the fuel system, or in the cooling system before you disconnect any lines, fittings, or related items.

Batteries give off flammable fumes that can explode.

Do not smoke while you are checking the battery's electrolyte levels.

Electrolyte is an acid. Electrolyte can cause personal injury. Do not allow electrolyte to contact the skin or the eyes.

Always wear protective glasses when you work on batteries.

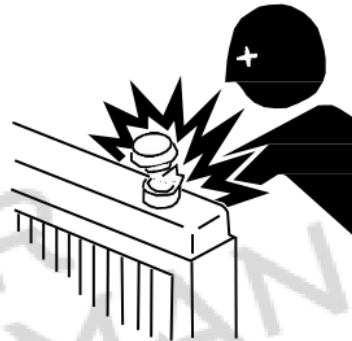
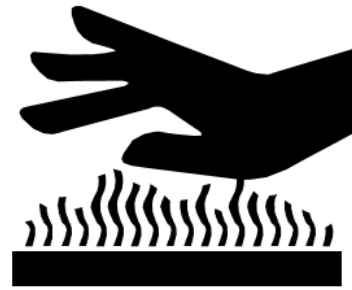

HAAE1980

Figure 34

Welding Repairs



CAUTION

When you connect or disconnect connectors between ECU and Engine or connector between ECU and the machine, always disconnect the source power to protect damage of the ECU.

If you don't observe this procedure, the ECU would be damaged or the engine would operate abnormally.

When carrying out welding repairs, carry out the welding in a properly equipped place. The welding should be performed by a qualified worker. During welding operations, there is the danger of, generation of gas, fire, or electric shock, so never let an unqualified worker do welding.

The qualified welder must do the following:

- To prevent explosion of the battery, disconnect the battery terminals and remove batteries.
- To prevent generation of gas, remove paint from the location of the weld.
- If hydraulic equipment, piping or places close to them are heated, a flammable gas or mist will be generated and there is a danger of it catching fire. To avoid this, never subject these places to heat.
- Do not weld on pipes or on tubes that contain flammable fluids. Do not flame cut on pipes or on tubes that contain flammable fluids. Before you weld on pipes or on tubes or before you flame cut on pipes or on tubes, clean the pipes or tubes thoroughly with a nonflammable solvent.
- If heat is applied directly to rubber hoses or piping under pressure, they may suddenly break, so cover them with a fireproof covering.
- Wear protective clothing.
- Make sure there is good ventilation.
- Remove all flammable objects and provide a fire extinguisher.

Preparation for Electrical Welding on Body Structure

To prevent damage to ECU by electrical welding, please observe the following procedures:

1. Open the door of the battery cover.
2. Detach the cover after loosening the bolts on the cover.
3. Detach the positive and negative terminal cables from the battery.
4. Open the hood of engine.
5. Detach the connector (1) from the ECU that is installed at the engine.
6. Proceed with welding.
7. After welding, carefully reassemble the connector.
8. Connect the battery terminal cables.
9. Reassemble the cover over the battery.
10. Close the door of the battery cover.



Figure 35

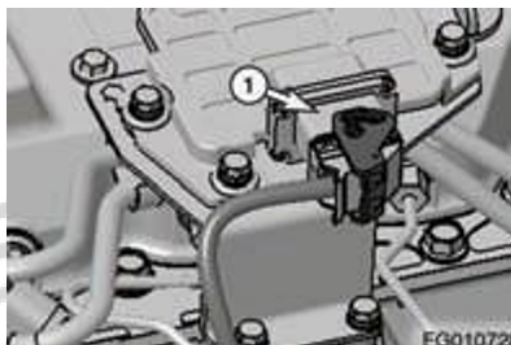

Figure 36

Warning for Counterweight and Front Attachment Removal



DANGER

Günter Grossmann warns any user, that removal of the counterweight from the machine, front attachment or any other part, may affect the stability of the machine. This could cause unexpected movement, resulting in death or serious injuries. *Günter Grossmann* is not liable for any misuse.

Never remove counterweight or front attachment unless the upper structure is in-line with the lower structure.

Never rotate the upper structure once the counterweight or front attachment has been removed.

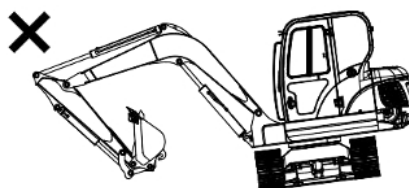

FG010276

Figure 37

Precautions for Removal, Installation, and Storage of Attachments

Before starting removal and installation of attachments, decide on the team leader.

Do not allow anyone except the authorized workers close to the machine or attachment.

Place attachments that have been removed from the machine in a safe place so they do not fall. Put up a fence around the attachments and take other measures to prevent unauthorized persons from entering.



Figure 38

HDO1041L

Precautions When Working on Machine

When carrying out maintenance operations on the machine, keep area around your feet clean and tidy to prevent falls. Always do the following:

- Do not spill oil or grease.
- Do not leave tools laying about.
- Watch your step when walking.

Never jump down from the machine. When getting on or off the machine, use the steps and handrails, and maintain a three-point contact (both feet and one hand or both hands and one foot) to support yourself securely.

If the job requires it, wear protective clothing.

To prevent injury from slipping or falling, when working on the hood or covers, never use any area except the area equipped with nonslip pads.



Figure 39

ARO1380L

Lock Inspection Covers

When carrying out maintenance with the inspection cover open, lock the cover securely in position with the lock bar.

If maintenance work is carried out with the inspection cover open but not locked, there is a danger that it may suddenly close and cause injury if there is a gust of wind.

Prevention of Crushing and Cutting

You should always have at least two people working together if the engine must be run during service. One person needs to remain in the operator's seat, ready to work the controls or stop the machine and shut off the engine.

Unless you are instructed otherwise, never attempt adjustments while the machine is moving or while the engine is running.

Stay clear of all rotating parts and moving parts.

Keep objects away from moving fan blades. The fan blades will throw objects and the fan blades can cut objects.

Do not use a wire rope cable that is kinked or frayed. Wear gloves when you handle a wire rope cable.

When you strike a retainer pin, the retainer pin might fly out. The loose retainer pin can injure personnel. Make sure that area is clear of people when you strike a retainer pin. To avoid injury to your eyes, wear protective glasses when you strike a retainer pin.

Track Tension Adjustment Requires Caution

Never turn out the track tension grease valve. To release pressure from the crawler frame track tension assembly, you should NEVER attempt to disassemble the track adjuster or attempt to remove grease fitting or valve assembly.

Keep your face and body away from the valve. Refer to the track adjustment procedure in the Operator and Maintenance Manual or Shop Manual.



Figure 40

HAAO110L

Supports and Blocks for Work Equipment

Do not allow weight or equipment loads to remain suspended.

Lower everything to the ground before leaving the operator's seat.

Do not use hollow, cracked or unsteady wobbling supports.

Do not work under any equipment supported only by a lifting jack.



Figure 41

HDO1042L

Action When Abnormality Is Found During Inspection

If any abnormality is found during inspection, always carry out repairs. In particular, if the machine is used when there are still problems with the brake or work equipment systems, it may lead to serious injury.

If necessary depending on the type of failure, please contact your *Günter Grossmann* distributor for repairs.

Precautions with High-pressure Lines, Tubes and Hoses

When inspecting or replacing high-pressure piping or hoses, check to verify that pressure has been released from the circuit. Failure to release the pressure may lead to serious injury. Always do the following:

- Wear protective glasses and leather gloves.
- Fluid leaks from hydraulic hoses or pressurized components can be difficult to see but pressurized oil has enough force to pierce the skin and cause serious injury. Always use a piece of wood or cardboard to check for suspected hydraulic leaks. Never use your hands or expose your fingers.
- Do not bend high-pressure lines. Do not strike high-pressure lines. Do not install lines, tubes or hoses that are bent or damaged.
- Make sure that all clamps, guards and heat shields are installed correctly to prevent vibration, rubbing against other parts, and excessive heat during operation.
 - If any of the following conditions are found, replace the part:
 - Damage or leakage from hose end.
 - Wear, damage, cutting of covering, or exposure of strengthening wire layer.
 - Cover portion is swollen in places.
 - There is twisting or crushing at movable parts of hose.
 - Foreign material is embedded in the covering.
 - Hose end is deformed.

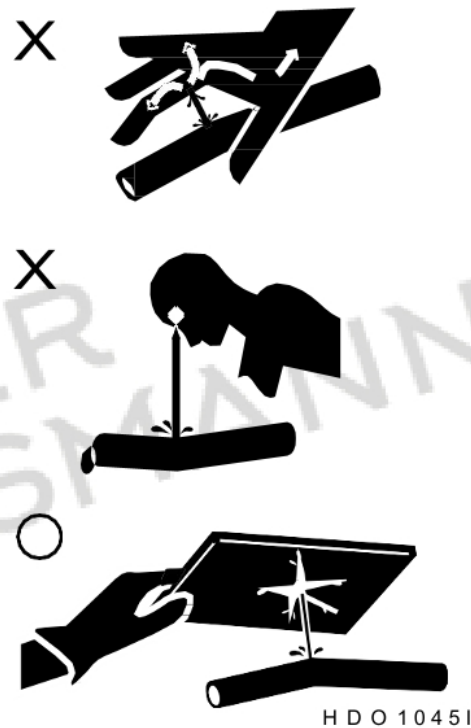

Figure 42

Waste Materials

Physical contact with used motor oil may pose a health risk. Wipe oil from your hands promptly and wash off any remaining residue.

Used motor oil is an environmental contaminant and may only be disposed of at approved collection facilities. To prevent pollution of the environment, always do the following:

- Never dump waste oil in a sewer system, rivers, etc.
- Always put oil drained from your machine in containers. Never drain oil directly onto the ground.
- Obey appropriate laws and regulations when disposing of harmful materials such as oil, fuel, solvent, filters, and batteries.

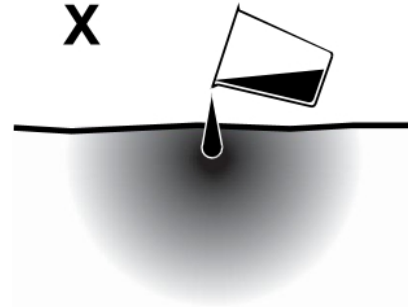

HAOA470L

Figure 43



GÜNTER
GROSSMANN

BATTERY

Battery Hazard Prevention

Battery electrolyte contains diluted sulfuric acid and batteries generate hydrogen gas. Hydrogen gas is highly explosive, and mistakes in handling can cause serious injury or fire. To prevent problems, always do the following:

- Do not smoke or bring any flame near the battery.
- When working with batteries, ALWAYS wear safety glasses and rubber gloves.
- If you spill battery electrolyte on yourself or your clothes, immediately flush the area with water.
- If battery electrolyte gets into your eyes, flush them immediately with large quantities of water and see a doctor at once.
- If you accidentally drink battery electrolyte, drink a large quantity of water or milk, raw egg or vegetable oil. Call a doctor or poison prevention center immediately.
- When cleaning the top surface of the battery, wipe it with a clean, damp cloth. Never use gasoline, thinner, or any other organic solvent or detergent.
- Tighten the battery caps securely.
- If the battery electrolyte is frozen, do not charge the battery or start the engine with power from another source. There is a danger that battery may catch fire.
- When charging the battery or starting with power from another source, let the battery electrolyte melt and check that there is no leakage of battery electrolyte before starting the operation.
- Always remove battery from the machine before charging.

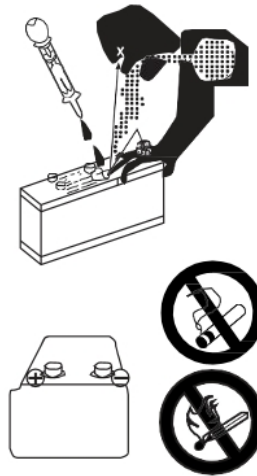

Figure 44

HAAE2100

Boost Starting or Charging Engine Batteries

If any mistake is made in the method of connecting the booster cables, it may cause an explosion or fire. Always do the following:

- Turn off all electrical equipment before connecting leads to the battery. This includes electrical switches on the battery charger or boost starting equipment.
- When boost starting from another machine or vehicle do not allow the two machines to touch. Wear safety glasses or goggles while required battery connections are made.
- 24 volt battery units consisting of two series connected twelve volt batteries have a cable connecting one positive terminal on one of the 12 volt batteries to a negative terminal on the other battery. Booster or charger cable connections must be made between the nonseries connected positive terminals and between the negative terminal of the booster battery and the metal frame of the machine being boosted or charged. Refer to the procedure and illustration in "Starting Engine With a Booster Cable" on page 3-7 of this manual.
- Connect positive cable first when installing cables and disconnect the negative cable first when removing them. The final cable connection, at the metal frame of the machine being charged or boost started, should be as faraway from the batteries as possible.

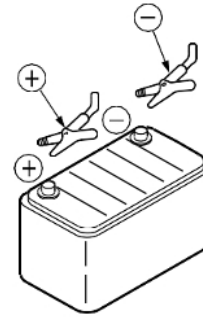

Figure 45

HAOA310L

TOWING

Precautions When Towing

If any mistake is made in the method of selecting or inspecting the towing wire or in the method of towing, it may lead to serious personal injury. Always do the following:

- Always use the method of towing given in this Operation and Maintenance Manual. Do not use any other method.
- Use leather gloves when handling the wire rope.
- When carrying out the preparation work for towing with two or more workers, determine the signals to use and follow these signals correctly.
- Always fit the towing rope to the left and right hooks and secure in position.
- If the engine on the problem machine will not start or there is a failure in the brake system, always contact your *Günter Grossmann* distributor.
- Never go between the towing machine and the towed machine during the towing operation.
- It is dangerous to carry out towing on slopes, so select a place where the slope is gradual. If there is no place where the slope is gradual, carry out operations to reduce the angle of the slope before starting the towing operation.
- When towing a problem machine, always use a wire rope with a sufficient towing capacity.
- Do not use a frayed, kinked rope or a rope with any loss of diameter.
- Do not use the lightweight towing hook for towing another machine.

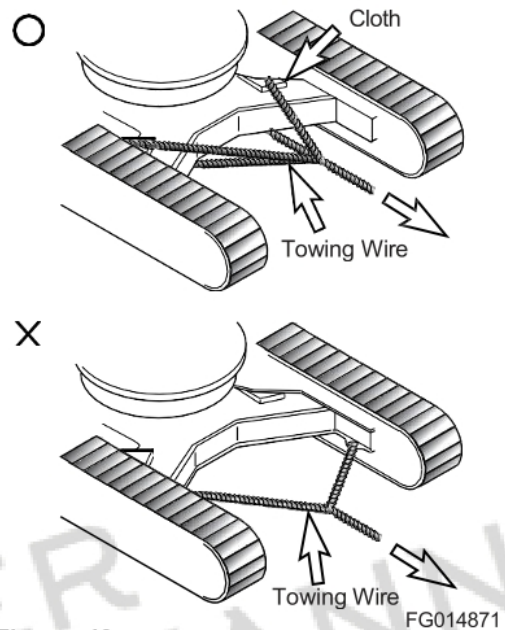

Figure 46

FG014871

SHIPPING AND TRANSPORTATION

Obey State and Local Over-the-Road Regulations

Check state and local restrictions regarding weight, width and length of a load before making any other preparation for transport.

The hauling vehicle, trailer and load must all be in compliance with local regulations governing the intended shipping route.

Partial disassembly or teardown of the excavator may be necessary to meet travel restrictions or particular conditions at the work site. See the Shop Manual for information on partial disassembly.

Refer to the Transportation and Shipping section of this Operation and Maintenance Manual for information on loading, unloading and towing.



GÜNTER
GROSSMANN

EXCAVATOR RATED LIFT CAPACITY TABLES



WARNING

Let everybody be away from the boom cylinder. While lifting operation, boom, arm, bucket hoses might burst and then high-pressure oil will be ejected at high-speed.

If that failure mode takes place, handling weight or front structure might fall by its gravity to the ground to cause fatal injury to the person.

When changing the hoses record the part numbers of the hoses to factory log book.

Do the service job under the company's serviceman.

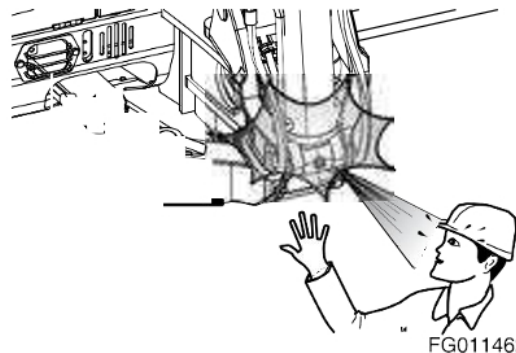

Figure 47



WARNING

All rated lift capacities are based on the machine and the load both remaining level at all times. **DO NOT EXCEED THE RATED LIFT CAPACITY.** Lifting loads greater than those shown in the rated capacity tables can cause catastrophic equipment failure and/or structural collapse of the machine.

To operate safely the excavator should be on a firm, level and uniformly supporting surface. The operator is expected to make due allowance for all specific work site and lift related conditions, and respond to changes in those conditions that could pose a hazard. The following could all cause hazardous conditions and accidents or injuries:

- Soft or uneven ground.
- Unlevel terrain.
- Side loads.
- Modifications or poor maintenance of the excavator.
- Failure to lift squarely over the end or over the side of the machine.

When a load is in the air, the operator must remain alert.

- Avoid side loads that may be caused by uneven slings, traveling with the load or swinging too quickly.
- The load can become unbalanced if the hook line is twisted and starts to rotate. If the surface area of the load is large enough, wind gusts can create side loads.
- Keep the bucket hook point directly over the load. Tag lines on opposite sides of the load can help maintain greater stability against side loads and wind gusts.

Avoid traveling with a suspended load. Before swinging (or if required, traveling), bring the load into an arm position (radius and height) that has a safer weight capacity rating and adequate movement clearance. The operator and all work site personnel should be thoroughly familiar with safety instructions and procedures within this Operation and Maintenance Manual.

The following weight loads are in compliance with SAE (J1097) and ISO applicable, recommended standards for hydraulic excavators performing lifting operation on a firm supporting surface. An asterisk (*) next to the lift rating indicates rated load does not exceed 87% of hydraulic capacity. All other ratings have been determined not to exceed 75% of tipping capacity.

Do not attempt to lift or hold any load that exceeds rated load capacity at the specified distances (from the machine's rotation centerline and height - see "lift radius" and "lift height" in the reference drawing, Figure 48).

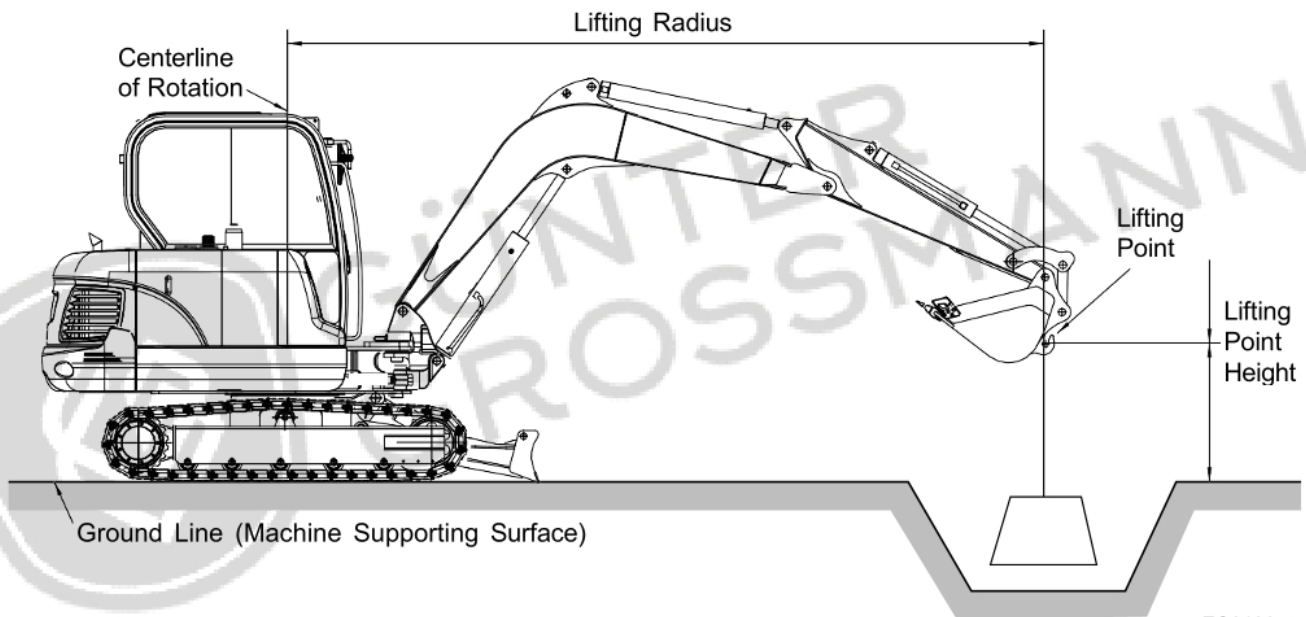

FG010677

Figure 48



The weight of slings and any auxiliary lifting device (and/or the weight difference of any attachment heavier than standard configuration) must be deducted from the rated lift capacity to determine allowable net lifting load. The lift point should be on the back of the bucket, as shown in Figure 48.

IMPORTANT



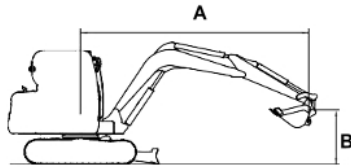







Select the Digging Mode switch on the Instrument Panel before using the excavator for lifting work. Engine and hydraulic oil should both be fully warmed up to operating temperature before starting a lift.

DOZERUP









TRACK WIDTH	: 1.88 m (6' 2") STD TRACK
BOOM	: 3 m (9' 10")
ARM	: 1.6 m (5' 3")
BUCKET	: SAE 0.175 m ³ (CECE 0.151 m ³)
SHOE	: 400 mm (16")
	: RATING OVER FRONT
	: RATING OVER SIDE OR 360 degree
UNIT	: 1,000 kg

METRIC

A(m) \ B(m)	2		3		4		5		MAX. REACH		A(m)
											
4					* 0.97	0.86			* 0.86	0.73	4.37
3					* 1.07	0.84			* 0.86	0.58	4.96
2	* 3.07	2.39	* 1.68	1.26	1.33	0.81	0.94	0.56	0.86	0.51	5.26
1			2.00	1.17	1.28	0.76	0.92	0.54	0.83	0.49	5.32
0(GROUND)	* 1.78	* 1.78	1.94	1.12	1.25	0.73	0.90	0.53	0.86	0.50	5.16
-1	* 2.95	2.11	1.93	1.10	1.24	0.72			0.97	0.56	4.75
-2	4.05	2.15	1.94	1.12					1.26	0.74	3.99
-3	* 3.04	2.23							* 2.34	1.60	2.45

FEET



A (ft) \ B (ft)	10'		15'		MAX. REACH		A (ft)
							
15'					* 1.97	* 1.97	12' 7"
10'			* 2.42	1.48	* 1.90	1.29	16' 3"
5'	4.41	2.62	2.35	1.40	1.85	1.09	17' 5"
0 (GROUND)	4.17	2.41	2.26	1.33	1.89	1.10	16' 11"
-5'	4.15	2.38			2.38	1.39	14' 5"
-10'					* 5.29	3.85	7' 7"

1. LOAD POINT IS THE HOOK ON THE BACK OF THE BUCKET.
2. * RATED LOADS ARE BASED ON HYDRAULIC CAPACITY.
3. RATED LOADS DO NOT EXCEED 87 % OF HYD. CAPACITY OR 75 % OF TIPPING CAPACITY.



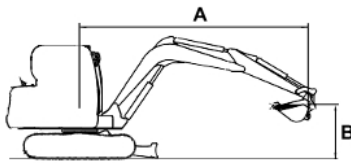







FG010679

DOZER DOWN









TRACK WIDTH	: 1.88 m (6' 2") STD TRACK
BOOM	: 3 m (9' 10")
ARM	: 1.6 m (5' 3")
BUCKET	: SAE 0.175 m ³ (CECE 0.151 m ³)
SHOE	: 400 mm (16")
	: RATING OVER FRONT
	: RATING OVER SIDE OR 360 degree
UNIT	: 1,000 kg

METRIC

A(m) \ B(m)	2		3		4		5		MAX. REACH		
											A(m)
4					* 0.97	0.86			* 0.86	0.73	4.37
3					* 1.07	0.84			* 0.86	0.58	4.96
2	* 3.07	2.39	* 1.68	1.26	* 1.35	0.81	* 1.23	0.56	* 0.92	0.51	5.26
1			* 2.49	1.17	* 1.69	0.76	* 1.38	0.54	* 1.03	0.49	5.32
0 (GROUND)	* 1.78	* 1.78	* 2.96	1.12	* 1.95	0.73	* 1.50	0.53	* 1.24	0.50	5.16
-1	* 2.95	2.11	* 3.04	1.10	* 2.04	0.72			* 1.61	0.56	4.75
-2	* 4.51	2.15	* 2.76	1.12					* 1.84	0.74	3.99
-3	* 3.04	2.23							* 2.34	1.60	2.45

FEET



A (ft) \ B (ft)	10'		15'		MAX. REACH		
							A (ft)
15'					* 1.97	* 1.97	12' 7"
10'			* 2.42	1.48	* 1.90	1.29	16' 3"
5'	* 4.50	2.62	* 3.01	1.40	* 2.12	1.09	17' 5"
0 (GROUND)	* 6.36	2.41	* 3.66	1.33	* 2.72	1.10	16' 11"
-5'	* 6.36	2.38			* 3.79	1.39	14' 5"
-10'					* 5.29	3.85	7' 7"

1. LOAD POINT IS THE HOOK ON THE BACK OF THE BUCKET.
2. * RATED LOADS ARE BASED ON HYDRAULIC CAPACITY.
3. RATED LOADS DO NOT EXCEED 87 % OF HYD. CAPACITY OR 75 % OF TIPPING CAPACITY.



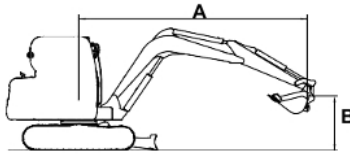







FG010732

DOZER UP









TRACK WIDTH : 1.88 m (6' 2") STD TRACK
 BOOM : 3 m (9' 10")
 ARM : 1.9 m (6' 2")
 BUCKET : SAE 0.175 m³ (CECE 0.151 m³)
 SHOE : 400 mm (16")
 : RATING OVER FRONT
 : RATING OVER SIDE OR 360 degree
 UNIT : 1,000 kg

METRIC

A(m) \ B(m)	2		3		4		5		MAX. REACH			
											A _(m)	
4										* 0.74	0.64	4.75
3					* 0.91	0.85	0.95	0.57		* 0.73	0.52	5.29
2			* 1.40	1.28	* 1.20	0.81	0.94	0.56		* 0.77	0.46	5.56
1	* 1.43	* 1.43	2.01	1.18	1.29	0.76	0.91	0.54		0.76	0.44	5.62
0 (GROUND)	* 1.71	* 1.71	1.94	1.11	1.25	0.73	0.89	0.52		0.78	0.45	5.47
-1	* 2.61	2.08	1.91	1.09	1.23	0.71	0.88	0.51		0.86	0.50	5.09
-2	* 3.90	2.11	1.92	1.09	1.23	0.71				1.07	0.62	4.40
-3	* 3.73	2.18	1.96	1.14						1.81	1.05	3.15

FEET



A (ft) \ B (ft)	10'		15'		MAX. REACH		
							A (ft)
15'					* 1.69	* 1.69	14' 0"
10'			* 2.12	1.49	* 1.62	1.15	17' 3"
5'	* 3.92	2.65	2.35	1.40	1.69	0.98	18' 5"
0 (GROUND)	4.16	2.39	2.25	1.31	1.72	0.99	17' 12"
-5'	4.10	2.34	2.22	1.28	2.09	1.21	15' 8"
-10'	4.23	2.45			4.19	2.43	10' 1"

1. LOAD POINT IS THE HOOK ON THE BACK OF THE BUCKET.
2. * RATED LOADS ARE BASED ON HYDRAULIC CAPACITY.
3. RATED LOADS DO NOT EXCEED 87 % OF HYD. CAPACITY OR 75 % OF TIPPING CAPACITY.



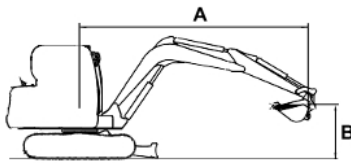







FG010734

DOZER DOWN









TRACK WIDTH	: 1.88 m (6' 2") STD TRACK
BOOM	: 3 m (9' 10")
ARM	: 1.6 m (5' 3")
BUCKET	: SAE 0.175 m ³ (CECE 0.151 m ³)
SHOE	: 400 mm (16")
	: RATING OVER FRONT
	: RATING OVER SIDE OR 360 degree
UNIT	: 1,000 kg

METRIC

A(m) \ B(m)	2		3		4		5		MAX. REACH		
											A(m)
4									* 0.74	0.64	4.75
3					* 0.91	0.85	* 1.01	0.57	* 0.73	0.52	5.29
2			* 1.40	1.28	* 1.20	0.81	* 1.13	0.56	* 0.77	0.46	5.56
1	* 1.43	* 1.43	* 2.26	1.18	* 1.57	0.76	* 1.30	0.54	* 0.85	0.44	5.62
0 (GROUND)	* 1.71	* 1.71	* 2.84	1.11	* 1.87	0.73	* 1.45	0.52	* 0.99	0.45	5.47
-1	* 2.61	2.08	* 3.03	1.09	* 2.02	0.71	* 1.50	0.51	* 1.27	0.50	5.09
-2	* 3.90	2.11	* 2.88	1.09	* 1.93	0.71			* 1.66	0.62	4.40
-3	* 3.73	2.18	* 2.17	1.14					* 2.00	1.05	3.15

FEET

A (ft) \ B (ft)	10'		15'		MAX. REACH		
							A (ft)
15'					* 1.69	* 1.69	14' 0"
10'			* 2.12	1.49	* 1.62	1.15	17' 3"
5'	* 3.92	2.65	* 2.78	1.40	* 1.77	0.98	18' 5"
0 (GROUND)	* 6.10	2.39	* 3.52	1.31	* 2.19	0.99	17' 12"
-5'	* 6.46	2.34	* 3.68	1.28	* 3.38	1.21	15' 8"
-10'	* 4.52	2.45			* 4.47	2.43	10' 1"

1. LOAD POINT IS THE HOOK ON THE BACK OF THE BUCKET.
2. * RATED LOADS ARE BASED ON HYDRAULIC CAPACITY.
3. RATED LOADS DO NOT EXCEED 87 % OF HYD. CAPACITY OR 75 % OF TIPPING CAPACITY.

FG010735



GÜNTER
GROSSMANN

Operating Controls

The "Operating Controls" section presented here consists of the following groups:

1. "Component Locations" on page 2-2
2. "Operator's Area" on page 2-4
3. "Operational Controls and Panels" on page 2-6
4. "Instrument Panel" on page 2-16
5. "Heater and Air Conditioner System" on page 2-23
6. "Stereo" on page 2-28
7. "Fuse Boxes" on page 2-29
8. "Miscellaneous Electrical Devices" on page 2-30
9. "Seat Adjustment" on page 2-32
10. "Front Windows" on page 2-36
11. "Door Side Latch" on page 2-37
12. "Cabin Storage Compartments" on page 2-38
13. "Sun Visor (Optional)" on page 2-38
14. "Hanger" on page 2-39
15. "Emergency Glass Breaking Tool" on page 2-39

Each group is explained with a point location drawing or photo and a brief description of each control, switch, gauge or valve.

Indicator lights work besides the gauges on the instrument panel. The operator should monitor machine pressure on the instrument panel along with indicator lights. These lights will only show that there is a problem.

 **WARNING**

Warning lights. When any one or more of the warning lights on the control console, comes "ON," immediately stop operation and shut down unit. Investigate and correct the problem before proceeding with operation.

COMPONENT LOCATIONS

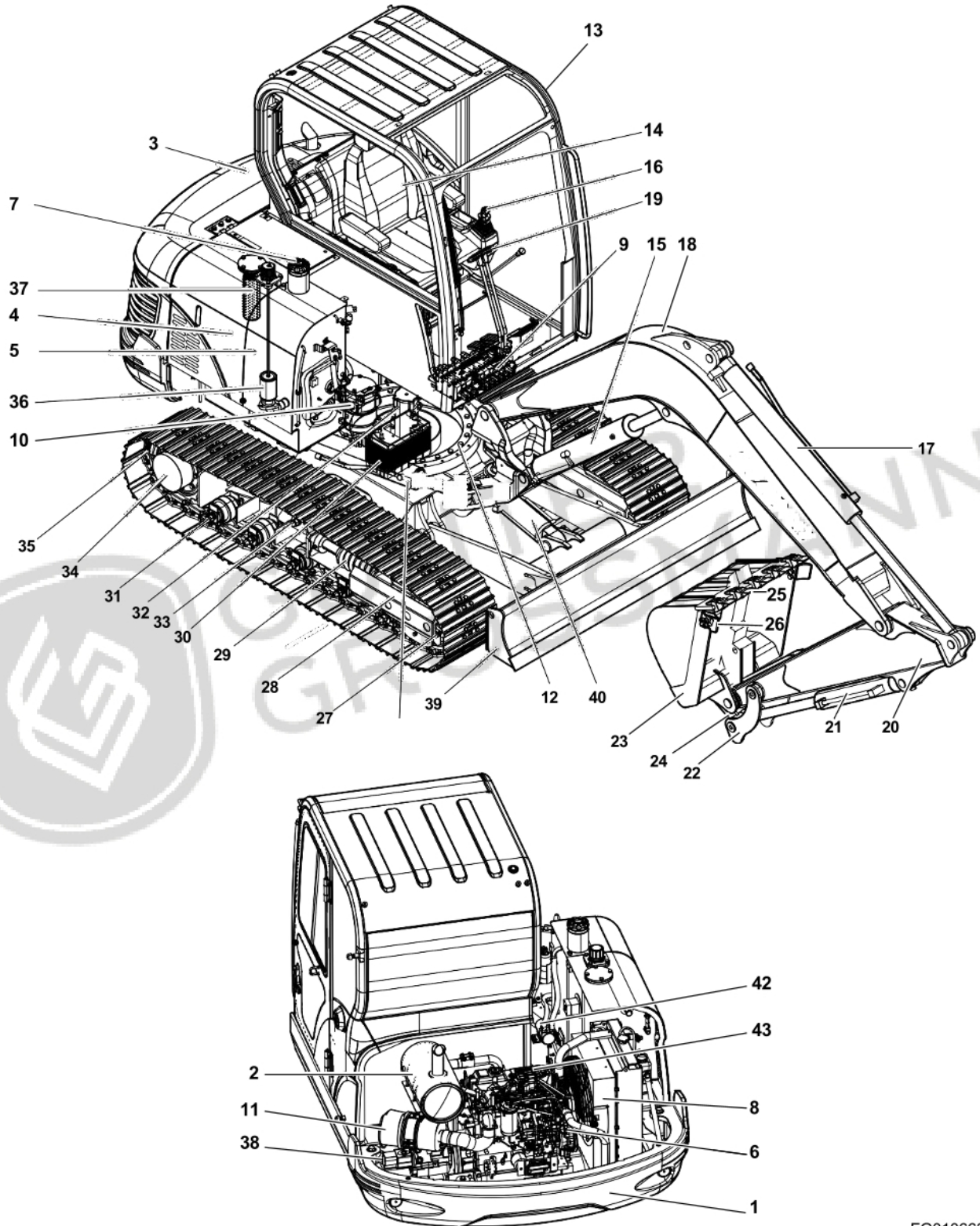

Figure 1

FG010663

Reference Number	Description
1	Counterweight
2	Muffler
3	Hood
4	Hydraulic Oil Tank
5	Fuel Tank
6	Engine
7	Fuel Tank Fill Cap
8	Radiator and Oil Cooler
9	Control Valves
10	Swing Motor
11	Air Cleaner
12	Swing Bearing
13	Cabin
14	Seat
15	Boom Cylinder
16	Work Lever (Joystick) Controls
17	Arm Cylinder
18	Boom
19	Travel Lever
20	Arm
21	Bucket Cylinder
22	Guide Link

Reference Number	Description
23	Bucket
24	Push Link
25	Tooth Point
26	Side Cutter
27	Idler
28	Track Guide
29	Track Adjuster
30	Battery
31	Lower Roller
32	Center Joint
33	Upper Roller
34	Travel Motor
35	Track Link and Shoe
36	Suction Filter
37	Return Filter
38	Pump
39	Blade
40	Dozer Cylinder
41	
42	Fuel Fill Pump
43	ECU

OPERATOR'S AREA

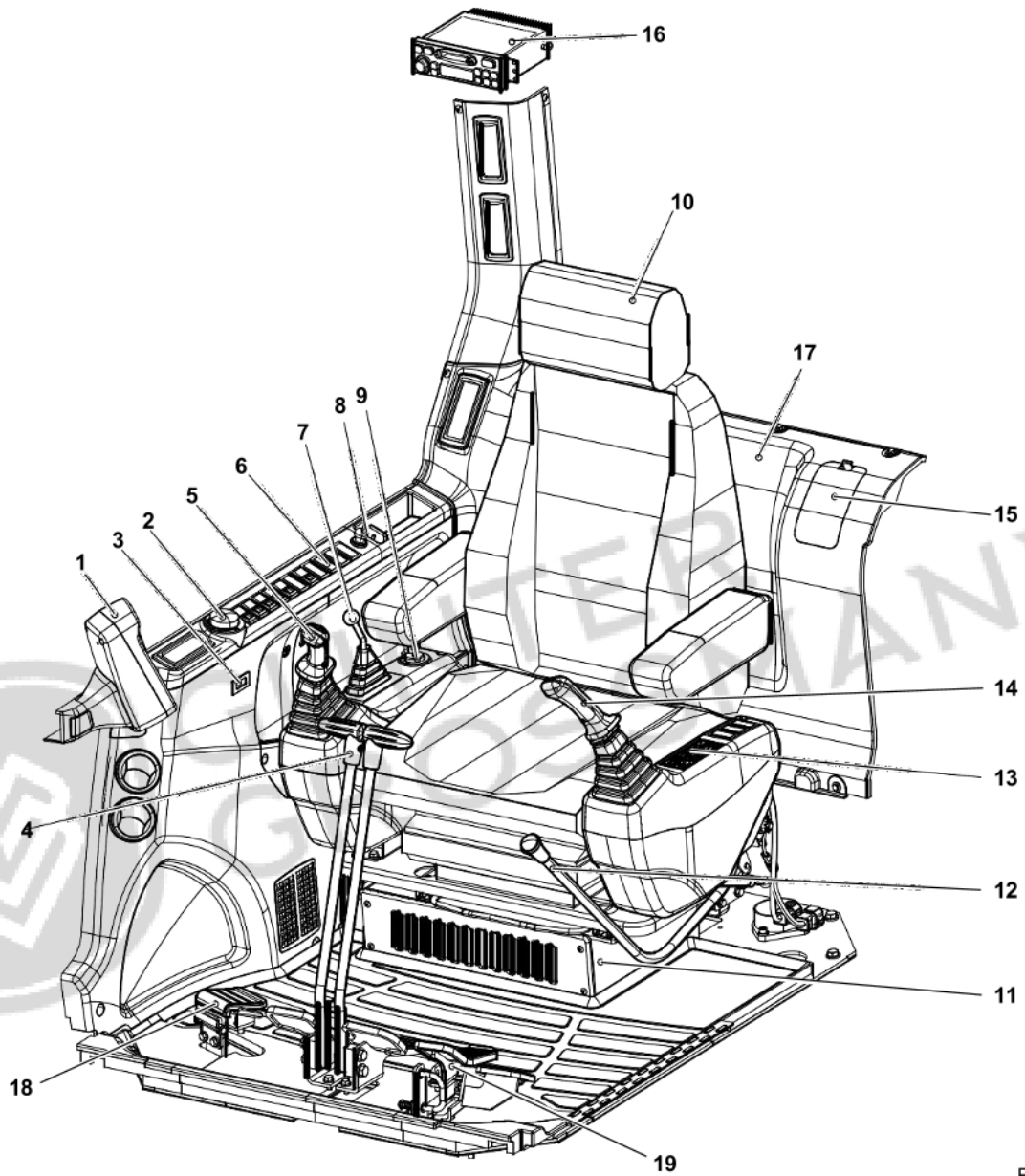

Figure 2

FG011229

Reference Number	Description
1	Instrument Panel (See page 2-16)
2	Engine Speed Control Dial (See page 2-8)
3	Hour Meter (See page 2-14)
4	Travel Levers
5	Right-hand Work Lever (Joystick) (See page 3-21)
6	Switch Panel
7	Dozer Lever (See page 3-21)
8	Cigar Lighter (See page 2-12)
9	Starter Switch (See page 2-8)

Reference Number	Description
10	Seat (See page 2-32)
11	Air Conditioner and Heater (See page 2-23)
12	Safety Lever (See page 3-14)
13	Air Conditioner Control Panel
14	Left-hand Work Lever (Joystick) (See page 3-21)
15	Fuse Box (See page 2-29)
16	Stereo (See page 2-28)
17	Electric Box
18	Boom Swing Pedal
19	PTO Pedal (Optional)



GÜNTER
GROSSMANN

OPERATIONAL CONTROLS AND PANELS

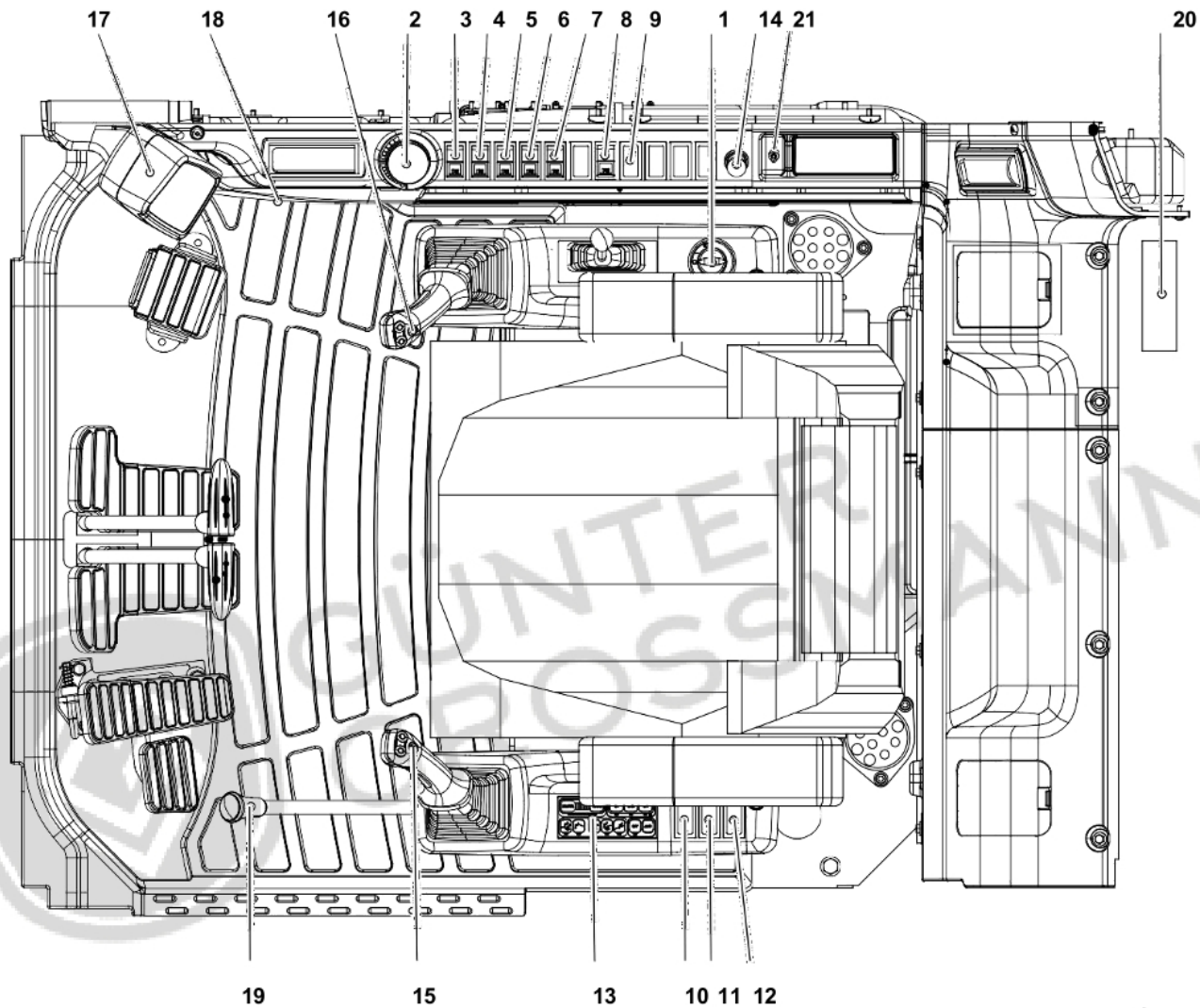

Figure 3

FG011236

Reference Number	Description
1	Starter Switch
2	Engine Speed Control Dial
3	Travel Speed Selector Switch
4	Auto Idle Switch
5	Light Switch
6	Wiper Switch
7	Windshield Washer Switch
8	Stereo ON/OFF Switch
9	Overload Warning Switch (Optional)
10	Travel Alarm Switch (Optional)
11	Warning Light Switch (Optional)

Reference Number	Description
12	Quick Clamp Switch (Optional)
13	Heater and Air Conditioner Control Panel
14	Cigar Lighter
15	Horn Button
16	Breaker Button
17	Instrument Panel
18	Hour Meter
19	Safety Lever
20	Radio
21	Engine Emergency Stop Switch

1. Starter Switch

A three-position starter switch is used to start or shut down engine for equipment operation.

- O. Turning the switch to this position turns the engine "OFF" along with its electrical system. In this position the engine is "OFF" but the interior cabin light and fuel tank transfer pump (if equipped) are functional.
- I. Turning the switch to this position turns the engine electrical system "ON" When the switch is first turned "ON" the eleven indicator/warning lights in the instrument panel, will light for approximately two seconds. The battery warning light and the engine oil pressure warning light should remain "ON" after the other nine have turned "OFF."

NOTE: *Preheat Indicator Light - The operation of the preheat cycle depends on coolant temperature. When the engine coolant is cold enough, the preheat indicator light will remain "ON" until the engine preheat cycle is completed. The preheat cycle takes about twenty seconds to complete, and the indicator light will turn "OFF" When the light turns "OFF" engage the starter.*

-  Moving switch to this position will crank engine. When engine starts, release key and allow it to return to the "I" (ON) position. Do not operate the starter switch for more than fifteen seconds at a time. This will help prevent damage to starter.

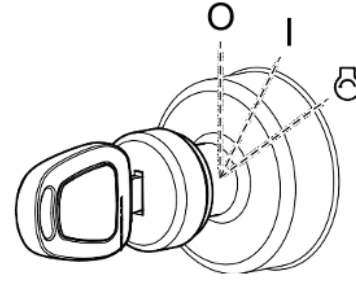

Figure 4

FG000014

2. Engine Speed Control Dial

The engine speed is controlled by the dial. Rotating it clockwise increases engine speed (rpm) and counterclockwise decreases engine speed.

A Low idle (Lowest engine speed)

B High idle (Highest engine speed)

NOTE: *The auto idle system will automatically reduce engine speed to idle speed approximately four seconds after all the control levers are in the neutral position. This system is designed to reduce fuel consumption and noise.*

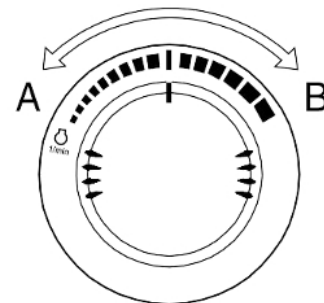

Figure 5

HAOA690L

3. Travel Speed Selector Switch



WARNING

Do not operate the travel speed selector switch when unit is in motion. Temporary loss of control could result.

- O. In this position, "LOW" travel speed is selected.
- I. In this position, "HIGH" travel speed is selected.

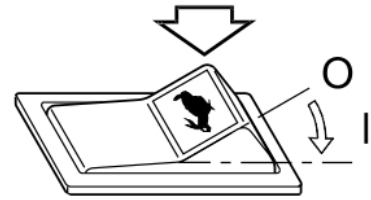

HDO20221

Figure 6

4. Auto Idle Switch

When the auto idle system is activated, the engine will automatically reduce speed to "IDLE" approximately four seconds after all the control levers are in the neutral position. This system is designed to reduce fuel consumption and noise.

- O. In this position, the auto idle system is "OFF"
- I. In this position, the auto idle system is "ON"

When the auto idle switch is located "O" position, the engine speed will returned to setting position of the engine dial and will remain at this speed despite control lever position, until the engine speed dial is moved.

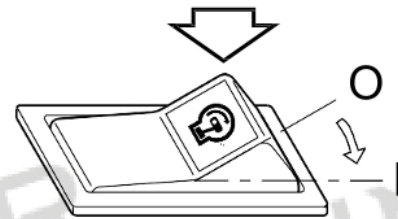

FG010202

Figure 7

5. Light Switch

This switch is used to turn "ON" the lights.

- O. In this position, all lights are "OFF."
- I. In this position, all illumination lights of the instrument panel and the control switches are turned "ON"
- II. In this position, all illumination lights and work lights are turned "ON."



CAUTION

Do not leave instrument panel or work lights "ON" when the engine is not running. Leaving lights "ON" with the engine shut down will discharge batteries.

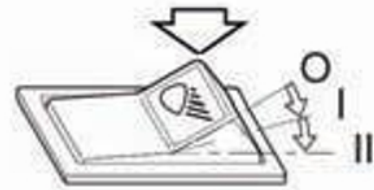

HA0A720L

Figure 8

6. Wiper Switch

- O. In this position, windshield wiper is "OFF."
- I. In this position, windshield wiper runs on approximately five seconds intermittent cycle.
- II. In this position, windshield wiper runs at constant speed.

NOTE: *Operating wiper without washer fluid or when there is sand or dirt present will damage the window and/or wiper.*

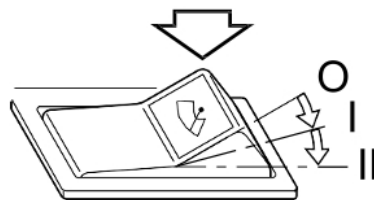

HDO2026I

Figure 9

7. Windshield Washer Switch

While the windshield wiper is running, depress the washer switch to spray windshield washer fluid onto the windshield. Use only the proper windshield washer fluid in the system.

- O. In this position, the washer is "OFF."
- I. In this position, the windshield washer sprays fluid. When released the switch returns to the "O" (OFF) position.

NOTE: *Do not operate the windshield washer without any fluid. If you operate it despite running out of fluid, the washer motor may be damaged. Check level in washer tank, and add fluid as required.*

NOTE: *If you use soapy water or synthetic detergent instead of window cleaning fluid, the wiper blade or painted surfaces may be damaged. Use standard window cleaning fluid: SSK703*

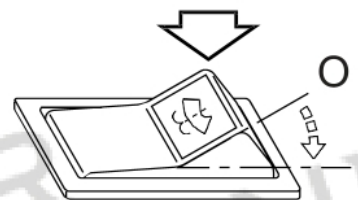

HAOA740L

Figure 10

8. Stereo ON/OFF Switch

This switch is used to turn the main power supply from the fuse box to the stereo "ON" or "OFF."

Main power to the stereo will only be turned "ON" when the starter switch is turned to the "I" (ON) position, and the stereo switch is set to the "I" (ON) position. When this is done, the normal stereo "1. The "Power/Volume Control" on "Stereo" on page 2-28 can be used to control the stereo.

If either the starter switch or the stereo ON/OFF switch (Figure 11) is turned "OFF" the stereo will be turned "OFF" regardless if "1. Power/Volume Control" "Stereo" on page 2-28, is turned "ON."

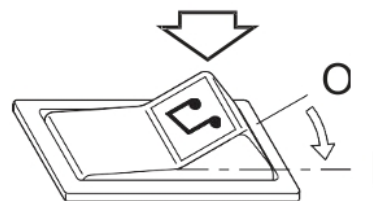

ARO0040L

Figure 11

9. Overload Warning Switch (Optional)

If unit is equipped with an overload warning device, push this switch to activate it.

- O. In this position, the overload warning device is turned "OFF."
- I. In this position, when a load is lifted that reaches the machine safe lifting limit, a warning light on the instrument panel will turn "ON" and a warning buzzer will sound.

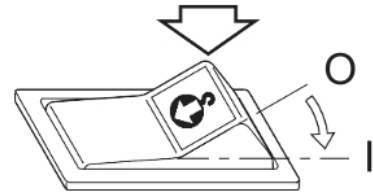

ARO0070L

Figure 12

WARNING

To prevent injury, do not exceed the rated load capacity of the machine. If the machine is not on level ground, load capacities will vary. There may be local government regulations about the use of excavators for lifting objects.

Please observe these regulations.

10. Travel Alarm Switch (Optional)

If unit is equipped with a travel alarm buzzer, push this switch to activate it, whenever traveling.

- O. In this position, the travel alarm is turned "OFF."
- I. In this position, the travel alarm will sound while traveling.

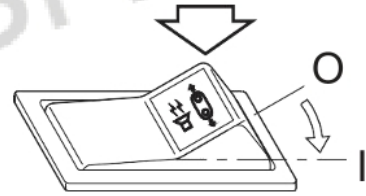

BJO2020L

Figure 13

11. Warning Light Switch (Optional)

If unit is equipped with a warning light, push this switch to activate it.

- O. In this position, the warning light is turned "OFF."
- I. In this position, the warning light turns "ON" and will start flashing.

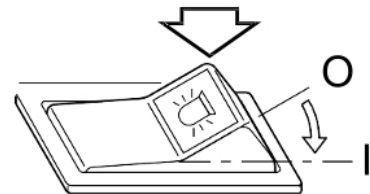

HDO2028I

Figure 14

12. Quick Clamp Switch (Optional)

Clamp releasing for interchangeable attachments is controlled.

- O. In this position, the quick clamp is "LOCKED."
The attachment is secured to the arm.
- I. In this position, the quick clamp is "UNLOCKED."
The attachment is released from the arm.

A warning buzzer will sound, and the quick clamp indicator light will turn "ON" while the switch is in "I" (UNLOCKED) position.

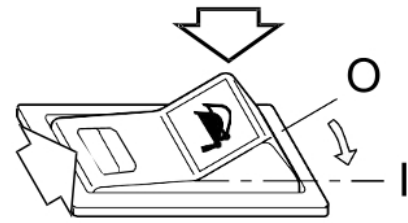

Figure 15

HB702006

WARNING

When the attachment is still connected to the machine, while the switch is in the "I" (UNLOCKED) position, do not operate the machine or the attachment might fall to the ground. It could cause personnel injuries.

13. Heater and Air Conditioner Control Panel

This panel is used to control air conditioner and heater in operator's cabin. Refer to "Control Panel" on page 2-24 for more details.

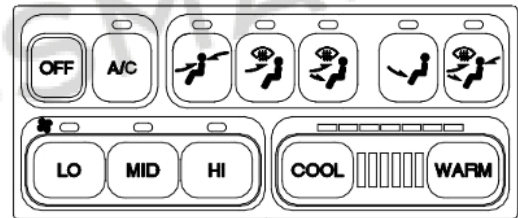

Figure 16

FG010199

14. Cigar Lighter

Push the lighter all the way into the socket and release your hand. After pushing it in, it will be ejected when it is heated. If it does not eject after a short time, pull it out and have it serviced.

CAUTION

Be careful when you handle the cigar lighter because of its radiant heat and high temperature.

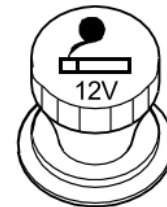

Figure 17

HA002037

15. Horn Button (Left-hand Work Lever)

Press the lower button on top of left-hand work lever (joystick) to sound horn.

NOTE: The starter switch must be "ON"

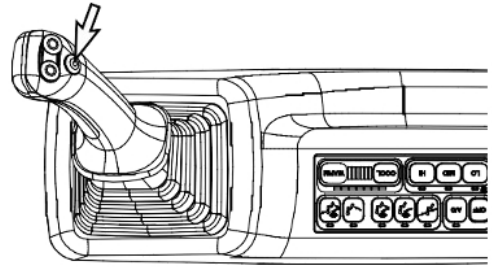

FG010518

Figure 18

16. Breaker Button (Right-hand Work Lever)

Press the lower button on the top of the right-hand work lever (joystick) to activate the hydraulic breaker.

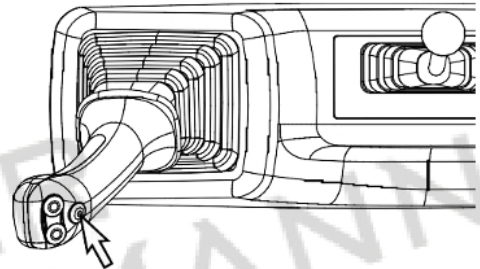

FG010519

Figure 19

17. Instrument Panel

See "Instrument Panel" on page 2-16.

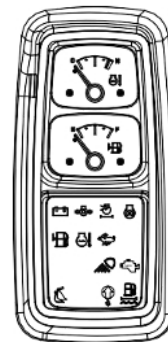

FG010741

Figure 20

18. Hour Meter

The hour meter is used to indicate the total number of running hours on the engine. The meter will flash every four seconds when the engine is running to indicate that it is functioning properly.

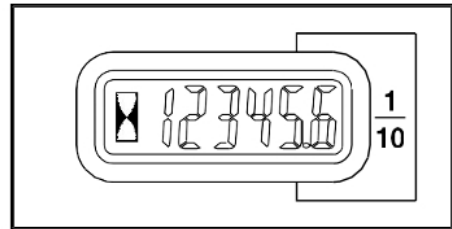

HAOA601L

Figure 21

19. Safety Lever

See "Safety Lever" on page 3-14.



Figure 22

FG010072



GÜNTER
GROSSMANN



GÜNTER
GROSSMANN

INSTRUMENT PANEL

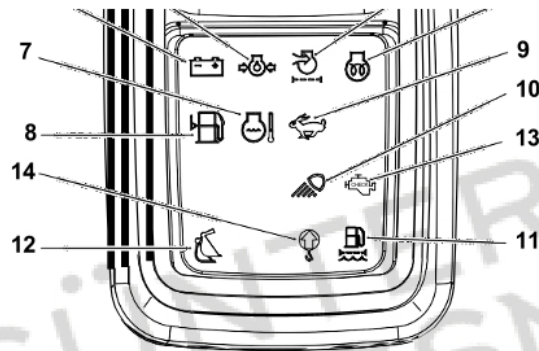

FG010730

Figure 25

Reference Number	Description
1	Engine Coolant Temperature Gauge
2	Fuel Gauge
3	Engine Oil Pressure Warning Light
4	Charge Warning Light
5	Air Cleaner Clogging Warning Light
6	Preheat Indicator Light

Reference Number	Description
7	Engine Coolant Temperature Warning Light
8	Fuel Level Warning Light
9	Hi Travel Speed Indicator Light
10	Working Light Indicator Light
11	Water in Fuel Warning Light
12	Quick Clamp Indicator Light
13	Engine Check Warning Light
14	Overload Warning Light

Functional Check

When the engine starter switch is turned to the "I" (ON) position, indicator/warning lights will turn "ON" and the alarm buzzer will sound about two seconds.

1. Engine Coolant Temperature Gauge

The colored bands indicate the temperature of the engine coolant.

WHITE ZONE (□) - Indicates temperature is within the normal operating range.

RED ZONE (■) - Indicates temperature is too high.

During operation, the pointer must be in the white zone.

If the gauge pointer moves into the red zone, the engine coolant temperature warning light will turn "ON," a warning buzzer will sound, and the engine speed will be automatically reduced. Allow the engine to run at low idle speed until the temperature gauge registers in the blue zone again. When the blue zone is reached, allow the engine to idle for an additional three - five minutes before shutting down the engine. If not allowed to idle, heat surge may develop which will damage the engine. Allowing the engine to idle will dissipate heat. Check the coolant level, look for a loose fan belt, inspect for debris around radiator, and so on.

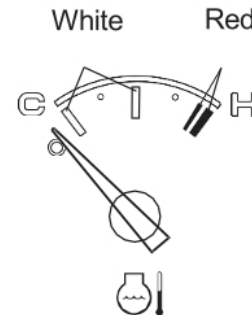

Figure 26

AXO0280L

2. Fuel Gauge

It shows remaining fuel quantity in tank.

WHITE ZONE (□) - Indicates a normal fuel quantity.

RED ZONE (■) - Indicates that fuel level is low.

If the gauge pointer moves into the red zone, the fuel level symbol will turn "ON" and be display in the screen. Stop operation and immediately and add fuel.

Check the fuel level on firm, level ground.

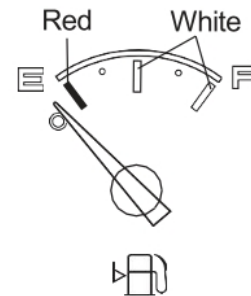
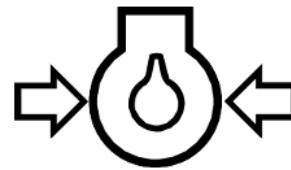

Figure 27

AXO0290L

3. Engine Oil Pressure Warning Light

This indicator light will turn "ON" when the engine starter switch is turned "ON" and should go "OFF" after the engine starts. For example, if the engine oil pressure becomes too low, the light will turn "ON" and a warning buzzer will sound. If this happens, shut the engine down immediately and determine the cause of the problem. If you continue to work when this light is "ON" it will result in serious engine damage.



HAOA620L

Figure 28



CAUTION

If you continue to work when this light is "ON," it will result in serious engine damage.

4. Charge Warning Light

This indicator light will turn "ON" when the engine starter switch is turned "ON" and should go "OFF" after the engine starts. If it does not turn "OFF" shut the engine down immediately and determine the cause of the problem.

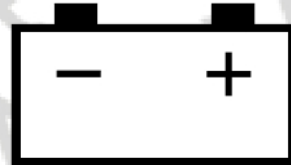

HAOA610L

Figure 29

5. Air Cleaner Clogging Warning Light

This indicator light will turn "ON" when the air cleaner filter is clogged

When it comes "ON" clean or replace the element as necessary. After the air cleaner filter has been serviced, if you place the starter switch in the "O" position and then "I" position, this indicator light turns "OFF."



FG000053

Figure 30

6. Preheat Indicator Light

In cold weather this light indicates that engine preheat function is operating.

When this indicator light turns "OFF," It means that engine preheat cycle has been completed.



Figure 31

HAOA639L

7. Engine Coolant Temperature Warning Light

If engine coolant overheats, this light will turn "ON" an alarm will sound, and the engine speed will be automatically reduced, until coolant temperature drops. Do not turn engine "OFF" because this will cause coolant temperature to rise and may cause engine to siege because of heat surge.

NOTE: Check the engine coolant temperature gauge. If the gauge pointer moves into the red zone, the engine coolant temperature warning light will turn "ON," a warning buzzer will sound, and the engine speed will be automatically reduced. Allow the engine to run at low idle speed until the temperature gauge registers in the blue zone again. When the blue zone is reached, allow the engine to idle for an additional three - five minutes before shutting down the engine. If not allowed to idle, heat surge may develop which will damage the engine. Allowing the engine to idle will dissipate heat. Check the coolant level, look for a loose fan belt, inspect for debris around radiator, and so on.

When the temperature reaches the normal range, the engine speed will automatically recover.



Figure 32

HAOD350L

8. Fuel Level Warning Light

This indicator light turns "ON" when the remaining fuel is about 6 liters (1.58 U.S. gal) or less.

When this indicator light turns "ON" fill the tank immediately.

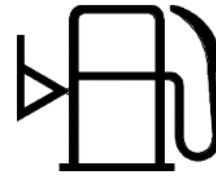

FG000057

Figure 33

9. High Travel Speed Indicator Light

The indicator light indicates that High Travel Speed is selected.

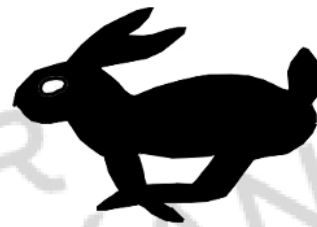

FG010190

Figure 34

10. Work Light Indicator Light

The indicator light indicates that work lights are turned "ON."



HB402003

Figure 35

11. Water in Fuel Warning Light

This indicator light will turn "ON," when the water separator is full.

When this light turns "ON," drain the water from the water separator as soon as possible.

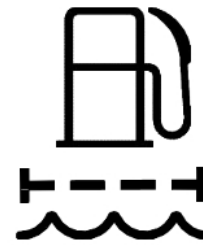

Figure 36

FG010520

12. Quick Clamp Indicator Light

This indicator light will turn "ON" when the quick clamp switch is in the "I" (UNLOCKED) position.



WARNING

When the attachment is still connected to the machine, while the switch is in the "I" (UNLOCKED) position, do not operate the machine or the attachment might fall to the ground. It would cause personnel injuries.



Figure 37

FG010192

13. Engine Check Warning Light

This indicator light will turn "ON," when the engine needs to be checked.

NOTE: *If this light turns "ON" stop the machine and repair the cause of the fault.*



Figure 38

FG000045

14. Overload Warning Light

If the overload warning switch is turned "ON," this light will turn "ON" and the warning buzzer will "SOUND," when an overloaded condition is occurring. Immediately reduce the load.



WARNING

If this warning appears on the screen and a warning buzzer sound, reduce the load immediately.

If you continue to work, the machine can be turned over or damage to hydraulic components and structural parts could occur.



Figure 39

FG000253



GÜNTER
GROSSMANN

HEATER AND AIR CONDITIONER SYSTEM

Location of Vents

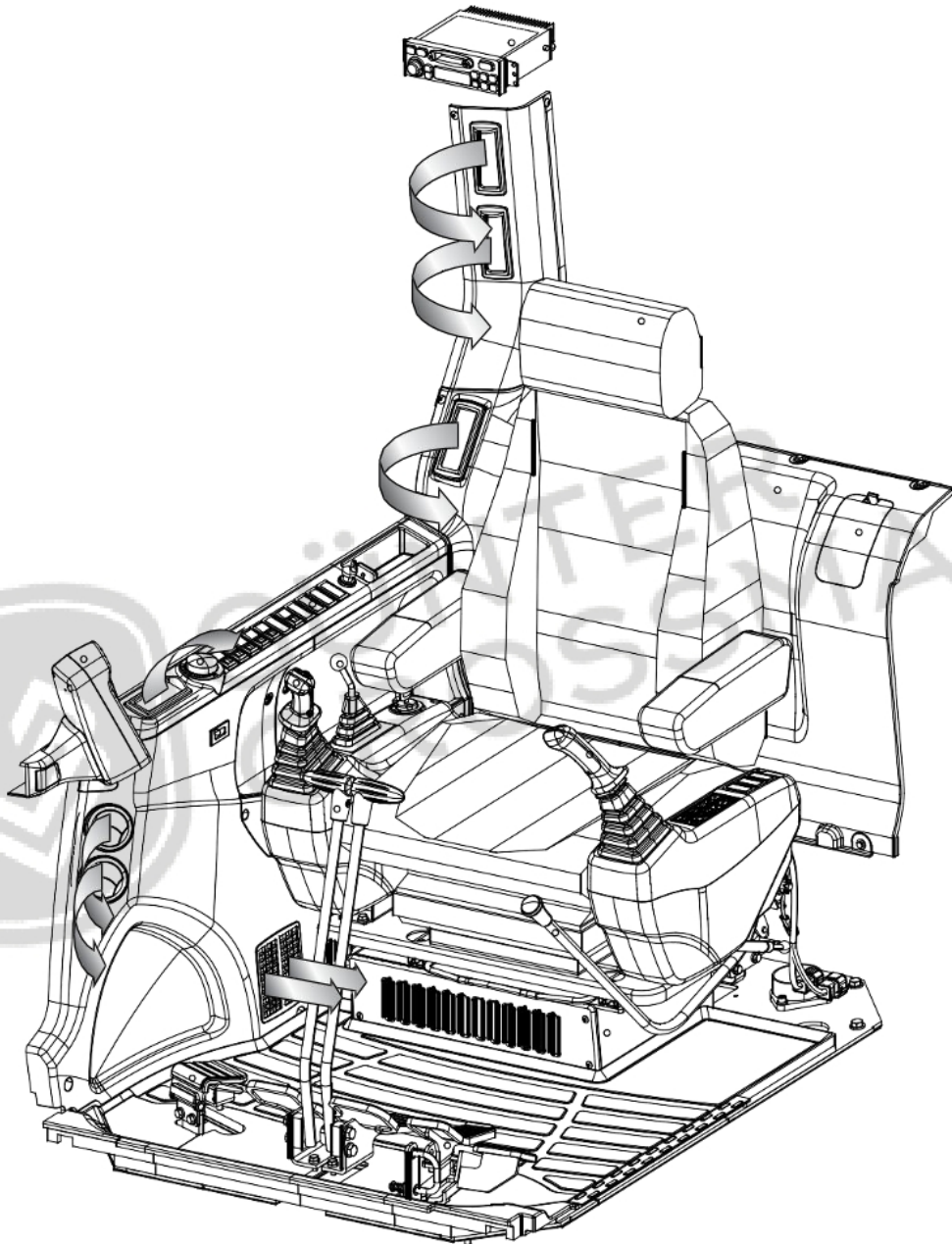

Figure 40

FG011237

The heater and air conditioner are combined into one unit under the operator's seat.

The operator can control cabin temperature using the control panel installed in the Left-hand Control Stand.

Control Panel

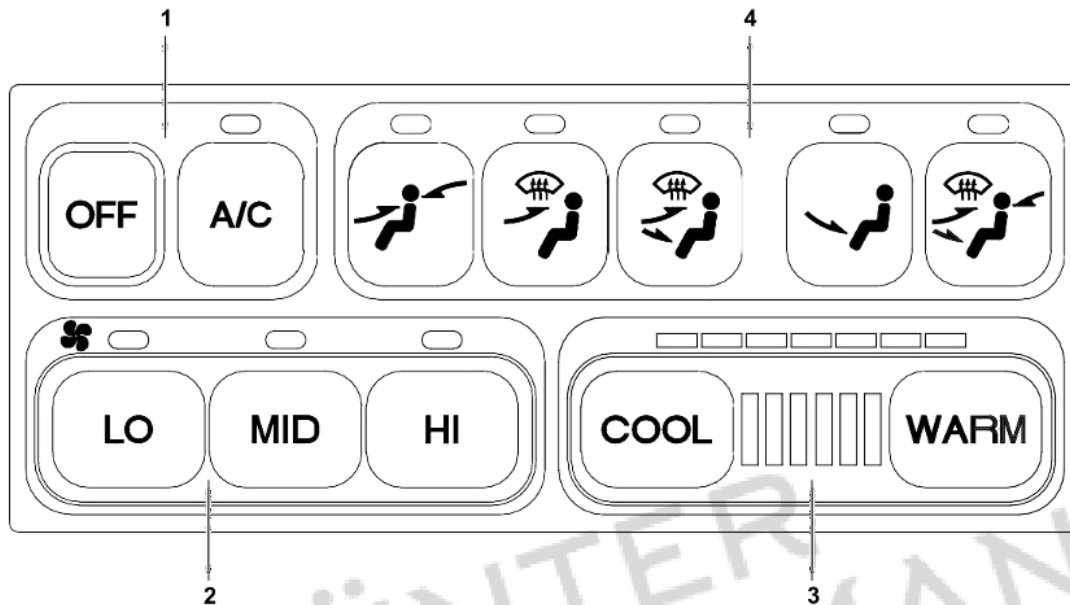

FG010193

Figure 41

Reference Number	Description
1	Fan and Air Conditioner Button
2	Fan Speed Selector Button

Reference Number	Description
3	Temperature Control Button
4	Air Outlet Selector Button

When a button is pressed, the LED indicator for the switch will turn "ON" to indicate that button is functioning and give an activation sound.

When the light switch is turned to "I" or "II" position, the LED for illumination in the control panel will turn "ON."

1. Fan and Air Conditioner Button

- A. "OFF" Button - This Button is used to control the heater and air conditioner off function by the fanstop.
- B. "A/C" Button - This Button is used to control the air conditioner ON/OFF. If you do not select a fan speed, the air conditioner will not work. When the air conditioner starts to work, the LED indicator will turn "ON."

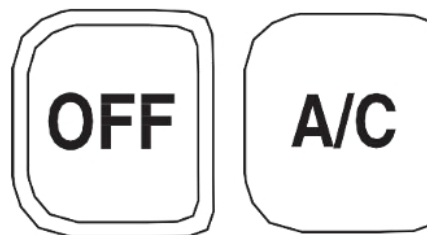

HAOC930L

Figure 42

2. Fan Speed Selector Switches

These switches are used to control the speed of the blower fan.

- A. "LO" Button - Used for low speed.
- B. "MID" Button - Used for intermediate speed
- C. "HI" Button - Used for high-speed.

NOTE: *If you do not select a blower speed the heater and air conditioner will not work.*



Figure 43

HAOC940L

3. Temperature Control Switch

The temperature control consists of 24 stages. An LED is turned "ON" for every three stages. Whenever pushing it, it changes in 24 stages. It continuously, it changes continuously.

- A. "COOL" Button - Lowers the temperature.
- B. "WARM" Button - Raises the temperature.

LED Color Status

Green LED - Air conditioner. Full green, maximum operation of air conditioner.

Red LED - Heater. Full red, maximum operation of heater.

When the unit is used only for air-conditioning, push the "A/C" switch and make all the LEDs fully green by pressing the "COOL" switch.

When the unit is used only for heat, make the LEDs fully red by pressing the "WARM" switch. The "A/C" switch has to be turned "OFF."

To set the desired temperature of air coming out of the air outlets, turn the "A/C" switch "ON" and combine red LEDs with green LEDs by pressing the temperature selector switch. The more LEDs in the green range that turn "ON" the cooler the temperature will become. The more LEDs in the red range that turn "ON" the warmer the temperature will become.

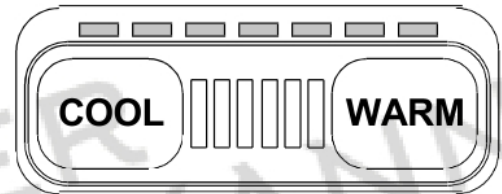

Figure 44

HAOA860I

4. Air Outlet Selector Button

- A. Used to direct airflow to upper portion of operator's cabin from both the front and rear.

This button is mainly used for air-conditioning.

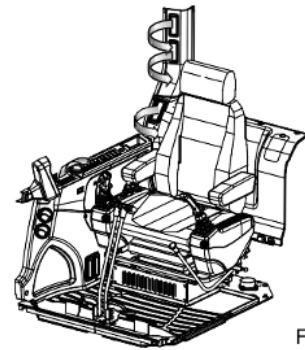

FG010194

Figure 45

- B. Used to direct airflow to the front window and to upper portion of operator's cabin from the front.

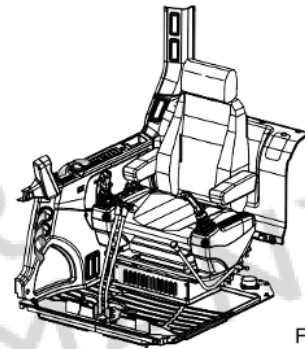

FG010195

Figure 46

- C. Used to direct airflow to upper portion of operator's cabin from the front and to lower portion of operation's feet.

It will also deliver air to the front window.

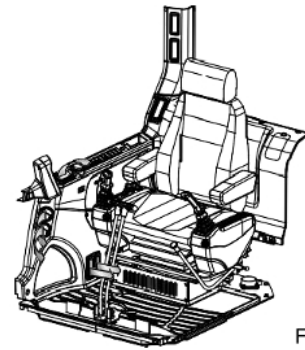

FG010196

Figure 47

- D. Used for direct airflow to lower portion of operator's cabin and feet.

This mode is mainly used for heating.

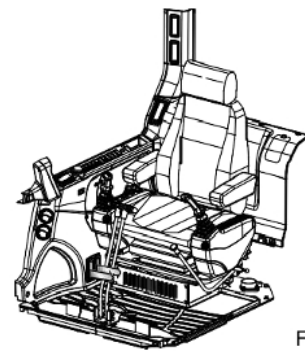

FG010197

Figure 48

- E. Used to direct airflow to upper portion of operator's cabin from both the front and rear.
It will also deliver air to the front window and to operator's feet.

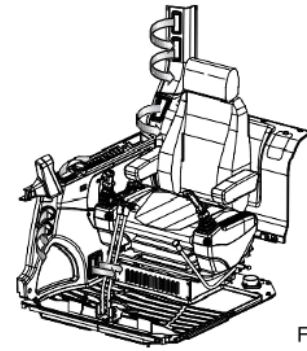

FG010198

Figure 49

There are two ventilation nozzles that are located in front of the front window.

These nozzles can control the direction and the flow of air.

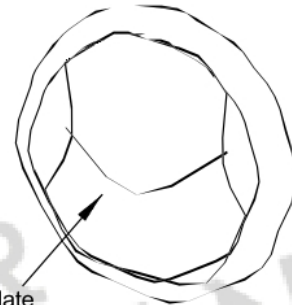

Plate

FG010731

Figure 50

Memory Function of Used Mode

The air conditioner panel has a memory function. When the starter switch is turned "OFF" the setting for the panel, will be stored. When the excavator is started, the last stored setting will be used.

Additional Operating Instructions

1. A proper indoor temperature in summer is 5 - 6°C (10 - 12°F) less than the outdoor temperature.
NOTE: *The blower switch should be on "LO" speed.*
2. Replace filter every 6 months or when required because of operating conditions. Replace filter when required.
3. If operating the air conditioner or heater for a long time, operate the ventilation switch, and when smoking, vent the air to the outside to prevent irritation to eyes.

STEREO

Before operating the stereo or CD player, read operation manual enclosed with stereo or CD player.

Stereo

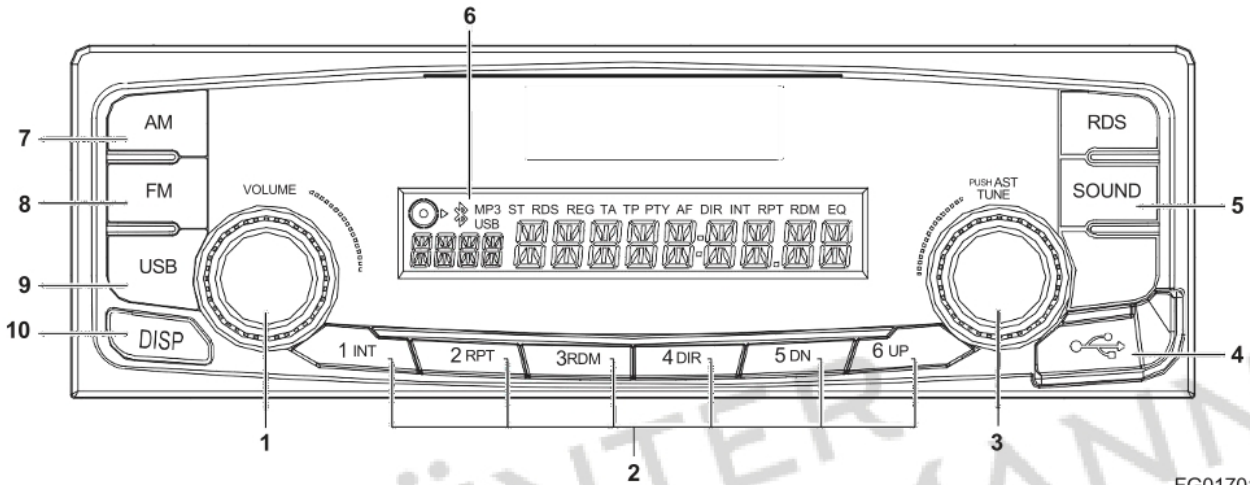

FG017016

Figure 51

Reference Number	Description
1	Power / Volume Control
2	Preset Station
3	Tuning Up / Down
4	USB Loading Port
5	Sound Mode Selector

Reference Number	Description
6	LCD
7	AM Selection
8	FM Selection
9	USB Selection
10	Display Mode Control

CD Player (Optional)

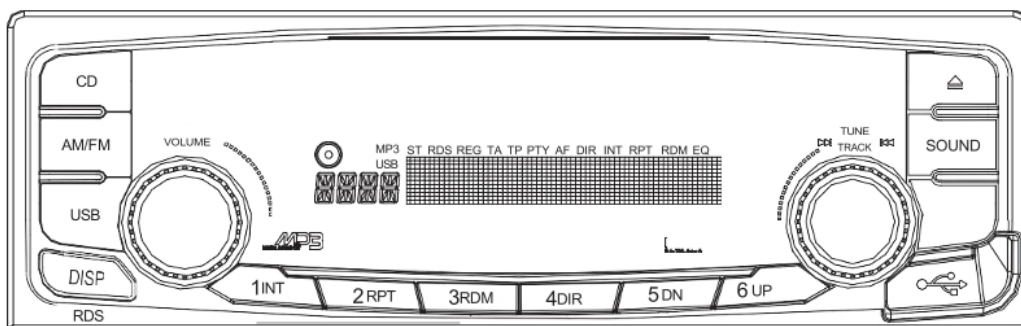

FG017017

Figure 52

FUSE BOXES

There is a fuse box under the left-hand control stand. The fuses prevent electrical devices from overloading or shorting.

A decal attached to the top of the fuse box's cover indicates the function and amperage of each fuse.

Spare fuses are mounted on the inside of fuse box's cover. (One each of a 10A, 15A, 20A and 30A.)

Change a fuse if the element separates. If the element of a new fuse separates, check the circuit and repair the circuit.

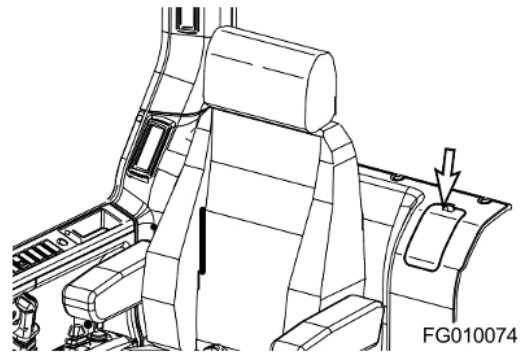

Figure 53

CAUTION

Always replace fuses with the same type and capacity fuse that was removed. Otherwise, electrical damage could result.

Fuse Identification

No.	Fuse Box	
	Name	Capacity
1	Beacon (Optional), Travel Alarm (Optional) Quick Clamp (Optional),	10A
2	Hi Speed, Pilot Cut Off, Cabin Light (Optional)	10A
3	Wiper Motor, Windshield Washer	10A
4	A/C Panel, Stereo Control Unit,	10A
5	Gauge Panel, Pilot Buzzer	10A
6	Horn, Breaker, 2-Way	10A
7	EGR Valve	10A
8	Starter Switch	10A
9	Can Checker	15A
10	Cigar Lighter	15A
11	Condenser Fan, Compressor	20A
12	A/C Unit	20A
13	Fuel Pump, Room Light	20A
14	Working Light, Headlight	30A

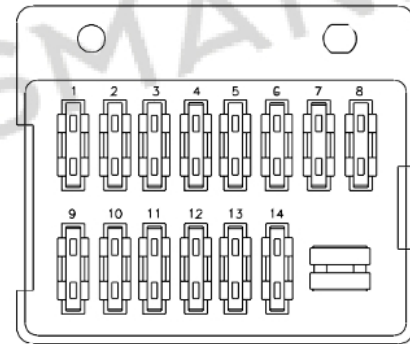

Figure 54

MISCELLANEOUS ELECTRICAL DEVICES

Cabin Light

A light is installed on the top of the operator's cabin.

The light will work despite starter switch position.

NOTE: *If light is left "ON" for a long time while the engine is not running, the battery will be discharged.*

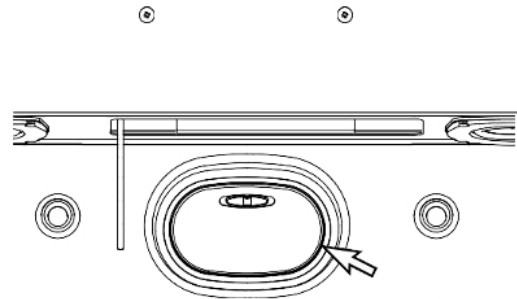

FG000417

Figure 55

Pilot Cutoff Switch

When the safety lever is put into the "LOCK" position, the switch deactivates the work and travel levers. With the work and travel levers deactivated, no digging/operational work can be done.

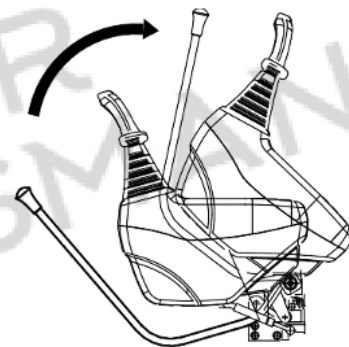

FG010050

Figure 56

Circuit Breaker

A main circuit breaker is in the battery box. It will automatically cut off in case of an electrical short circuit or overload. This will prevent the electrical wiring and components from being burned or damaged.

If the circuit breaker is cut off, check all related circuits, this means something is wrong in the electrical circuit.

After maintenance, press the red button for normal operation of circuit breaker.

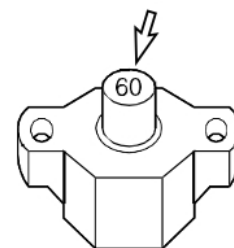

HAAE2110

Figure 57

Fusible Link

A fusible link is in the battery box.

If the engine does not crank, first check that starter switch is turned "ON" and that no power is available (No indicator lights will light.). Check that "A" portion (Figure 58) of the fusible link is not broken or burned through. Replace the fusible link if damage and investigate cause.



WARNING

When changing the fusible link, replace the fusible link with the same capacity part. Otherwise, a fire could break out in the wiring harness and/or other components of the circuit. Always use original *Günter Grossmann* parts.

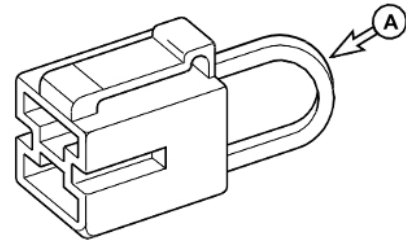

Figure 58

HAAE2120



GÜNTER
GROSSMANN

SEAT ADJUSTMENT

WARNING

Adjust the seat position before starting operation or after changing the operator.

Always fasten seat belt while operating machine.

Adjust the seat so the control levers and pedals can be operated freely and easily with the operator back against the backrest.

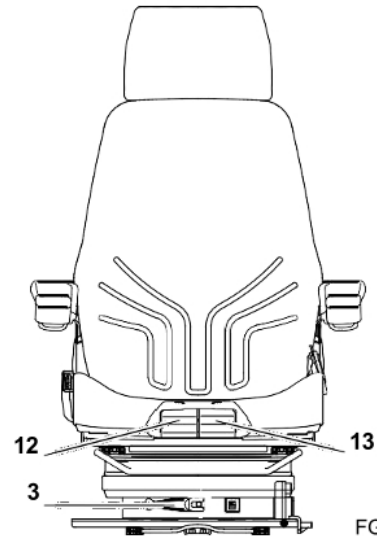

FG010765

Figure 59

1. Forward / Backward Adjustment

Holding lever (1, Figure 60), raise it up, allows the seat to be moved to desired position. Release lever to lock the seat in the selected position. Adjustment range is 160 mm (6.3 in).

2. Seat Height Adjustment

With no load on the seat (getting up from the seat slightly), the seat height can be adjusted by pulling up on lever (2, Figure 60) in stages.

The seat automatically moves down to its lowest point after it is moved to the highest point. Seat height can then be adjusted to desired height again.

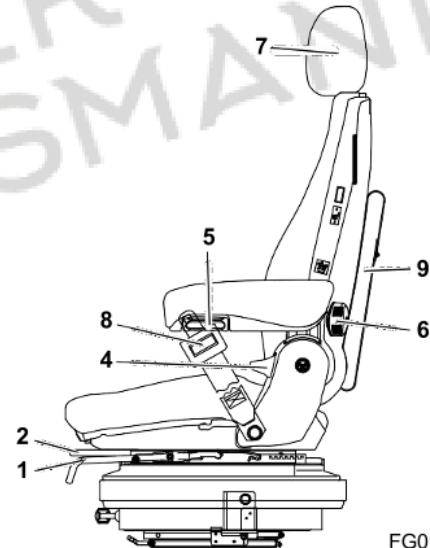

FG010766

Figure 60

3. Suspension Adjustment

Turning lever (3, Figure 59) to right makes the suspension harder. Turning lever to left makes the suspension softer. Adjust according to operator's weight by checking the weight indicator by side of lever. Adjustment range is from 50 - 120 kg (110 - 265 lb).

4. Backrest Adjustment

Lifting up the adjustment lever (4, Figure 60) under the front of the seat adjusts the seat back to obtain the desired backrest angle.

5. Armrest Angle Adjustment

The angle of each armrest can be adjusted by turning a dial (5, Figure 60) on bottom of armrest. When adjusting the angle, manually raise the armrest before turning the dial.

6. Lumbar Support Adjustment

A lumbar support is located in the seat back.

Turn the dial (6, Figure 60) counterclockwise to increase the force of the lumbar support

7. Headrest

The headrest (7, Figure 60) can be adjusted forward/ backward and up/down. Move it by holding both sides.

8. Seat Belt



WARNING

The seat belt is for the operator's safety and should always be worn. Before driving the machine, adjust the seat to the desired position for maximum comfort and machine control, then fasten the seat belt. Seat belts must be worn across the pelvic region and adjusted snugly to lessen the chance and severity of injury in case of an accident. Never fasten a seat belt across the abdomen.

Under no circumstances should the operator be standing in the cabin when operating the excavator.

Do not adjust the seat position while the vehicle is moving because a loss of control may result. Stop the machine, apply the parking brake, and then adjust the seat.

Always, check the condition of seat belt and belt bracket before fastening it. Do not use it with twists in it. Replace belt or bracket if damaged or worn.

Seat Belt Locking and Unlocking

Insert belt end (1, Figure 61) into the buckle (2). Pull the belt to check that belt end is locked into buckle.

Adjust belt length so it is comfortably tight against the operator's pelvic region (hipbone).

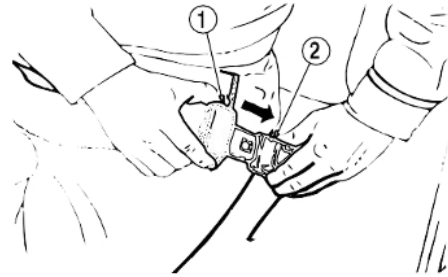

HAOB140L

Figure 61

Press the button (3, Figure 62) in the center of buckle (2) and pull out belt (1) to unlock.

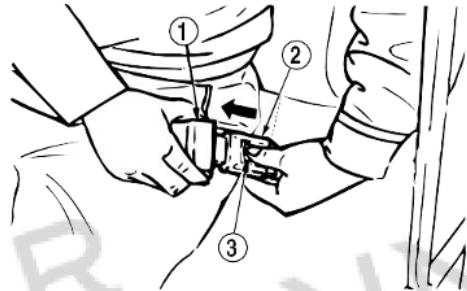

HAOB150L

Figure 62

9. Seat Back Pocket

The seat has a seat back pocket. It is used for storing the operation and maintenance manual.

10. Heating the Operator's Seat (Optional)

The operator's seat can be heated. The switch on the left side of the seat back is used to warm the seat. When heating is not needed or seat is warmed, turn the switch to "OFF" position.

11. Two-grade Forward / Backward Adjustment

For operator's convenience, the right and left control stands and seat can slide together, within a 110 mm (4.3 in) forward or backward travel distance.

Holding lever (11, Figure 63), raise it up, set the seat to desired position. Release lever to lock the seat in the selected position.

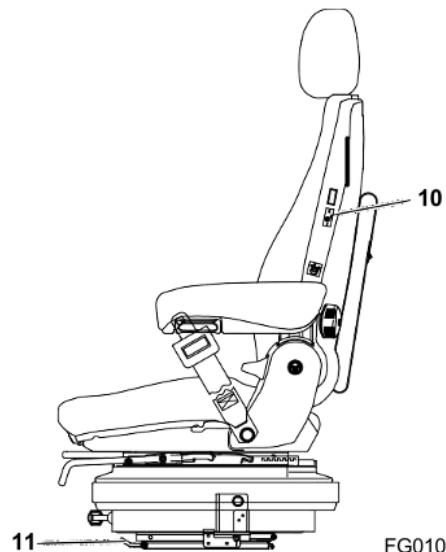

FG010767

Figure 63

12. Seat Forward / Backward Adjustment

The seat cushion can be shifted forward and backward by pulling the lever (12, Figure 59).

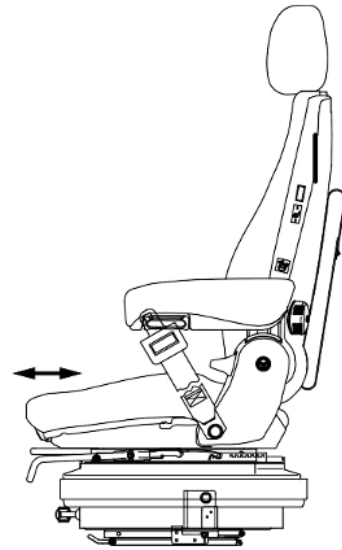

FG010768

Figure 64

13. Seat Angle Adjustment

The seat cushion can be shifted tilted up and down by pulling the lever (13, Figure 59).

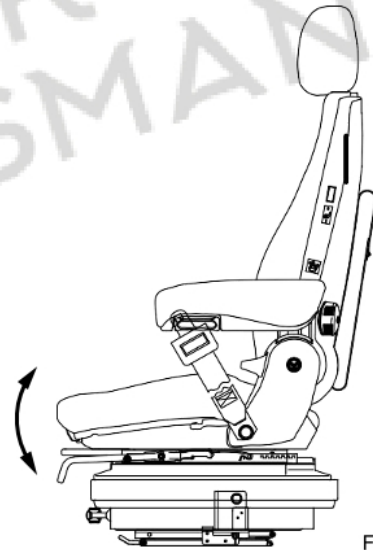

FG010769

Figure 65

FRONT WINDOWS

WARNING

When leaving operator's seat, set the safety lever to "LOCK" position (Figure 66), if not a serious accident could occur by accidentally moving the work levers.

Front Upper Window

The front upper window can be housed in the cabin's ceiling.

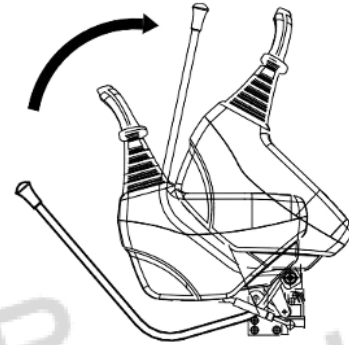

Figure 66

FG010050

Opening the Window

WARNING

When stowing front window in the cabin roof, make sure both release levers (1, Figure 67) are latched.

1. Lower bucket to ground.
2. Set safety lever (Figure 66) on "LOCK."
3. Set engine speed control dial to "LOW IDLE" Allow engine to idle for 3 - 5 minutes.
4. Shut down engine by turning key to "O" (OFF) position.
5. Hold the window handles (2, Figure 67), then pull the lock levers (1) to release the lock. The top of the front window will come out.
6. Pull window up, and push it against lock pin at the rear of the cabin. Make sure that it is securely latched.
7. Check that lock levers are securely latched in the lock position.

NOTE: When the front upper window is open, never extend your head or body through the window frame.

NOTE: If the window happens to fall with a strong impact against the machine, while some part of your body is extended out of the cabin, it may result in bodily injury.

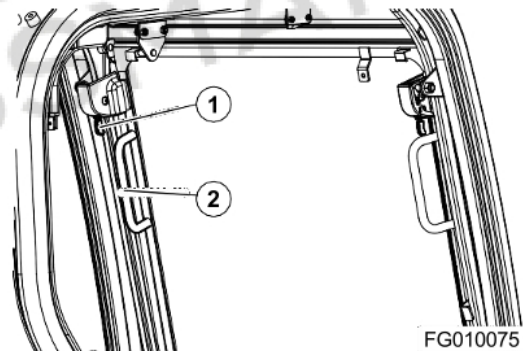

Figure 67

FG010075

! WARNING

Be careful that your hands are not caught in window frame.

1. Lower bucket to ground.
2. Set safety lever (Figure 66) on "LOCK" and shut down engine.
3. Holding upper handles (1, Figure 68) of front window with left and right-hand, pull lock levers (2, Figure 68) to release the lock.
4. Push window forward, and lower it slowly.
5. When the bottom of the window, reaches the top of the front bottom window, push the front window to engage the lock (2, Figure 67).
6. Check that lock levers are securely latched in the lock position.

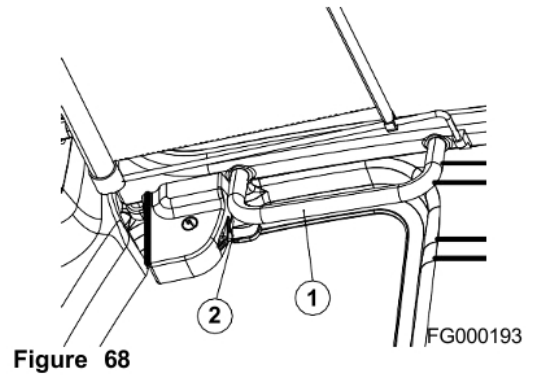

Front Bottom Window

The front bottom window can be removed.

1. After stowing the front upper window in the cabin ceiling, remove bottom window (1, Figure 69) from cabin in direction of the arrow.

! WARNING

Never have wet hands when handling a window. Never drop window or let it come into contact with other parts of the machine.

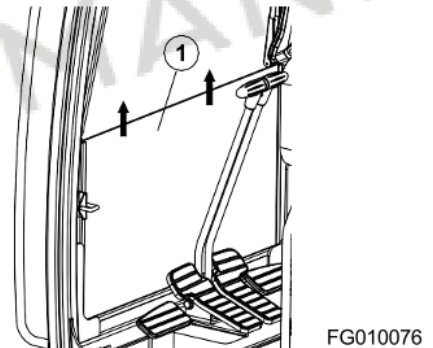

DOOR SIDE LATCH

1. The door side latch (1, Figure 70) is used to secure the door to the side of the cabin when it is opened.

NOTE: *Keep the door closed and locked when machine is not in use.*

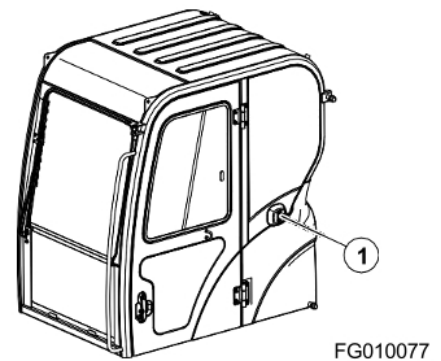

- To release door from side of cabin, push the latch lever (1, Figure 71) down. The latch lever is to the left of the operator's seat.

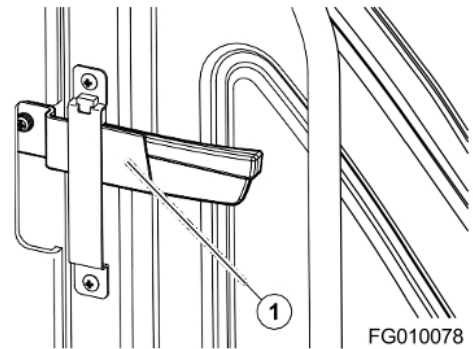

Figure 71

CABIN STORAGE COMPARTMENTS

There are three storage compartments to the right of the operator's seat.

There is a separated small tray (1, Figure 72) on the right side of operator's seat.

Two storage compartments (2 and 3, Figure 72) are below the switches to store larger items.

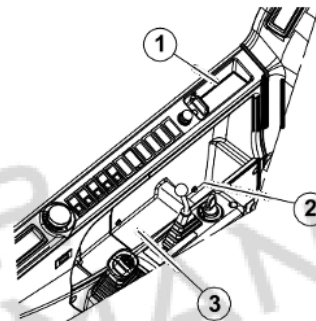

Figure 72

SUN VISOR (OPTIONAL)

The sun visor can be used to reduce the amount of sunlight coming through the front window and ceiling.

When wanting to reduce the amount of sunlight coming in the front window, pull bar (1, Figure 73) down, and secure it in each bracket (2, Figure 73).

When not wanting sun visor, pull bar down out of the brackets. This will allow to the sun visor to retract.

NOTE: Do not allow the sun visor to roll backup without holding it. Not holding it may result in damage to the sun visor and retract mechanism.

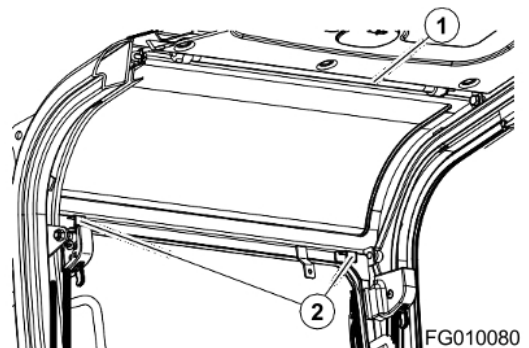

Figure 73

HANGER

A hanger (1, Figure 74) is located on the upper left side of the operator's cabin.



WARNING

Do not hang anything that will easily fall down, or will impair your view out of the cabin.

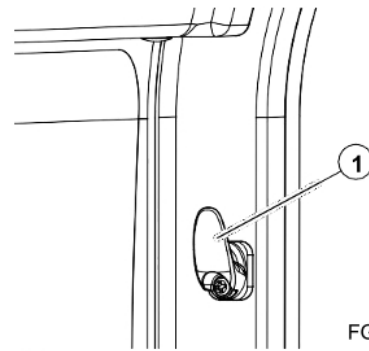

FG010081

Figure 74

EMERGENCY GLASS BREAKING TOOL

The excavator is equipped with a glass breaking tool. It is at the upper left side of the operator's seat. This tool can be used in case of an emergency which requires the breaking of glass to exit from the cabin. Grip the handle firmly and use the sharp point to break the glass.



WARNING

Protect your eyes when breaking the glass.

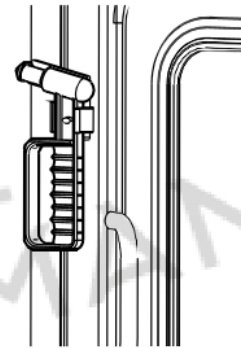

FG010052

Figure 75



Operation

TO HANDLE A NEW EXCAVATOR

All *Günter Grossmann* excavators are inspected and adjusted before leaving the factory. However, it is required that operator follow these steps during the initial break-in period. Failure to follow these steps may result in damage to the equipment or reduced performance.

Hour	Load
For first 50 hours of operation.	Maintain about 80% load of full capacity (Engine rpm: 80% of rated rpm)
After first 50 hours of operation.	Full load

If machine is used at full load before it is broken in, it may affect the life cycle and safe running operations. This could lead to problems later.

- NOTE:**
1. *Check daily for leakage of coolant, fuel, engine oil and hydraulic oil.*
 2. *Inspect all lubricants daily, add appropriate lubricants as required.*
 3. *During operation, monitor all instruments and gauges from time to time.*
 4. *Avoid an extreme engine load.*
 5. *Operate unit at 80% load until engine and all other components are at operating temperature.*
 6. *Check that work equipment is operating normally during operation.*
 7. *Check machine for loose parts or for damage that may have occurred during shipping.*
 8. *Check for loose wiring or terminals, check gauge operation and battery electrolyte level.*

STARTING AND STOPPING THE ENGINE

Inspection Before Starting Engine



WARNING

If a flammable materials such as leaves, paper, etc. are allowed to accumulate on high temperature components, such as the engine muffler and turbo, a fire may occur. Fuel, lubricant and hydraulic oil leaks, may cause a fire. If there is anything wrong, perform the appropriate corrective action.

Before starting engine, inspect the following items:

1. Electric system - Check for damaged electrical cables, and loose or missing connectors.
2. Fuel system - Drain water and sediment from fuel tank and water separator.
3. Hydraulic system - Check for hydraulic oil leaks, damaged tubing and hoses, and interference points of components.
4. Lubrication - Perform all daily and periodic maintenance services. Perform services according to reading shown on hour meter.
5. Safety - Perform a machine walk-around. Make sure that no one is under the machine or performing any maintenance on it, before starting engine.
6. After starting machine - Check that all operational controls and components, are in proper operating condition, and are functioning correctly. Stop operation and correct any malfunction before continuing work.

Operational Checks Before Starting Engine



WARNING

When leaving operator's seat, set the safety lever to "LOCK" (Figure 1) position, if not a serious accident could occur by accidentally moving the travel or work levers.

1. Set safety lever on "LOCK" (Figure 1).
2. Fasten seat belt. Check for proper operation and condition.
3. Set all operation levers in "NEUTRAL."

NOTE: Be careful not to touch any switches when starting engine.

4. Rotate the starter switch to the "I" (ON) position (Figure 2). Check all indicator lights. A warning buzzer will sound for about two seconds. After two seconds, all lights except the following will turn "OFF."
 - Charging warning light
 - Engine oil pressure warning light
 - Engine coolant temperature gauge
 - Fuel gauge

NOTE: If all the indicator lights do not come "ON" when the key is first turned, there is a problem.

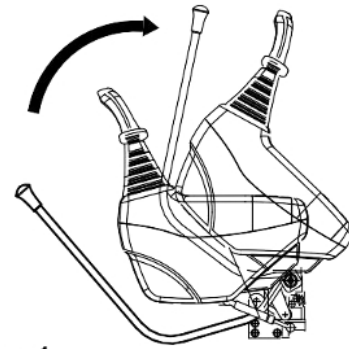

FG010050

Figure 1

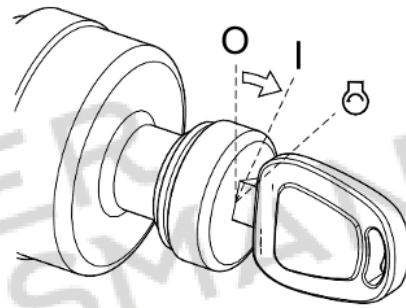

FG000084

Figure 2

Engine Start



WARNING

Start the engine after sounding horn and making sure there are no people or obstacles in the area.

1. Perform all steps in "Operational Checks Before Starting Engine" on page 3-3.
2. Set engine speed control dial slightly above "LOW IDLE" (Figure 3).
3. Sound horn.

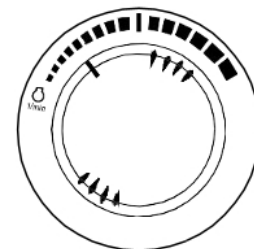

HAOB34L

Figure 3

- Turn starter switch to "O" (START) position (Figure 4). Engine should start in approximately five seconds.



WARNING

If the engine does not start after approximately fifteen seconds of cranking, release the starter switch. Wait about five minutes and repeat above step.

- After engine has started, release key. Key will return to the "I" (ON) position (Figure 4).
- Follow procedures in "Hydraulic System Warm-up" on page 3-9.
- After warming unit, check all operating indicators to make sure that all engine systems (oil pressure, coolant, etc.) are in the normal operating range. If any problems are noticed, shut down engine.

Normal indicators are:

No.	Instrument Panel Light or Gauge	Indicator Reading
1	Engine Coolant Temperature Gauge	White Range
2	Fuel Gauge	White Range
3	Engine Oil Pressure Warning Light	OFF
4	Charging Warning Light	OFF
5	Engine Coolant Temperature Warning Light	OFF
6	Engine Check Warning Light	OFF

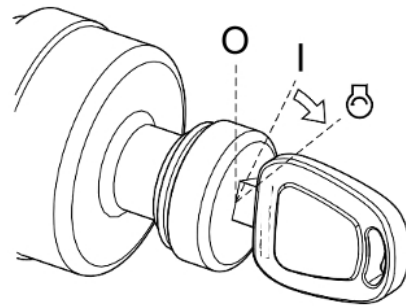

Figure 4

FG000085

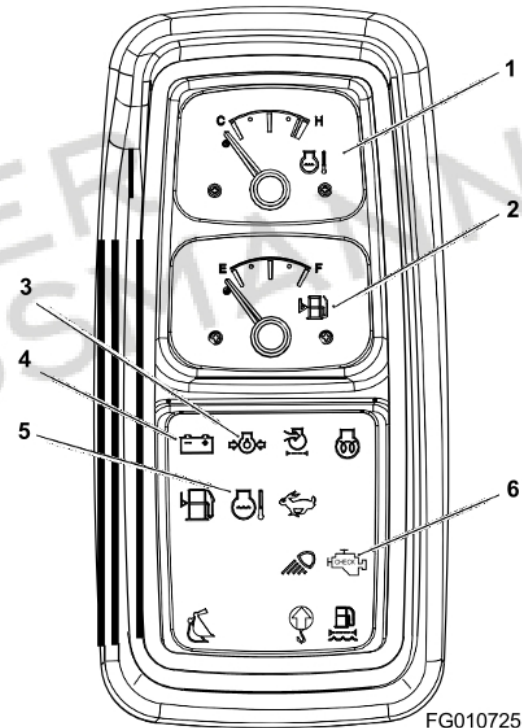

Figure 5

FG010725

8. Check color of exhaust smoke.
 - No color or light blue - Engine is running in good condition.
 - Black - Incomplete combustion. Check cause.
 - White or dark blue - Engine is burning engine oil. Check cause.
9. Check for usual engine vibration and noises. If any are heard or felt, investigate cause.

NOTE: *If engine coolant temperature gauge pointer moves into the red zone, the engine coolant temperature warning light will turn "ON" a warning buzzer will sound, and the engine speed will be automatically reduced. Allow the engine to run at low idle speed until the temperature gauge registers in the blue zone again. When the blue zone is reached, allow the engine to idle for an additional three - five minutes before shutting down the engine. If not allowed to idle, heat surge may develop which will damage the engine. Allowing the engine to idle will dissipate heat. Check the coolant level, look for a loose fan belt, inspect for debris around radiator, and so on.*



GÜNTER
GROSSMANN

Cold Weather Starting

WARNING

DO NOT USE STARTING FLUIDS. The preheat system could cause the starting fluid to explode. Starting fluids should never be used.

1. Perform all steps in "Operational Checks Before Starting Engine."
2. Set engine speed control dial slightly above "LOW IDLE" (Figure 6).
3. Sound horn.

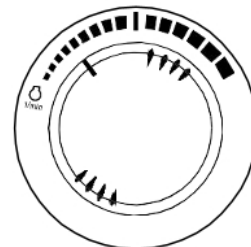

Figure 6

HAOB34L

4. Turn starter switch to the "I" (ON) position (Figure 7). When preheat cycle is completed, the preheat indicator light (1, Figure 8) will turn "OFF."

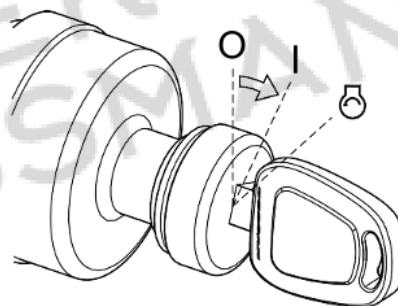

Figure 7

FG000084

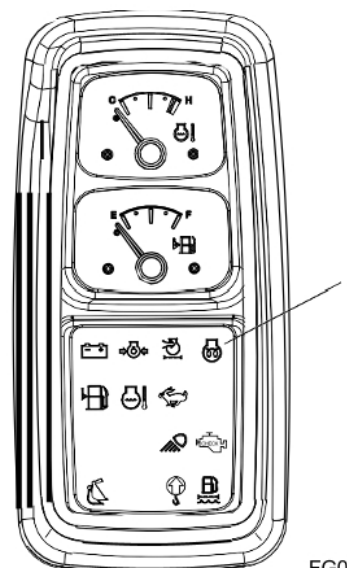

Figure 8

FG010726

5. After the preheat completion, immediately turn starter switch to "O" (START) position (Figure 9). Engine should start in approximately five seconds.



WARNING

If the engine does not start after approximately fifteen seconds of cranking, release the starter switch. Wait about five minutes and repeat above step.

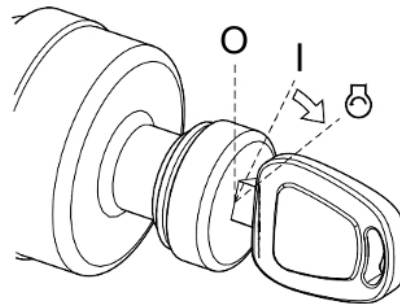

FG000085

Figure 9

6. After engine has started, release key. Key will return to the "I" (ON) position (Figure 9).
7. After the engine starts, check all operating indicators to make sure that all engine systems (oil pressure, coolant, etc.) are in the normal operating range. If any problems are noticed, shut down engine.
8. Follow "Hydraulic System Warm-up" procedures in this section.

Starting Engine With a Booster Cable



WARNING

1. An explosive gas is produced while batteries are in use or being charged. Keep flames or sparks away from the battery area.
 2. Charge batteries in a well ventilated area.
 3. Always wear eye protection when starting a machine with jumper cables.
 4. Improper jump-starting procedures can cause an explosion resulting in personal injury.
 5. Jump-start vehicles on dry ground or concrete. Do not jump-start the machine on a steel floor, because the floor is always grounded.
 6. When starting from another machine, make sure the machines do not touch.
 7. Always connect the auxiliary battery positive (+) terminal too depleted battery positive (+) terminal first. Then connect auxiliary battery negative (-) terminal to the frame of the depleted battery machine second.
 8. Connect positive cable first when installing cables and disconnect the negative cable first when removing.
-



HAOA440L

Figure 10

IMPORTANT

The machine has a 12V (-) negative ground electrical system. Use the same capacity 12V booster batteries when jump-starting engine.

If the batteries are drained during starting procedures, jump-start engine using auxiliary or booster batteries according to the following procedure:

Connecting the Booster Batteries

1. Shut down engine of the machine on which booster batteries (c, Figure 11) are mounted.
2. Connect one end of red cable (a, Figure 11) to the positive (+) terminal of the machine batteries, and the other end to the positive (+) terminal of the booster battery (c, Figure 11).
3. Connect one end of black cable (b, Figure 11) to the negative (-) terminal of the booster battery, and then make ground connection to the upper frame of the machine (e, Figure 11) to be started with the other end of black (-) cable (b, Figure 11). When making the last connection to upper frame, be sure to connect the cable end as faraway from the machine batteries as possible. DO NOT CONNECT DIRECTLY TO THE NEGATIVE BATTERY TERMINAL.
4. Start the engine.

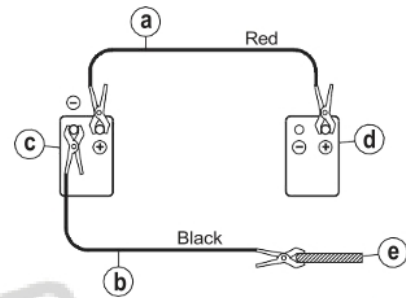

Figure 11

Disconnecting the Booster Batteries

1. Disconnect black negative (-) cable (b, Figure 11) from the machine frame first.
2. Disconnect the other end of black negative (-) cable (b, Figure 11) from the booster battery.
3. Disconnect red positive (+) cable (a, Figure 11) from the booster battery.
4. Disconnect red positive (+) cable (a, Figure 11) from the machine battery.

Hydraulic System Warm-up

WARNING

If a problem or abnormal operation occurs, immediately shut down engine. Allow excavator to reach normal operating temperature before starting work, especially in cold weather.

The correct operating temperature of the hydraulic oil is 50° - 80°C (120° - 175°F). Make sure to follow the procedures listed here for hydraulic fluid warm-up.

1. Run engine for approximately five minutes set at the middle of the speed range, without a load.

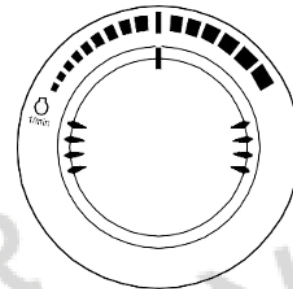

Figure 12

HAOB410L

2. Set safety lever (1, Figure 13) on "UNLOCK" position.

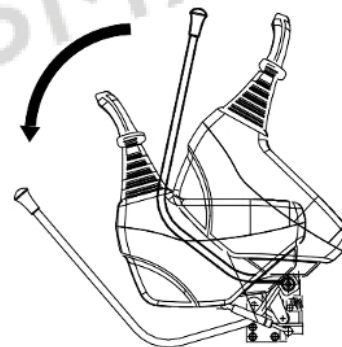

Figure 13

FG010085

3. Slowly cycle boom, arm and bucket cylinders about five times without a load to circulate the oil through the system. Do this for five minutes.
4. Check for clearance and fully raise the front attachment. Swing clockwise 3 revolutions. Swing counterclockwise 3 revolutions.
5. Travel forward and reverse at low speed for two revolutions of the drive sprocket.

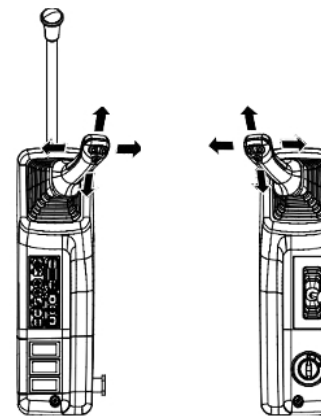

Figure 14

FG000521

Hydraulic System Warm-up – Cold Weather

1. Run engine at "LOW IDLE" (no load) for five minutes (Figure 15).

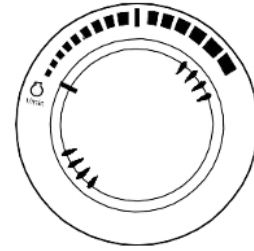

Figure 15

HAOB290L

2. Run engine for approximately five minutes set at the middle of the speed range, without a load (Figure 16).

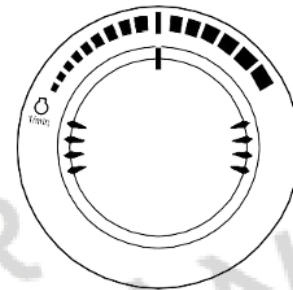

Figure 16

HAOB410L

3. Set safety lever (1, Figure 17) on "UNLOCK" position.

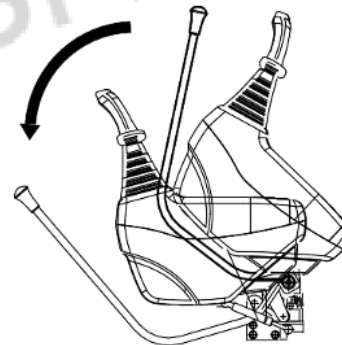

Figure 17

FG010085

4. Slowly cycle boom, arm and bucket cylinders about five times without a load to circulate the oil through the system. Do this for five minutes.

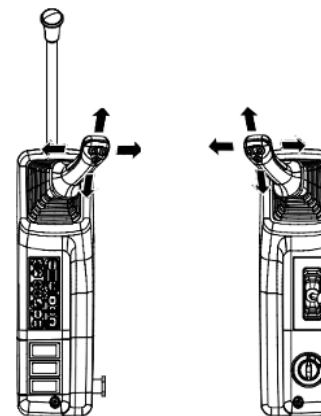
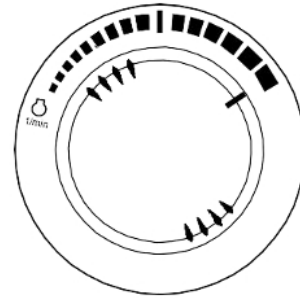

Figure 18

FG000521

5. Set engine speed control dial to "HIGH IDLE" (Figure 19).
6. Repeat Step 4 for five minutes. If working speeds continue to be slow, continue to operate, but use extreme caution because the machine function may be erratic.
7. Check for clearance and fully raise the front attachment. Slowly swing clockwise 3 revolutions. Slowly swing counterclockwise 3 revolutions.
8. Travel forward and reverse at low speed for two revolutions of the drive sprocket.



HAOB550L

Figure 19

Check and Confirmation After Engine Start

1. Instrument and Warning Light Confirmation

No.	Instrument Panel Light or Gauge	Indicator Reading
1	Engine Coolant Temperature Gauge	White
2	Fuel Gauge	White
3	Engine Oil Pressure Warning Light	OFF
4	Charging Warning Light	OFF
5	Air Cleaner Clogged Warning Light	OFF
7	Engine Coolant Temperature Warning Light	OFF
8	Fuel Level Warning Light	OFF

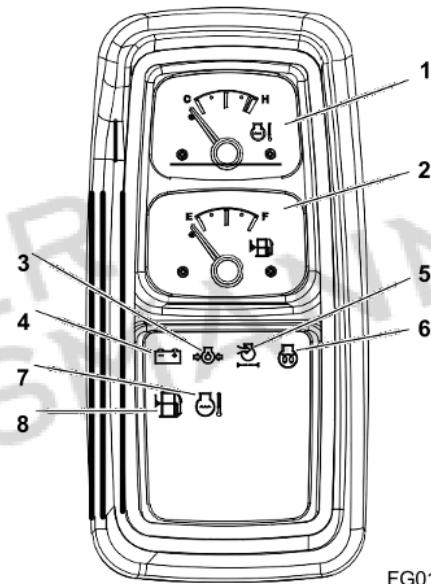

FG010201

Figure 20

2. Engine Operating Condition Confirmation

No color or light blue - Engine is running in good condition.

Black - Incomplete combustion. Check cause. White

or dark blue - Engine is burning engine oil.

NOTE: *If engine coolant temperature gauge pointer moves into the red zone, the engine coolant temperature warning light will turn "ON." Allow the engine to run at low idle speed until the temperature gauge registers in the white zone again. When the white zone is reached, allow the engine to idle for an additional three - five minutes before shutting down the engine. If not allowed to idle, heat surge may develop which will damage the engine. Allowing the engine to idle will dissipate heat. Check the coolant level, look for a loose fan belt, inspect for debris around radiator, and so on.*

Engine Shut Down

NOTE: Allow engine to idle for three - five minutes before shutting down the engine. If not allowed to idle, heat surge may develop which will damage the engine. Allowing the engine to idle will dissipate heat.

1. Park machine on firm, level ground.
2. Lower front end attachment to ground and make sure all operating controls are in "NEUTRAL."

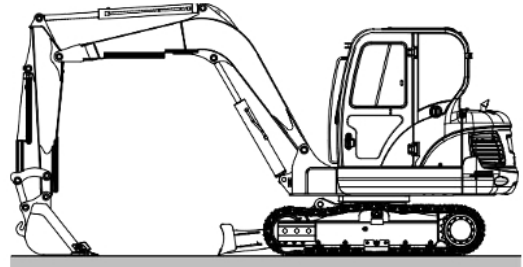

FG010086

Figure 21

3. Set safety lever on "LOCK" position (Figure 22).

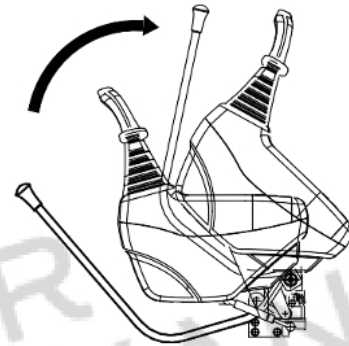

FG010050

Figure 22

4. Set engine speed control dial to "LOW IDLE" (Figure 23). Allow engine to idle for three - five minutes.

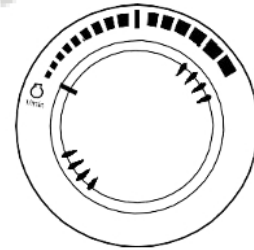

HAOB290L

Figure 23

5. Shut down engine by turning key to "O" (OFF) position (Figure 24).
6. Remove key from starter switch.

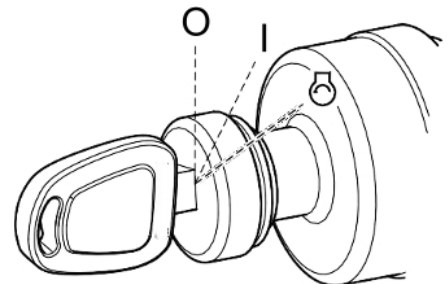

FG000390

Figure 24

Check and Confirmation After Stopping Engine

1. Repair excavator, if there are any coolant or oil leaks.
2. Inspect front attachment and under carriage for abnormal appearances. Correct any problems.
3. Fill fuel tank.
4. Get rid of any accumulated flammable materials such as leaves and paper etc. in engine compartment.
5. Clean all mud, etc. from undercarriage and tracks. Make sure that all steps and handholds are clean, and that operator's cabin is clean.



GÜNTER
GROSSMANN

SAFETY LEVER

WARNING

When stopping engine or leaving the operator's seat, "LOCK" the safety lever, otherwise, a serious accident may occur by accidental movement of travel and work levers.

Whenever leaving the operator's seat, make sure the engine is shut down and the safety lever is "LOCKED."

Especially, when adjusting the seat, control stands, or raising the front window, lower window, or ceiling cover, never forget to lock the safety lever in its "LOCKED" position.

Be careful not to move the operation lever when raising up or pushing down the safety lever.

The safety lever is designed to lock the working control levers so even if the working control levers are moved unintentionally, they will not work. However, the safety lever does not control the travel levers and boom swing pedal.

1. Pull safety lever up to allow left-hand control console to raise into the "LOCKED" position. Make sure that safety lever is "LOCKED" into the raised (up) position. When safety lever is in the "LOCKED" position, front attachment movement will be disabled even though a lever is moved.

NOTE: Lower bucket (front attachment) and blade to ground. Place all control levers in "NEUTRAL" and shut down engine.

2. Set safety lever on "RELEASE/UNLOCK" position, by pushing it down before starting work.

NOTE: When the engine is not running, but the safety lever is "RELEASED" and the starter key is tuned "ON," moving the joysticks may result in movement. The charged accumulator in the system will provide pilot pressure for control valve spool movement.

NOTE: If the front attachment moves when the safety lever is moved to the "RELEASE/UNLOCK" position and all levers and pedals are in "NEUTRAL," return the safety lever to "LOCK" position, shut down engine and contact your nearest Günter Grossmann dealer. There is a malfunction with the system.

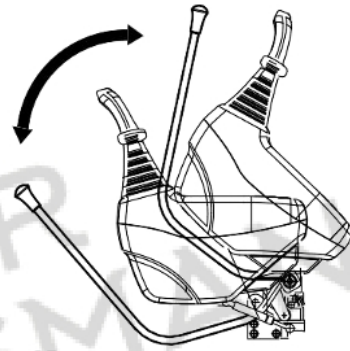

Figure 25

FG010087

TRAVEL

WARNING

1. Before operating the travel levers, make sure that you know in which direction the machine is pointing. Look at the end of the track assemblies. If the drive motors are visible while sitting in the operator's seat, you are looking at the back end of the track assembly (therefore, you are looking backwards). In this case, the response of the travel levers will be the reverse of normal operation.
 2. Before moving, make sure there are no personnel in the way or on the machine. Sound the horn to alert workers that you are about to move the machine.
 3. Be sure the path is clear during travel.
 4. Use extreme caution when reversing travel. Be sure there is a clear path behind the machine.
 5. Make sure to operate the travel control levers smoothly to avoid sudden starts or stops.
 6. Before leaving the operator's seat, make sure to lock out all control systems and shut down the engine to avoid accidental activation.
-

Travel Speed Control

WARNING

Do not change the travel mode while traveling. Always use speed mode "O" when traveling down a slope. It is very dangerous to change to speed modes indicated "I" or "II" while going down a slope. Only change travel mode after coming to a complete stop.

Two travel speed ranges can be selected by using the travel speed selector switch on the control panel (Figure 26).

"O" (LOW) - In this position low travel speed and a higher torque are selected.

"I" (HIGH) - In this position high travel speed and a lower torque are selected.

An example is if the machine is traveling on a flat, solid surface, the higher speed range would be used. When a slope is encountered, the speed drops and the travel circuit hydraulic pressure rises, causing the control circuit to shift to the higher torque, lower speed range.

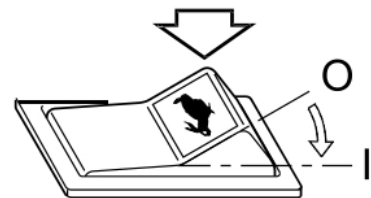
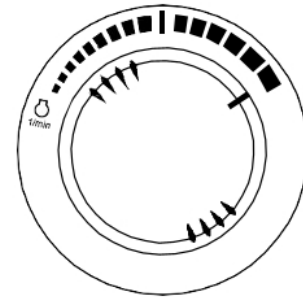

Figure 26

HDO20221

General Travel Instructions

1. Set engine speed control dial (Figure 27) on desired speed.



HAOB550L

Figure 27

2. Set safety lever on "UNLOCK" position, and folding the front, raise it 40 - 50 cm (16 - 20 in) aboveground. See Figure 28.

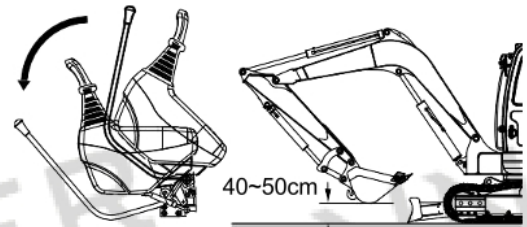

FG012351

Figure 28

3. To travel straight (Figure 29), push both travel control levers/pedals fully forward or backwards. The farther the levers/pedals are pressed, the faster the travel speed.

NOTE: "X" is the sprocket end of the track.

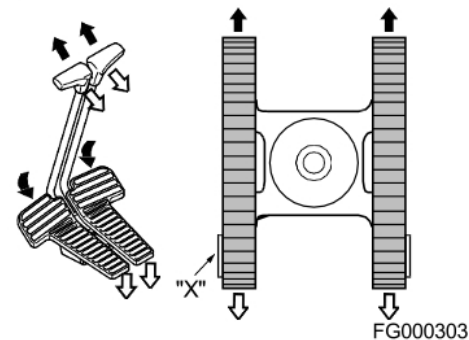

FG000303

Figure 29

4. Pivot turns (Figure 30) are made by rotating only one track forward or backward. The machine will pivot on the nonmoving track.

NOTE: "X" is the sprocket end of the track.

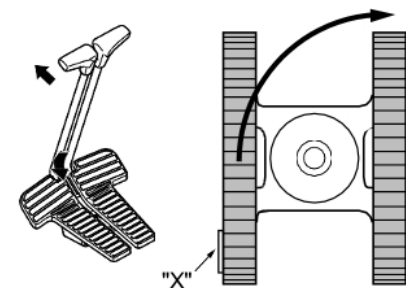

FG000304

Figure 30

5. Spin turns (Figure 30) are made by rotating one track forward and one track backward. The machine will spin around its center point, thus counterrotating.

NOTE: "X" is the sprocket end of the track.

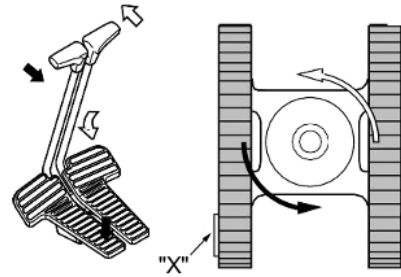

Figure 31

FG000305

6. Stopping travel (Figure 31) - Returning travel levers to "NEUTRAL" position will automatically apply brakes and stop excavator.

NOTE: "X" is the sprocket end of the track.

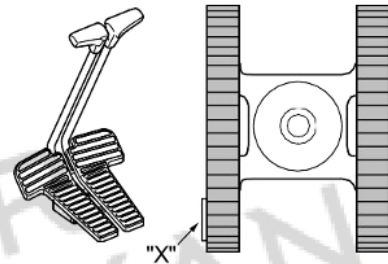

Figure 32

FG000306

Caution on Traveling

1. When possible, travel on firm, level ground. Avoid sudden movements and sharp turns.
2. When traveling on rough ground, travel at a slow speed [1.0 - 1.5 km/h (0.62 - 0.93 MPH)]. Reduced engine speed, to avoid shock loading the equipment. Be careful that an excessive force is not added to equipment by touching or climbing on rocks.



Figure 33

FG010118

3. On rough, frozen or uneven terrain, travel slowly.

! **WARNING**

When traveling, keep bucket from 20 - 30 cm (8 - 12 in) aboveground.

Do not travel backward on a slope.

Never turn or travel crosswise on a slope.

Choose a safe alternate route before climbing a slope.

If excavator starts to slip or becomes unstable, lower the bucket immediately into the ground, using it as a brake.

Avoid working on slopes, because there is a danger of overturning by becoming unbalance while swinging and performing front attachment operations.

It is very dangerous to swing towards bottom of slope with a loaded bucket.

In unavoidable cases level the slope with fill soil, to make the vehicle as horizontal as possible. See Figure 35.

Do not travel on slopes more than 30° because of turnover danger.

4. Travel straight up or downslopes, never diagonally across the slope. See Figure 35 and Figure 35. Extend the arm and lower the boom to keep the bucket about 20 - 30 cm (8 - 12 in) off the ground. If the machine starts to slide or becomes unstable, lower the bucket to regain control. If the engine stalls, lower the bucket, make sure that all controls are in the neutral position and restart the engine.

NOTE: Even though engine stops on a slope, do not operate swing control. The hydraulic accumulators may cause the unit to swing.

NOTE: Do not open or close operator's door on a slope. Make sure door is latched.

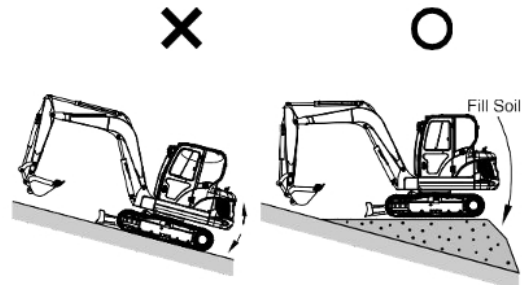

Figure 34

FG010675

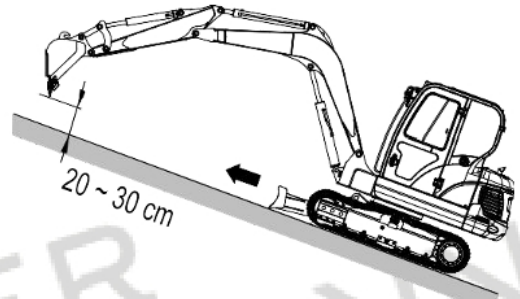

Figure 34

FG010090

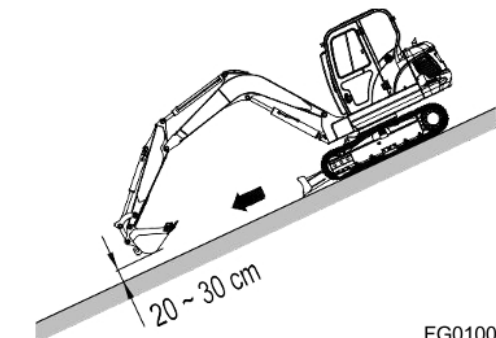

Figure 35

FG010091

- If dirt or mud builds up in the track frame, raise each track and rotate and clean that track.



CAUTION

When using the boom and arm to lift any portion of the machine, roll the bucket until the round base is against the ground. The angle of the arm to the boom should be at 90° .

Make sure that material buildup has been cleared. See Figure 36 and Figure 34.

- The excavator can travel in water that comes up to center of upper carriage rollers. Make sure that footing is solid so the machine will not sink. See "Working in Water" on page 3-28.

NOTE: *If the machine is submerged to the point that water or mud gets into the swing bearing or center joint, stop machine operation. Remove machine from the submerged location to firm, dry ground. Do not operate until proper inspection and maintenance have been completed. Refer to the Shop Manual or contact your distributor.*

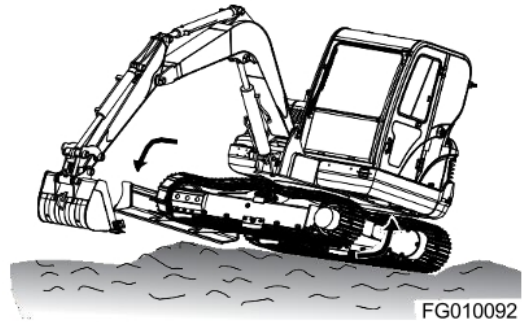

Figure 36

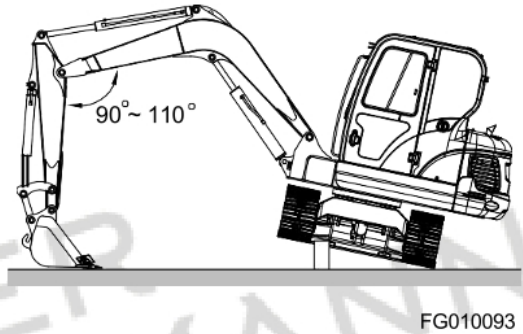

Figure 37

OPERATING INSTRUCTIONS

Engine Speed Control

Engine speed can be manually adjusted using the engine speed control dial, Increase engine speed by rotating the control knob clockwise. Decrease engine speed by rotating the control knob counterclockwise.

IMPORTANT

The engine speed control system has been set at the factory and should not require adjustment as part of routine maintenance.

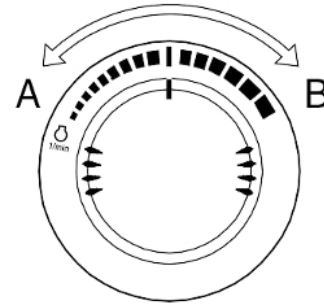

Figure 38

HAOA690L

Work Levers (Joysticks) (ISO Style)

WARNING

Check surrounding area before swinging. When operating a lever while in auto idle, do it carefully, because the engine speed will increase rapidly.

NOTE: When starting work, move work levers (joysticks) slowly and check movement of swing and front attachment.

This equipment is manufactured using the lever configuration described in ISO standards. Do not change valving, hoses, etc., that would change this standard. The boom, arm and bucket movements and swing direction of work levers (joysticks) are as follows:

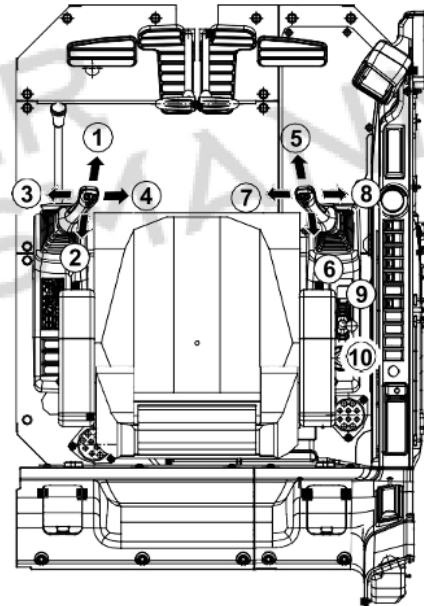

FG010094

Figure 39

Left-hand Work Lever (Joystick) (Figure 39 and Figure 40)

1. Arm dump
2. Arm crowd
3. Left swing
4. Right swing

NOTE: The swing brake is spring applied and hydraulically released. It is always engaged when the work lever (joystick) is in "NEUTRAL" or the engine is shut down.

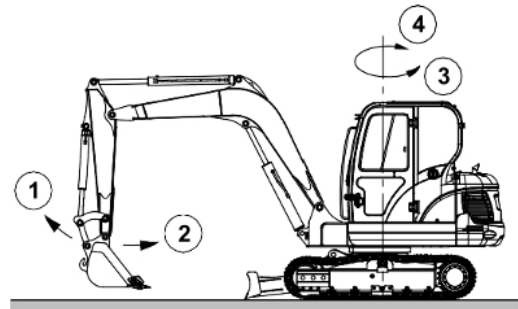

FG010095

Figure 40

NOTE: The following is not a mechanical malfunction but a proper phenomenon of the excavator. When operating the arm, it may stop momentarily. When the arm is operated, the weight of the arm may cause it to move faster than the amount of oil being supplied.

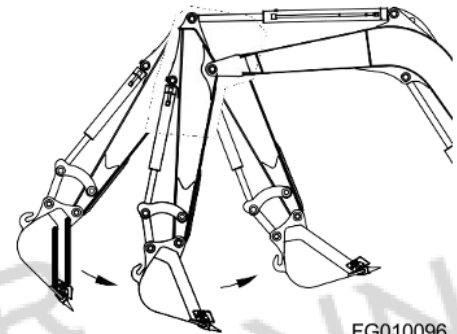

FG010096

Figure 41

Right-hand Work Lever (Joystick) (Figure 39 and Figure 42)

5. Boom down
6. Boom up
7. Bucket crowd
8. Bucket dump

NOTE: Even after stopping the engine, the front can be lowered to the ground by operating work lever (joystick), by setting safety lever on "UNLOCK" position and turning starter switch "ON."

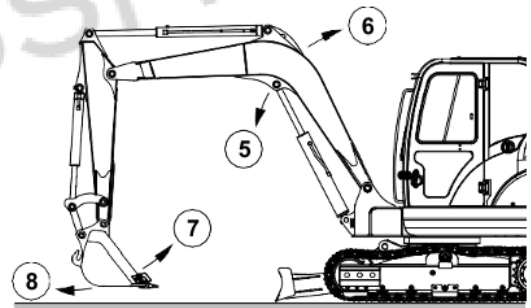

FG010097

Figure 42

Dozer Lever (Optional)

9. Dozer down
10. Dozer up

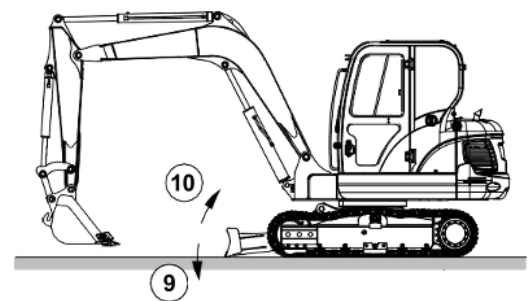

FG010098

Figure 43

Change Machine Control Pattern by Select Valve (If Equipped)

WARNING

Check surrounding area before swinging. When operating a lever while in auto idle, do it carefully, because the engine speed will increase rapidly.

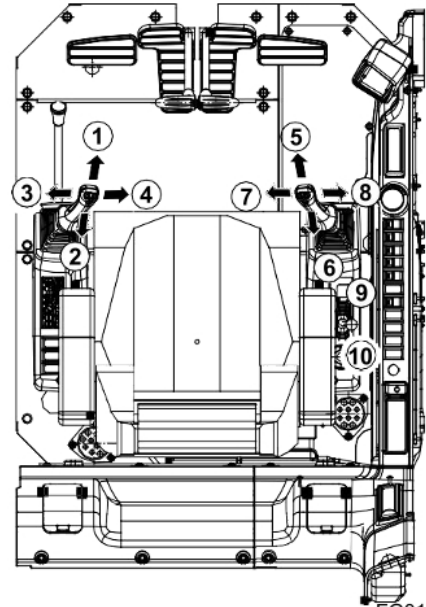

Figure 44

FG010094



GÜNTER
GROSSMANN

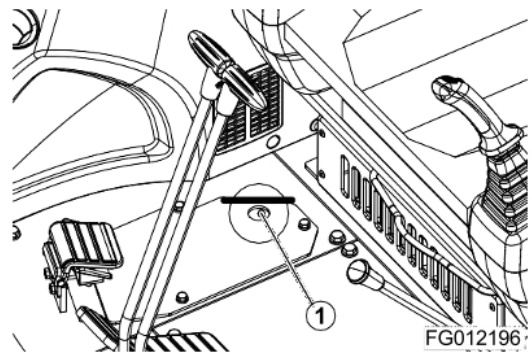

Figure 46

FG012196

OPERATING PRECAUTIONS

WARNING

Do not rest your feet on the travel pedals during normal machine operation. Unexpected machine travel may occur in this situation.

1. Before starting work, investigate terrain and soil condition. Level ground and drain area if necessary.
2. Install window guards when working where there is a possibility of falling rocks or other objects.

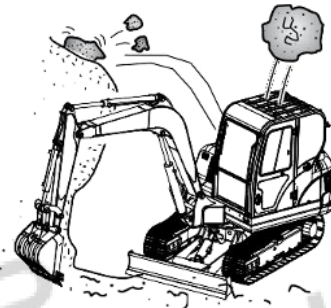

Figure 50

FG010099

3. Check strength of supported structures in advance before working on them. If insufficient, reinforce it. If any doubt exists about structural strength, refuse to operate unit.
4. It is possible that boom, arm or bucket may come into contact with the upper or lower structure of the machine. There are digging conditions which could allow this to happen.

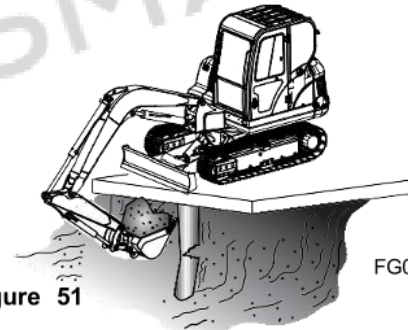

Figure 51

FG010100

5. Do not continually "bottom out" the hydraulic cylinders. Machine damage may occur if the cylinders are fully extended or retracted, example: arm cylinder fully retracted and the bucket cylinder is extended to rotate the bucket into the ground.

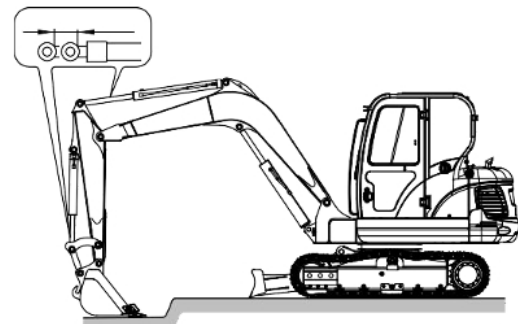

Figure 52

FG010101



GÜNTER
GROSSMANN

6. Do not use machine travel or swing when the bucket is in the ground to provide additional breakout force. See Figure 53.

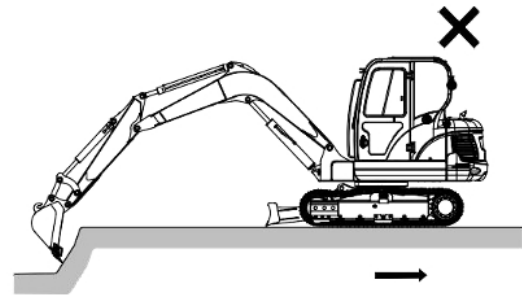

FG010102

Figure 53

7. Do not use machine weight to provide additional breakout force. See Figure 54.
8. When working on soft or muddy ground, make sure that machine is not sinking.

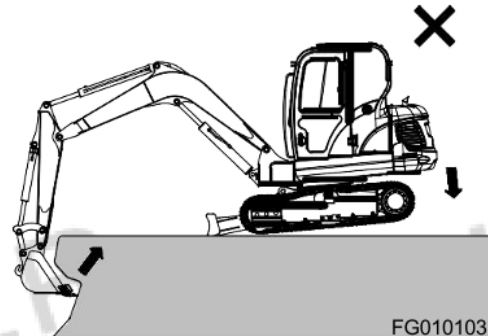

FG010103

Figure 54

9. When working close to the excavated edge, make sure that ground the machine is sitting on is solid. Keep the travel motors (1, Figure 55) to the rear. See Figure 55.

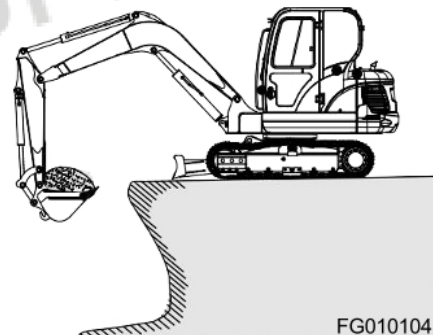

FG010104

Figure 55

10. Do not excavate underneath the machine. See Figure 56.

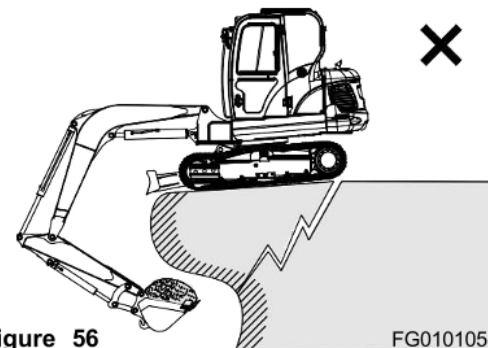

FG010105

Figure 56

11. Make sure there is adequate clearance from overhead electrical supply lines. See Figure 57.

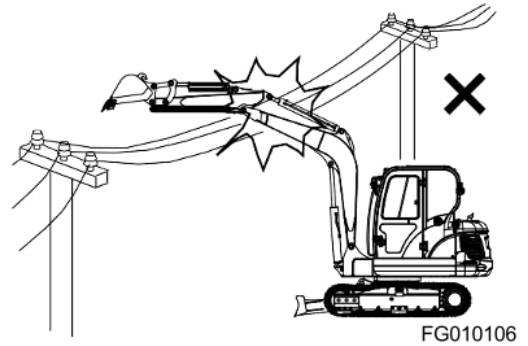

Figure 57

12. If the excavation is in an underground location or in a building, make sure there is adequate overhead clearance and that there is adequate ventilation. See Figure 58.

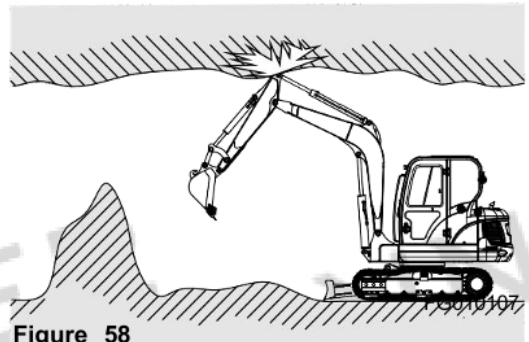

Figure 58

13. Do not use the bucket as a hammer or ramming device. This is dangerous and causes damage to the front attachment. See Figure 59.

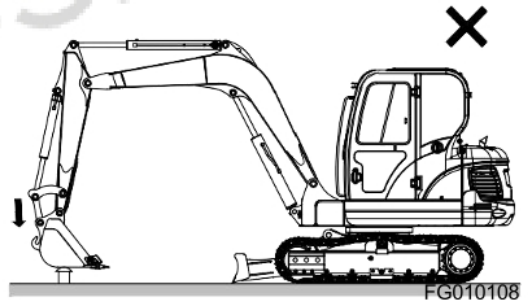

Figure 59

14. Do not dig with the excavator tracks raised. This can result in structural and mechanical failures.

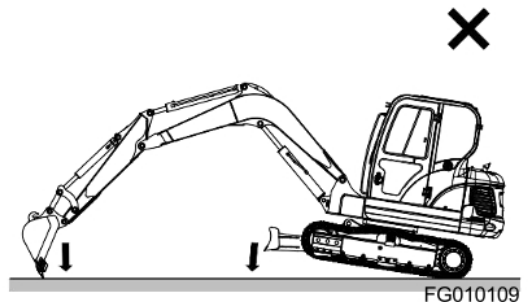

Figure 60

15. Do not operate travel lever quickly when traveling in high range.
 - Avoid sudden starts.
 - When traveling in one direction come to a complete stop before reversing directions. Do not rock excavator back and forth with levers.
 - Avoid sudden stops. Return levers to neutral by hand. Do not let them snap back to neutral on their own.
16. If the optional long fronts or attachments or heavy-duty front end attachments are used, the machine balance will be altered. Follow these additional operating precautions.

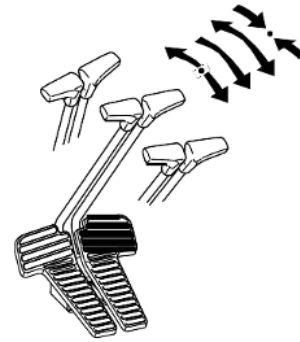

Figure 61

FG000213



WARNING

Do not travel downhill with the front end attachments raised.

Do not travel across slopes; travel straight up or downslope.

Use extreme caution when swinging the upper frame when positioned on a slope.

Allow extra swing stopping room. The additional momentum generated by the longer or heavier front end equipment will increase the amount of time needed to stop the swing motion.

Make sure that all optional equipment has been authorized and installed properly.

17. Do not move dirt or objects by swinging the excavator into them. This can result in structural and mechanical failures.

Working in Water

IMPORTANT

When working in water, do not exceed a slope of more than 15°. If the slope is over 15°, the rear part of the upper structure will be immersed in water, resulting in radiator fan and engine ECU damage.

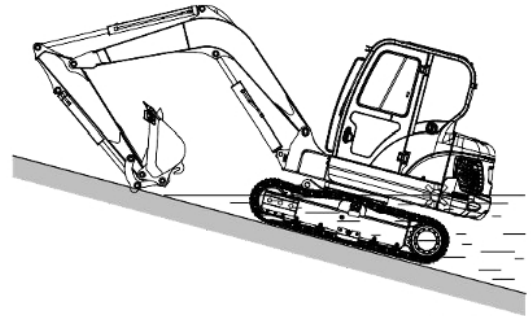

FG010522

Figure 62

When working in water, do not operate over center of upper roller (1, Figure 63).

If swing bearing gets wet, immediately grease it until all old grease is purged from bearing.

If water gets into swing gear housing, drain water immediately by removing lower inspection cover. Apply new grease.

After working in water, purge old grease on bucket pins.

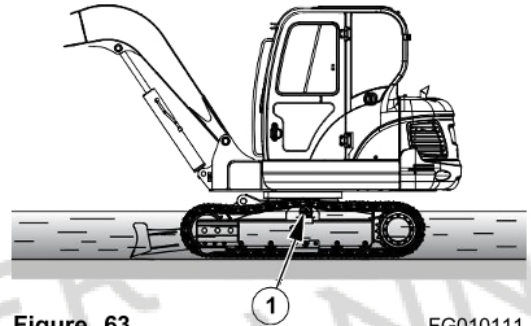

Figure 63

FG010111



GÜNTER
GROSSMANN



WARNING

Park machine on firm, level ground. Avoid parking on slopes. If excavator must be parked on a slope, block tracks and place bucket teeth in ground. See Figure 64. If you touch the operation lever unintentionally, it may create a serious accident. The safety lock lever must be set to the "LOCKED" position.

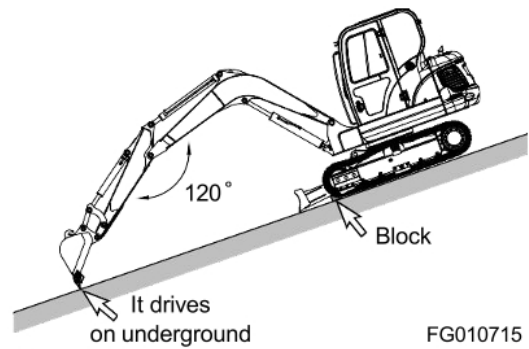

Figure 64

FG010715

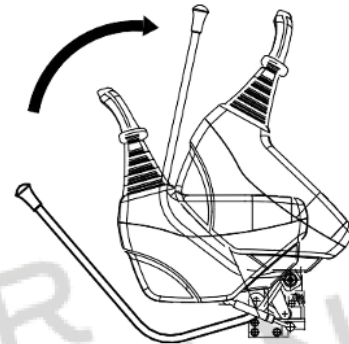

Figure 65

FG010050

1. Park machine on firm, level ground. Lower bucket to ground as shown in Figure 66.

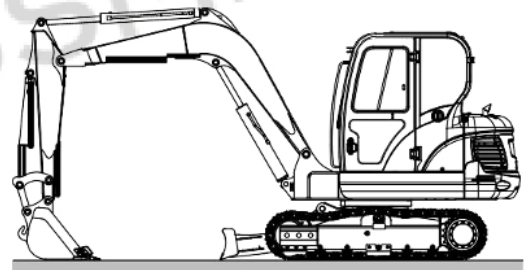

Figure 66

FG010086

2. Set engine speed control dial on "LOW IDLE."

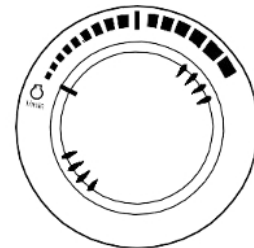
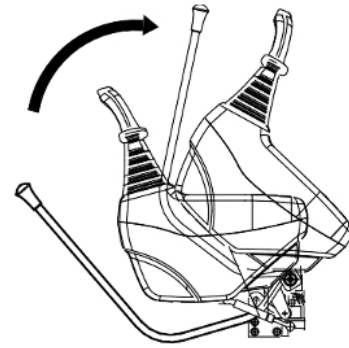

Figure 67

HAOB290L

3. If you touch the operation lever unintentionally, it may create a serious accident. Before leaving operator's seat, set safety lever on "LOCK" position.



FG010050

Figure 68

TOWING PROCEDURE

WARNING

Never use a damaged wire rope or chain. They could brake and cause a serious accident.

Always wear gloves when handling a chain or wire rope.

When towing excavator use a wire rope or chain capable of handling the load.

Attach chain or wire rope to track frame as shown in Figure 69

Insert protective material such as thick cloths between track frame and wire rope to prevent the wire rope from being damage.

IMPORTANT

Use shackle hook on track frame to only haul objects that weigh less than 7 metric tons (7.71 U.S. Tons). Never use it to haul objects over 7 metric tons (7.71 U.S. Tons).

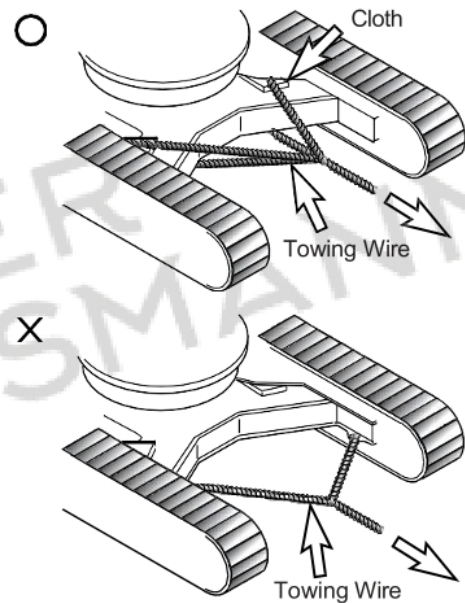

FG014871

Figure 69

HYDRAULIC BREAKER

IMPORTANT

If a hydraulic breaker and piping is installed without *Günter Grossmann*'s authorization, it may create a serious malfunction which will not be covered under the excavator warranty.

Selection of Hydraulic Breaker

If a hydraulic breaker is installed, consider equipment's stability and suitability for such modification. Also, consider hydraulic oil pressure and quantity. When selecting a hydraulic breaker consult with a *Günter Grossmann* distributor or sales agency.

Hydraulic Hoses and Tubing for Breaker

1. When installing hydraulic breaker, assemble according to drawings provided with kit.
2. If breaker is taken off excavator, be sure to plug and cap all hoses and tubing to prevent contamination from entering hydraulic system.
3. Plug and cap all connectors and fittings on breaker to prevent contamination.
4. Check all hydraulic connections for signs of leaks or loose components before starting operation.

Hydraulic Breaker Operation

NOTE: *Hydraulic pressure and flow settings may need to be changed. Refer to the Maintenance Section of this manual for further information.*

1. Make sure to read and understand the breaker user's manual.
2. Inspect all mechanical and hydraulic connections.

- Do not use the breaker as a hammer. See Figure 70. Do not drop breaker from extreme heights.

The breaker is fairly heavy and drops fast. Do not drop breaker from extreme heights or damage to upper structure may result.

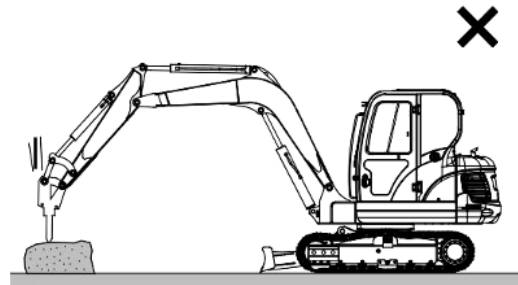

FG010113

Figure 70

- Do not operate the breaker with the boom or arm cylinders fully extended (bottomed out). See Figure 71.

Leave over 100 mm (4 in) of clearance between rod end of cylinder and cylinder head. This will help prevent damage to cylinders during breaker operation.

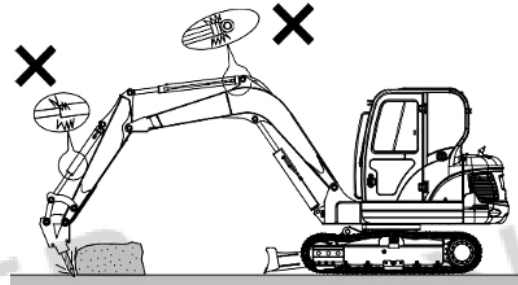

FG010114

Figure 71

- Do not use the breaker if the hydraulic hoses vibrate excessively. See Figure 72. Check the breaker's hydraulic accumulator (1) for damage and repair as required. If excavator is operated under this condition, structural and hydraulic components can be damaged.

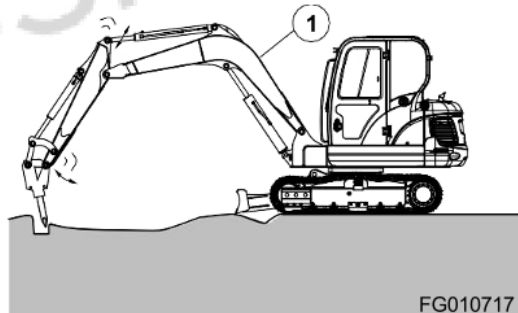

FG010717

Figure 72

- Do not curl the breaker tool tip into the arm or boom when traveling or parking the excavator. See Figure 73.

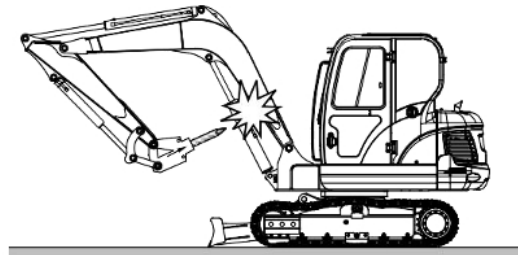

FG010116

Figure 73

- Do not allow the breaker body to go into water if not equipped for underwater operation. The breaker seal can be damaged and allow rust, foreign material or water to enter the hydraulic system and cause damage. Only insert the breaker tool into water. See Figure 74.

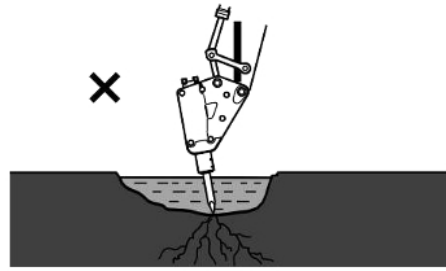

HAOB970L

Figure 74

- Never lift or tow something with a breaker. See Figure 75.

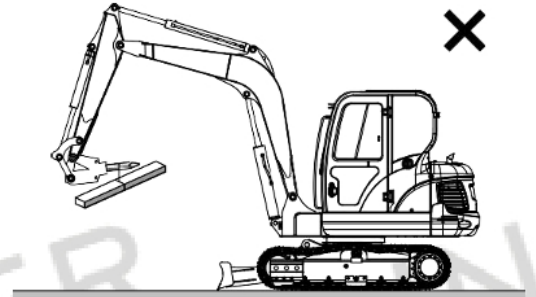

FG010117

Figure 75

- Operate the breaker only to the front and rear of the excavator. Do not use the breaker to either side of the excavator. Do not swing the breaker from side to side when operating it. See Figure 76.



WARNING

Operating a breaker with the upper body turned 90° to the tracks can result in tipping over the machine or reduction in service life.

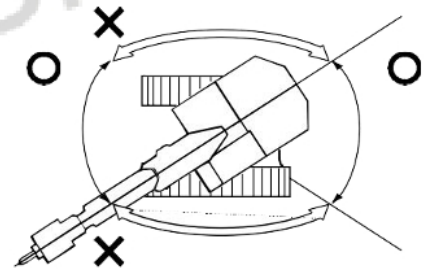

HAOB990L

Figure 76

To Activate Breaker

- Set breaker selector switch to "II" (BREAKER) position.
- Press lower button on top of right-hand work lever(joystick) to activate hydraulic breaker.
- Release lower button on top of right-hand work lever (joystick) to deactivate hydraulic breaker.

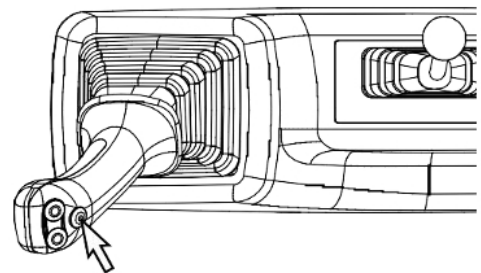

FG010519

Figure 77

Hydraulic Oil and Filter Service Intervals

When using a hydraulic breaker, the viscosity breakdown and contamination of hydraulic oil is faster because the work condition is more severe than during normal digging work. To prevent the hydraulic components (especially pump) from having a shortened life cycle, replace the hydraulic oil and main hydraulic oil return filter using the following schedule.

Attachment	Operation Rate	Hydraulic Oil	Filter
Bucket Work	100%	2,000 Hours	250 Hours (First Replacement) 1,000 Hours (After First Replacement)
Hydraulic Breaker Work	100%	500 Hours	100 Hours

* These service intervals only apply, when a genuine *Günter Grossmann* oil and filter are used. If any other brands are used, the guaranteed changed interval should be reduced in half.

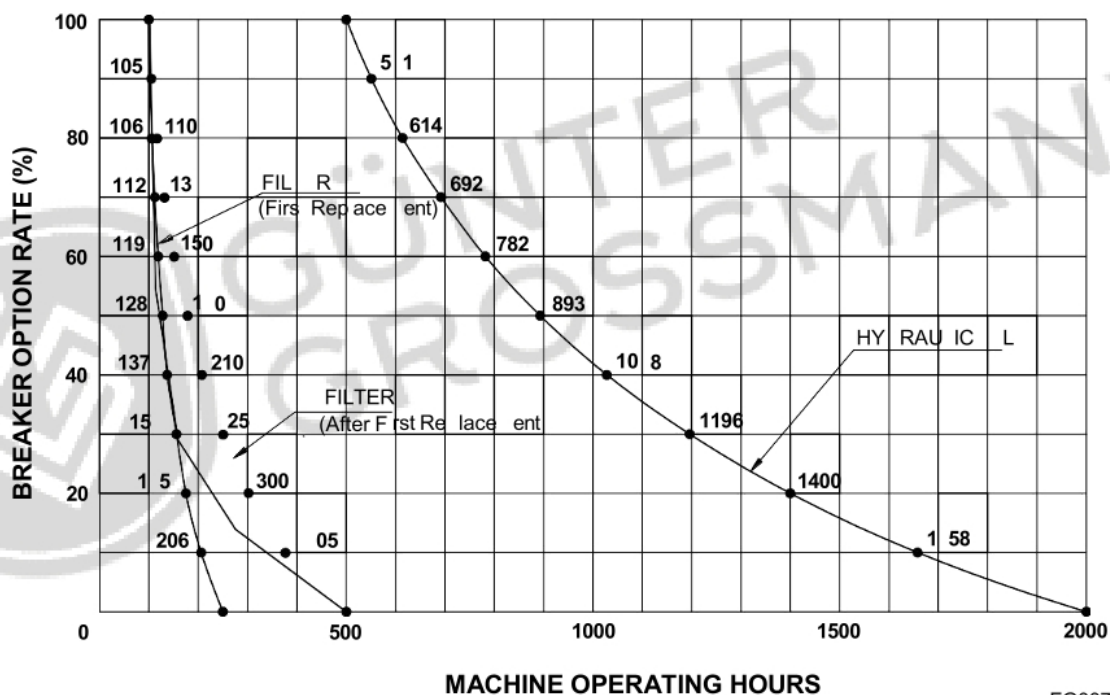

Figure 78

FG007618

NOTE: The replacement intervals of hydraulic oil and filter depend upon the amount of time the hydraulic breaker is being used. These intervals should be followed as opposed to regularly scheduled maintenance.

Tilting Operation Using the Pedal

1. Pushing down on the top end of the PTO pedal, operates front attachment.
2. Releasing the PTO pedal, stops front attachment.

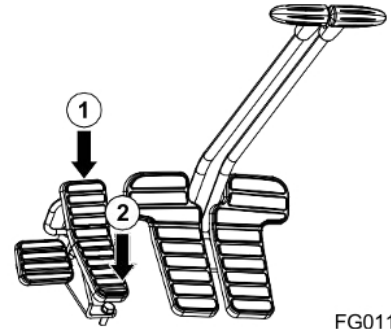

FG011241

Figure 79

Locking the PTO Pedal

When the operation is not needed, the pedal can be locked by using the prop rod (1) locking device.

Locking is completed when the top end of the prop (2) is positioned into pedal hole (3).

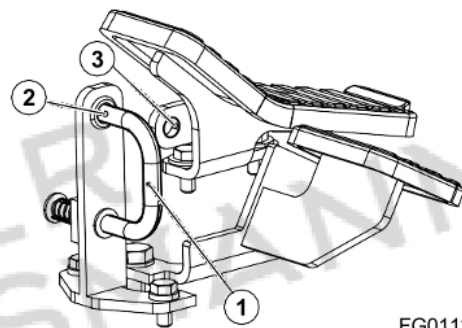

FG011243

Figure 80

- A. Position for "UNLOCKING."
- B. Position for "LOCKING."

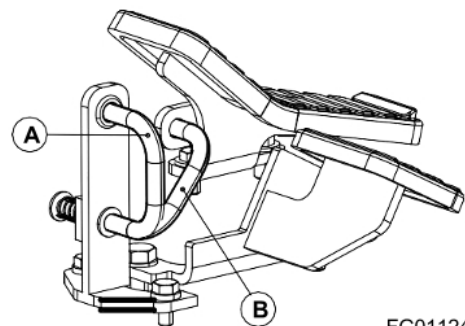

FG011244

Figure 81



Blade Control Lever Operation

The blade control lever, located on the right-hand side of the driver's seat, controls the operation of the blade. When the lever is released, it goes to the NEUTRAL position and the blade stops immediately.

1. Pulling lever back "RAISES" dozer blade.
2. Pushing lever forward "LOWERS" dozer blade.

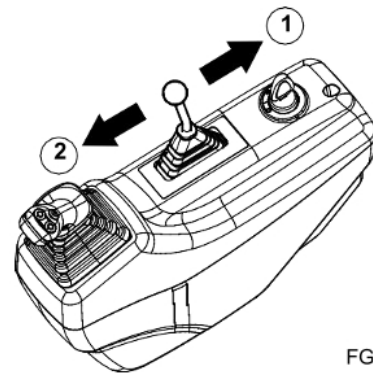

FG010524

Figure 84

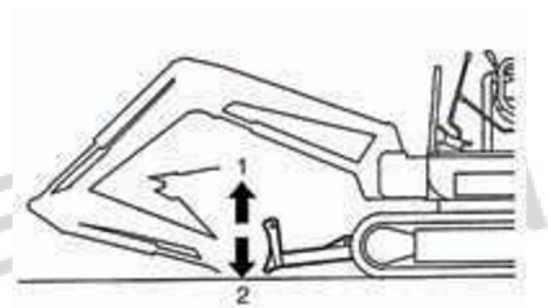

FG007604

Figure 85

Precautions for Blade Use

The blade control lever, located on the right-hand side of the driver's seat, controls the operation of the blade. When the lever is released, it goes to the NEUTRAL position and the blade stops immediately.

1. Use the blade only for earth moving. Do not use the blade to dig; this can damage the blade or the track system.
2. Do not apply a large or unbalanced, off-center load to the blade: this can damage the blade or the track system.
3. Do not strike anything with the blade while traveling. This can damage the blade or track system.
4. When using the blade to jack up the machine, make sure that ground is even and will give good support and that blade contacts the ground evenly.
5. When the blade is positioned in front of the machine, while excavating or bringing the front attachment in, be careful not to strike and damage the blade.

OPERATING TECHNIQUES

Lifting

IMPORTANT

There may be local or government regulations, about the use of excavators for the lifting of heavy loads. Always contact your local and government agencies in regards to these regulations.

To prevent injury, do not exceed the rated load capacity of the machine. If the machine is not on level ground, load capacities will vary.

Short slings will prevent excessive load swing.

Use the lifting eye on the bucket that is provided to lift objects.

Always try to maintain the lifting eye (Figure 86) straight below the centerline of the arm and bucket pin. In this manner the weight of the load is being primarily held only by the pin, and not by the bucket cylinder, link, and link pins.

When a lifting eye is used, the sling/lifting device must be fastened to the eye in a manner that will not allow it to come loose.

The most stable position is over the corner of the machine.

For best stability, carry a load as close to the ground and machine as possible.

Lift capacity decreases as the distance from the machine swing centerline is increased.

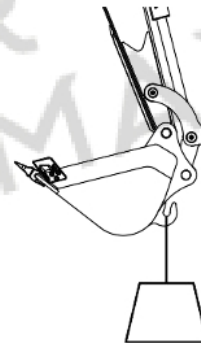

Figure 86

FG010738

Lifting Unknown Weight

When loads are not accurately known are to be lifted, the person responsible for the job shall ascertain that weight of the load does not exceed the machine LOAD RATING CHART at the radius at which it is to be lifted.

It is recommended that you feel your way into any lift as a precaution against tip over. One method is to position the boom at 90° over the side of the machine. Slowly lift the load until it clears the ground. A lift over the side is the most unstable, and as the load is swung into the front zone of the excavator it will become more stable. **DO NOT INCREASE SWING RADIUS AFTER THE LOAD IS LIFTED.**



DANGER

If a load is picked up from the front zone and swung into the side zone, a tip over could result causing a deadly or fatal injury.

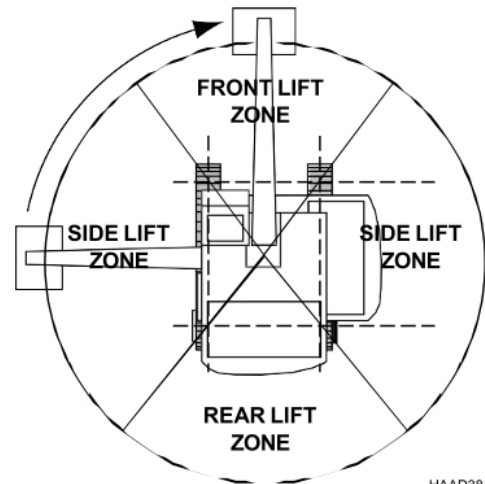

HAAD3842

Figure 87

Lifting Known Weight

The load chart is the governing factor when lifting known weights. It is recommended that you feel your way into any lift as a precaution against tip over. Whenever possible, lift and swing payloads between the front idler area.

Pick and Carry

The machine can pick and carry payloads without added labor. We recommend when traveling with a suspended payload, you evaluate the prevailing conditions and determine the safety precautions required in each case. The following factors must be considered before attempting to pick and carry a load.

Align the boom with the forward direction of machine travel. Maintain this boom position when turning the machine. Turn only when necessary, at the slowest speed, and at a wide turning radius.

1. Use the shortest lifting radius distance possible.
2. Keep the load as close to the ground as conditions will permit.
3. Provide tag lines to prevent load from pendulating. Pendulating can cause a change in radius. A change in radius could exceed the load chart rating or cause a tip over condition.
4. Govern travel speed to suit conditions.
5. Avoid sudden starts and stops.

OPERATION UNDER UNUSUAL CONDITIONS

NOTE: See "Maintenance in Special Conditions" on page 4-66 for other recommendations.

Operation In Extreme Cold

If machine is to be operated in extreme cold weather temperatures, certain precautions must be taken to assure continued normal operation. The following paragraphs detail checks to be made to be certain the machine is capable of operating at these temperatures.

1. Check the cooling system for correct antifreeze solution for lowest temperature expected. Carefully inspect cooling system and correct or report any leaks.
2. Keep batteries fully charged to prevent freezing. If water is added to batteries, run engine at least one hour to mix electrolyte solution.
3. Keep engine in best possible mechanical condition to assure easy starting and good performance during adverse weather.
4. Use engine oil of the proper specifications for the expected temperatures. Refer to the "Lubrication Specifications" of the engine manual for details.
5. Keep fuel tank full at all times. Drain condensation from tank before and after operation. Drain and service fuel filter. To eliminate clogging of fuel filters because of wax crystal formation in the fuel, be sure that fuel used has a cloud point specification below the lowest expected temperature.
6. Lubricate entire machine according to "Periodic Service Table and Chart" Section 4, in this manual or lubrication chart on machine.
7. Start engine and allow it to reach normal operating temperature before applying load.
 - A. If mud and ice collects and freezes on any of the moving parts while machine is idle, apply heat to thaw the frozen material before attempting to operate machine.
 - B. Operate hydraulic units with care until they have reached a temperature to enable them to operate normally.
 - C. Check all machine controls and/or functions to be sure they are operating correctly.
8. An extra outer air filter should be kept in the operator's cabin to replace element that could become iced and cause restricted airflow to engine.

9. If cold weather starting aid must be used, see "Engine Starting" COLD WEATHER START portion of this manual.
10. Clean off all mud, snow and ice to prevent freezing. Cover machine with tarpaulin if possible, keep ends of tarpaulin from freezing to ground.

Operation in Extreme Heat

Continuous operation of the machine in high temperatures may cause the machine to overheat. Monitor engine and transmission temperatures and stop machine for a cooling off period whenever necessary.

1. Make frequent inspections and services of the fan and radiator. Check coolant level in radiator. Check grills and radiator fins for accumulation of dust, sand and insects which could block the cooling passages.
 - A. Formation of scale and rust in cooling system occurs more rapidly in extremely high temperatures. Change antifreeze each year to keep corrosion inhibitor at full strength.
 - B. If necessary, flush cooling system periodically to keep passage clear. Avoid use of water with a high alkali content which increases scale and rust formation.
2. Check level of battery electrolyte daily. Keep electrolyte above plates to prevent damage to batteries. Use a slightly weaker electrolyte solution in hot climates. Dilute 1.28 specific gravity electrolyte as issued to 1.20 - 1.24 specific gravity readings at full charge. Recharge batteries whenever they reach a 1.16 specific gravity reading. Batteries self-discharge at a higher rate if left standing for long periods at high temperature. If machine is to stand for several days, remove batteries and store in a cool place.



WARNING

Do not store acid type storage batteries near stacks of tires; the acid fumes have a harmful affect on rubber.

3. Service fuel system as directed in "Engine Fuel System" Section 5, of this manual. Check for water content before filling fuel tank. High temperatures and cooling off cause condensation in storage drums.
4. Lubricate as specified in "Periodic Service Chart and Table" Section 4, in this manual or Lubrication Decal on the machine.

5. Do not park machine in sun for long periods of time. When practical park machine under cover to protect it from sun, dirt and dust.
 - A. Cover inactive machine with tarpaulin if no suitable shelter is available. Protect engine compartment, transmission and hydraulics from entrance of dust.
 - B. In hot, damp, climates corrosive action will occur on all parts of the machine and will be accelerated during the rainy season. Rust and paint blisters will appear on metal surfaces and fungus growth on other surfaces.
 - C. Protect all unfinished, exposed surfaces with a film of preservative lubricating oil. Protect cables and terminals with ignition insulation compound. Apply paint or suitable rust preventive to damaged surfaces to protect them from rust and corrosion.

Operation in Dusty or Sandy Areas

Operation of the machine can cause dust in almost any area. However, when in predominantly dusty or sandy areas, additional precautions must be taken.

1. Keep cooling system fins and cooling areas clean. Blow out with compressed air, if possible, as often as necessary.



WARNING

Wear goggles when using compressed air.

2. Use care when servicing fuel system to prevent dust and sand from entering the tank.
3. Service the air cleaner at frequent intervals, check air restriction indicator daily and keep dust cup and dust valve clean. Prevent dust and sand from entering engine parts and compartments as much as possible.
4. Lubricate and perform services outlined on current lubrication chart on machine and "Lubrication Chart and Table" Section 4. Clean all lubrication fittings before applying lubricant. Sand mixed with lubricant becomes very abrasive and speeds wear on parts.
5. Protect machine from dust and sand as much as possible. Park machine under cover or protect with tarpaulin to keep dust and sand from damaging unit.

Operation in Rainy or Humid Conditions

Operation under rainy conditions is similar to that as in extreme heat procedures listed previously.

1. Keep all exposed surfaces coated with preservative lubricating oil. Pay particular attention to damaged or unpainted surfaces. Cover all paint cracks and chip marks as soon as possible to prevent corrosive effects.

Operation in Salt Water Areas

The corrosive effect of salt water and salt water spray is very extensive. When operating in salt water areas, observe the following precautions.

1. When exposed to salt water, dry machine thoroughly and rinse with fresh water as soon as possible.
2. Keep all exposed surfaces coated with preservative lubricating oil. Pay particular attention to damaged paint surfaces.
3. Keep all painted surfaces in good repair.
4. Lubricate machine as prescribed on lubrication chart on machine or "Periodic Service Table and Chart" Section 4, in this manual. Shorten lubricating intervals for parts subject to exposure to salt water, if found necessary.

Operation at High Altitudes

Normally, operation of machine at high altitudes will be as outlined in extreme cold. Before operating at high altitudes, engine fuel and air mixture may have to be adjusted according to appropriate engine manual.

1. Check engine operating temperature for evidence of overheating. The pressure cap on radiator must make a perfect seal to maintain coolant pressure in the system.



Inspection, Maintenance and Adjustment

PREVENTIVE MAINTENANCE

Routine maintenance and inspections are required to keep your machine in the correct operating condition. The following pages list the inspection intervals, the system or component checks, and location references.

NOTE: *The following pages list the service checks and their required intervals. The service cycles may need to be shortened depending on the working conditions. Extremely hot or dusty conditions will require more frequent service. Operational hours are determined by the amount of time accumulated on the engine hour meter on the control console in the cabin.*

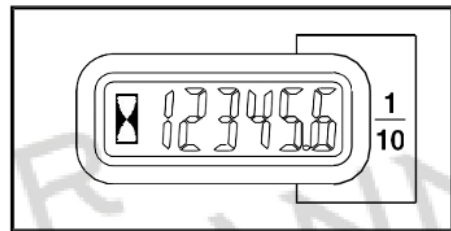

HAOA601L

Figure 1

Product Identification Number (PIN) Location

A PIN number, is stamped on the upper frame, under the boom foot (Figure 2). It is also stamped on the product identification plate (Figure 3) on outside of the cabin on right.

NOTE: *Please make note of these numbers and their locations. These will be required whenever warranty or service work is requested. Keep this number on file, incase the machine is stolen.*

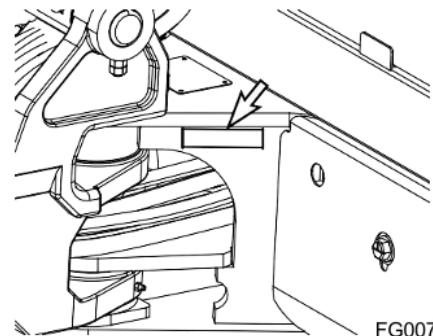

FG007645

Figure 2

Component Serial Numbers

There are many serial numbers on each traceable component of the machine. For example, the engine serial number is stamped on the rear left side of the engine block, above the starter. Additional engine information is described on a label (Figure 4) on the rocker cover.

Please make note of these numbers and their locations. These will be required whenever warranty service work is requested.

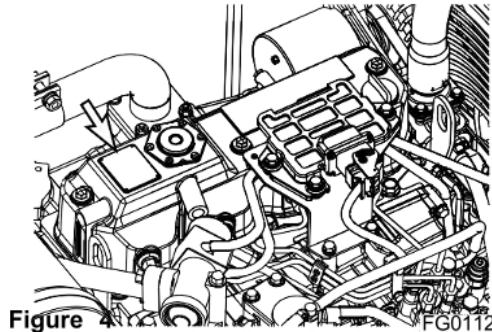

Figure 4
FG011212

Safety Precautions

1. Make sure to lock out the hydraulic controls and post a notice (Warning Tag) that machine is being serviced to prevent any unauthorized operation.
2. Make sure to clean up any fluid spills, especially around the engine.
3. Inspect all fuel lines to make sure that fittings, lines, filters and O-rings, etc., are tight and are not showing signs of wear or damage.
4. If the inspection or test procedure requires that engine be running, make sure to keep all unauthorized personnel away from the machine, and that all industry standard safety precautions are followed.



GÜNTHER
GROSSMANN

PRELIMINARY WORK MACHINE SETUP FOR MAINTENANCE

When performing maintenance specified in this manual, always park the excavator as follows.

NOTE: *Certain types of maintenance may require the machine to be positioned differently. Always return machine to this position.*

1. Park on firm, level ground.
2. Lower bucket to ground.

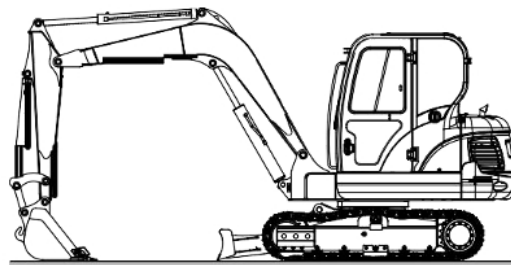

FG010086

Figure 5

3. Set safety lever on "LOCK" position.

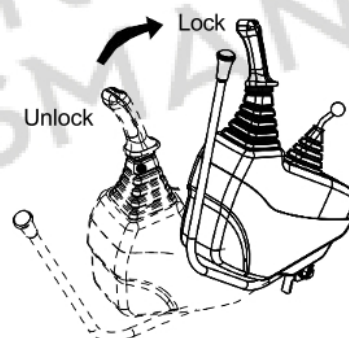

FG010426

Figure 6

4. Allow engine to run at low idle for a minimum of five minutes to allow engine to cool. If this is not done, heat surge may occur.
5. Shut down engine by turning key to "O" (OFF) position. Remove key from starter switch.



WARNING

If engine must be run while performing maintenance, use extreme care. Always have one person in the cabin at all times. Never leave the cabin with the engine running.

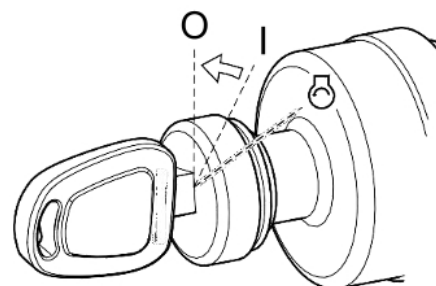

FG008623

Figure 7

6. Before starting maintenance work, hang up a tag, "Do Not Touch When Performing Inspection or Maintenance" on cabin door or work lever.

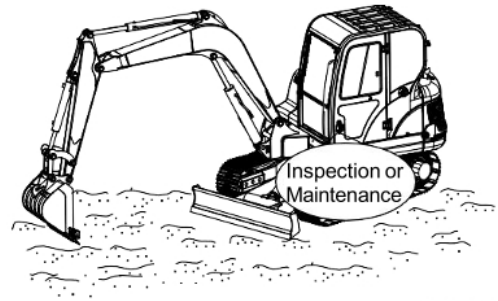

FG010714

Figure 8



It is highly recommend to use the **Günter Grossmann** Genuine Products, or products which meet the specification below. Using other products may damage the equipment.

NOTE: Refer to the Maintenance Intervals Table for application points.

Reservoir	Kind of Fluid	Ambient Temperature								
		-22	-4	14	32	50	68	86	104	122 °F
		-30	-20	-10	0	10	20	30	40	50 °C
Engine Oil Pan	** Engine Oil	SAE 10W-30								
		* SAE 10W-40								
		SAE 15W-40								
		SAE 90 and API GL5								
Swing Drive Case	Gear Oil	* SAE 80W-90 and API GL5								
Final Drive Case		SAE 140 and API GL5								
Hydraulic Oil Tank	*** Hydraulic Oil	ISO VG 32								
		* ISO VG 46								
		ISO VG 68								
		* ASTM D975 No. 2								
Fuel Tank	Diesel Fuel	ASTM D975 No. 1								
		* Multipurpose Lithium Grease NLGI No. 2								
Cooling System	Coolant	Add Antifreeze * (50% antifreeze - 50% distilled water)								
* Installed at factory.										
** Engine oil must meet ACEA-E5 or API-CI-4.										

*** Hydraulic oil change interval is 2,000 hours, only when *RIPAA* Genuine Oil is used. If other brands of oil is used, guaranteed change interval is 1,000 hours. Note that the mixing ratio is for reference purpose only, and is not an absolute standard.

API: American Petroleum Institute.

ACEA: Association des Constructeurs Europens d'Automobiles.

ASTM: American Society of Testing and Material.

ISO: International Standardization Organization.

NLGI: National Lubricating Grease Institute.

SAE: Society of Automotive Engineers.



CAUTION

Do not mix oils from different manufacturers. *Günter Grossmann* does not endorse specific brands but does suggest that owners select quality oils whose suppliers provide assurance that required standards will always be met or exceeded.

IMPORTANT







Fluctuating daily or weekly extremes of temperature, or operation in subzero freezing weather may make it impractical to use straight weight lubricants. Use good judgement in selecting lubricant types that are appropriate for climate conditions.







FLUID CAPACITIES

Component		Capacity
Engine	Oil Pan with Filter	11.6 ℓ (3.06 U.S. gal.)
	Cooling System	10 ℓ (2.5 U.S. gal.)
Fuel Tank		115 ℓ (30.4 U.S. gal.)
Hydraulic Oil	Tank Level	72 ℓ (19.1 U.S. gal.)
	System	108 ℓ (28.6 U.S. gal.)
Travel Reduction Device (Each)		1.4 ℓ (5.0 U.S. gal.)

LUBRICATION AND SERVICE CHART

Lubrication and service chart is on the inside of battery box cover. The symbols shown here are used in the lubrication and service chart on the next page.

Symbol	Description
	Lubrication
	Gear Oil (Swing Device, Travel Device)
	Engine Oil
	Engine Oil Filter
	Hydraulic Oil
	Hydraulic Oil Return Filter
	Hydraulic Oil Tank Breather

Symbol	Description
	Coolant
	Air Cleaner Filter
	Fuel Filter
	Air Conditioner Filter
	Drain Water
	Fuel Water Separator
	Fuel Cap Filter

Description of Lubrication and Service Chart

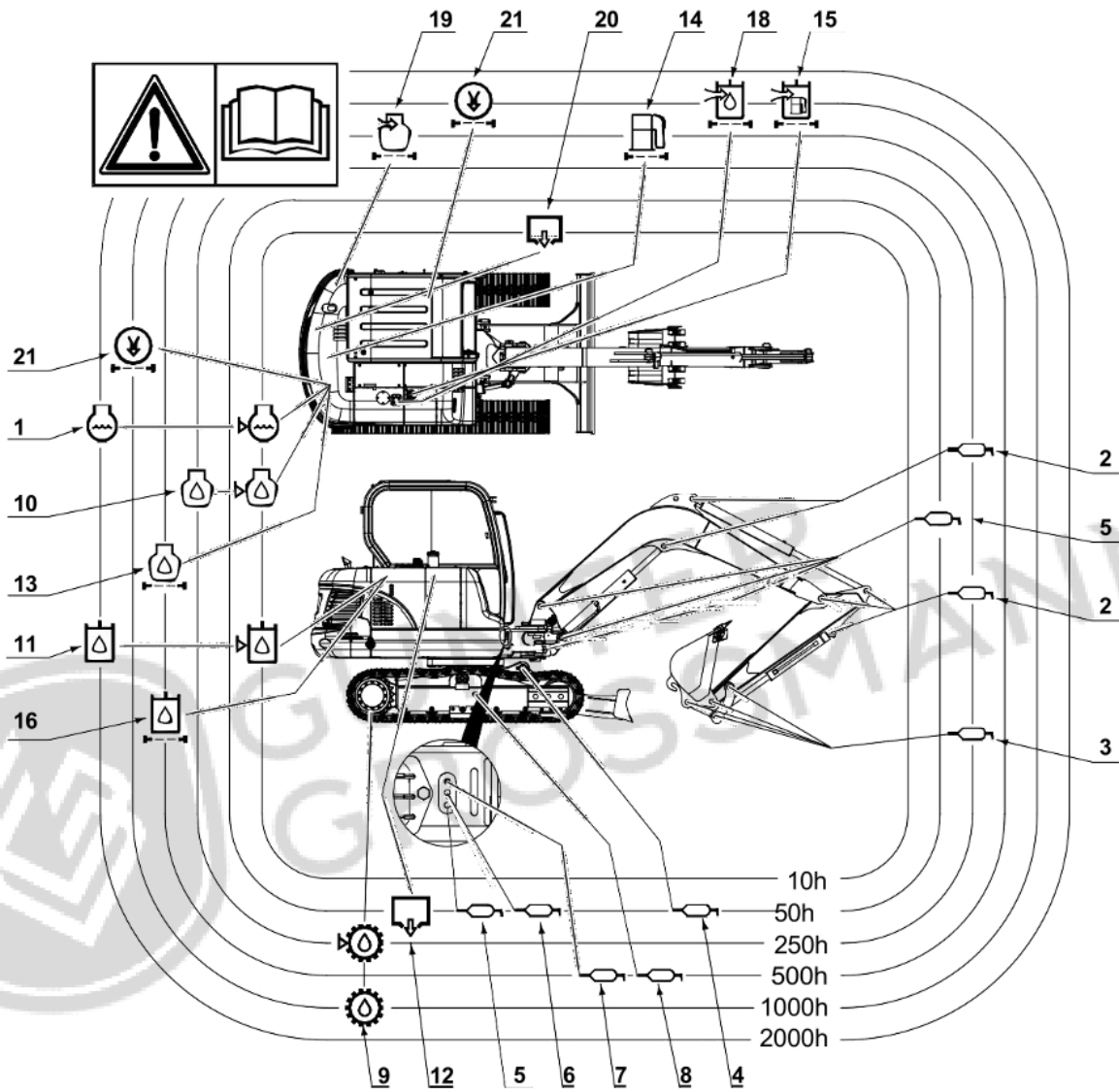

Figure 9

FG016332

SERVICE DATA									
No.	Items to Check	Service	Qty.	DX55					
				Service Interval					
				10	50	250	500	1000	2000
1	Radiator	Coolant (Antifreeze)	10ℓ	V					
2	Boom, Arm Joint Pin	Grease	10	F100		W10			
3	Bucket Joint Pin	Grease	2	F100		W10			
4	Dozer Blade Cylinder Pin	Grease	4	F100	W10				
5	Boom Swing Cylinder Pin	Grease	4	F100					
6	Swing Bearing	Grease	1		W10				
7	Swing Gear	Grease	1						
8	Track Spring	Grease	2				W10		
9	Travel Reduction Device	Gear Oil (80W90)	2X1.4ℓ			F, V			
10	Engine Oil	Engine Oil (10W40)	11.6 ℓ	V	F				
11	Hydraulic Oil Tank	Hydraulic Oil	73ℓ	V					
12	Fuel Tank	Diesel	115ℓ	V					
13	Engine Oil Filter	Cartridge	1		F				
14	Fuel Filter	Cartridge	1						
15	Fuel Cap Filter	Element	1						
16	Hydraulic Oil Return Filter	Element	1			F			
17	Hydraulic Oil Suction Strainer	Strainer	1					C	
18	Air Breather Filter	Element	1						
19	Air Cleaner (Outer)	Element	1		C				
	Air Cleaner (Inner)	Element	1						
20	Fuel Water Separator	Drain Water	1	V					
21	Air Conditioner Filter (Inner)	Cartridge	1				C		
V: Maintenance and Refill.									
C: Cleaning.									
F: Change First Time Only.									
F100: Every 10 Hours For First 100 Hours.									
W10: Every 10 Hours If Operating In Water.									
EG: Ethylene Glycol - Günter Grossmann Genuine Antifreeze Solution (Drain and replace using this interval.) See "Engine Cooling System" on page 4-60, for further explanation.									
PG: Propylene Glycol - Günter Grossmann Genuine Antifreeze Solution (Drain and replace using this interval.) See "Engine Cooling System" on page 4-60, for further explanation.									
■: Replacement On Every Interval.									
NOTE: For additional service items see list of "Maintenance Intervals" on page 4-10.									

MAINTENANCE INTERVALS

SERVICE ITEM	PAGE
10 Hour / Daily Service	
Grease Boom, Arm and Front Attachment Pins (for first 100 hours)	4-12
Check Engine Oil Level	4-12
Check Level of Hydraulic Oil Tank	4-13
Check for Leaks in Hydraulic System	4-14
Check Fuel Level	4-14
Check for Leaks in Fuel System	4-15
Check Fuel Water Separator and Drain Water as Required	4-15
Check Cooling System and Refill as Required	4-16
Check Level of Window Washer Liquid	4-16
Inspect Cooling Fan Blade	4-17
Check Air Intake System	4-17
Inspect Seat Belt for Proper Operation	4-17
Inspect the Structure for Cracks and Faulty Welds	4-17
Check the Operation of All Switches	4-18
Check the Operation of All Exterior Lights, Horn and Control Console Indicator and Monitor Lights	4-18
Start Engine, Check Starting Ability, and Observe Exhaust Color at Start-up and at Normal Operating Temperature. Listen for Any Abnormal Sounds	4-18
Check Operation of All Controls	4-18
50 Hour / Weekly Service	
Perform All Daily Service Checks	4-19
Grease Dozer Pins	4-19
Grease Boom Swing Cylinder and Bracket	4-19
Grease Swing Gear Pinion Teeth	4-19
Grease Swing Bearing	4-19
Drain Water and Sediment from Fuel Tank	4-20
Clean Outer Filter of Air Cleaner	4-20
Check Engine Fan Belt for Cracks, Wear and Correct Tension (After First 50 Hours)	4-21
Change Engine Oil and Filter (After First 50 Hours)	4-21
Inspect the Track Assemblies for Proper Tension and Loose, Worn or Damaged Parts (Links, Shoes, Rollers, Idlers)	4-21
250 Hour / Monthly Service	
Perform All Daily and 50 Hour Service Checks	4-22
Grease Arm and Front Attachment Pins	4-22
Change Engine Oil	4-26
Check Engine Fan Belt Tension	4-27
Check Engine Fan Belt Wear	4-27
Check Oil Level in Travel Reduction Device (One on Each Side of Unit)	4-28
Change Oil in Travel Reduction Device (One on Each Side of Unit) (After First 250 Hours)	4-29
Replace Hydraulic Oil Return Filter (After First 250 Hours)	4-29
Clean Hydraulic Oil Suction Strainer (After First 250 Hours)	4-29

SERVICE ITEM	PAGE
Inspect Pins and Bushings of the Front End Attachments for Signs of Wear	4-29
Check Fluid Levels in Batteries and Battery Charge Levels	4-29
Inspect for Any Loose or Missing Nuts and Bolts	4-29
Inspect Fuel System Hose Clamps	4-29
500 Hour / 3 Month Service	
Perform All Daily, 50 and 250 Hour Service Checks	4-30
Grease Swing Gear and Pinion	4-30
Grease Track Spring	4-31
Change Engine Oil Filter	4-34
Replace Outer and Inner Air Cleaner Filters	4-35
Change Fuel Filter	4-36
Replace Hydraulic Oil Return Filter	4-37
Clean Air-conditioning Inner Filter	4-38
1,000 Hour / 6 Month service	
Perform All Daily, 50, 250 and 500 Hour Service Checks	4-39
Change Oil in Travel Reduction Device (One on Each Side of Unit)	4-39
Change Air-conditioning Inner Filter	4-40
Clean Hydraulic Oil Suction Strainer	4-40
Change Air Breather Filter	4-42
Change Fuel Cap Filter	4-42
Check Air Conditioner Refrigerant	4-44
Check and Adjust Engine **	4-44
2,000 Hour / Yearly Service	
Perform All Daily, 50, 250, 500 and 1,000 Hour Service Checks	4-45
Change Radiator Coolant	4-45
Hydraulic Oil Exchange and Suction Strainer Cleaning	4-46
Check Alternator and Starter**	4-47
Check All Rubber Antivibration Shock Mounts	4-47
Perform and Record the Results of the Cycle Time Tests	4-48
Inspect Machine to Check for Cracked or Broken Welds or other Structural Damage	4-48
Check, Adjust Valve Clearance **	4-48
Check Head Bolt Torques	4-48

** These checks need to be completed by an authorized
Günter Grossmann dealer.

10 HOUR / DAILY SERVICE

Grease Boom, Arm and Front Attachment Pins (for first 100 hours)

WARNING

Do not remove grease fitting until the pressure is entirely bled off by loosening grease fitting slowly to avoid fatal wound.

Let anybody never be in the blowing direction.

Be careful to any kinds of works for nipples and hydraulic line plugs.

Grease every 10 hours for first 100 hours and every 50 or 250 hours thereafter (See page 4-22).

NOTE: *If the unit has been running or working in water the front attachment should be greased on a 10 hour / daily basis.*

Check Engine Oil Level

WARNING

Allow the engine to cool before checking the oil level to avoid burns by touching hot engine parts.

NOTE: *When checking level using a dipstick always remove and wipe it clean before making final level check.*

1. Shut down engine and wait for fifteen minutes. This will allow all oil to drain back to oil pan.
2. Remove dipstick (1, Figure 11) and wipe the oil off with a clean cloth.
3. Insert dipstick fully in the oil gauge tube, then take it out again.
4. Engine oil level must be between "HIGH" and "LOW" marks on dipstick.

NOTE: *If oil is above "HIGH" mark on dipstick, some must be drained to return oil to proper level.*

5. Add oil through engine oil fill cap (2, Figure 11), if the oil level is below the "LOW" mark.

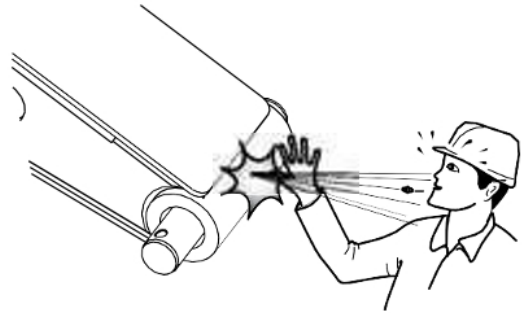

FG010121

Figure 10

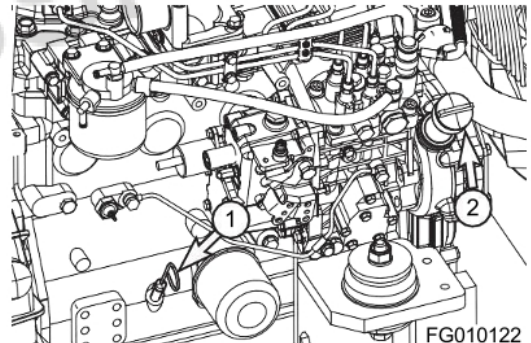
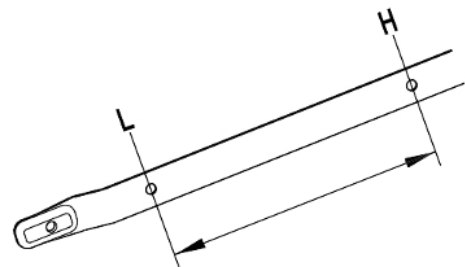

Figure 11



FG000616

Figure 12

Check Level of Hydraulic Oil Tank

WARNING

The hydraulic oil will be hot after normal machine operation. Allow the system to cool before attempting to service any of the hydraulic components.

1. Park machine on firm, level ground. Lower boom and position bucket on ground as shown in Figure 13.
2. Set engine speed to "LOW IDLE."

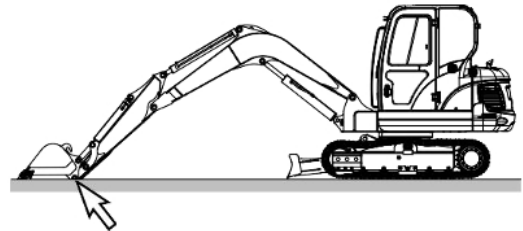

FG010123

Figure 13

3. Set safety lever to "LOCK" position.
4. Check level gauge by opening right access door. Oil level must be between marks on sight gauge.

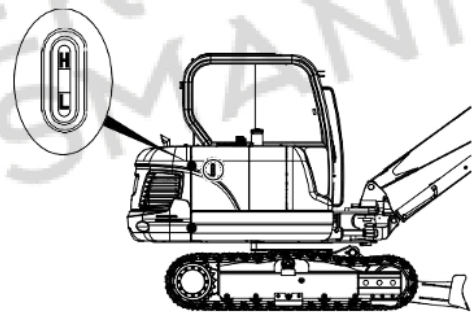

FG011293

Figure 14

5. If the level is below "L" mark add oil.
 - A. Shut down engine.
 - B. The hydraulic tank is pressurized. Turn the breather cap slowly to allow the pressurized air to vent.
 - C. Remove upper cover of the hydraulic tank and add oil.

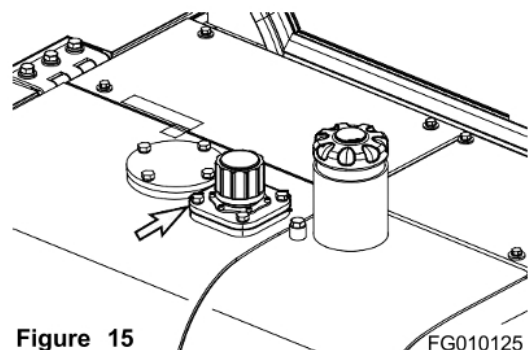

Figure 15

FG010125

IMPORTANT

Do not fill above "H" mark on sight gauge. Overfilling can result in damage to equipment and oil leaking from hydraulic tank because of expansion.

6. If oil level is above the "H" mark drain oil.
 - A. Shut down engine and wait for the hydraulic oil to cool down.
 - B. Drain the excess oil from drain valve (Figure 16) at the bottom of the tank into a suitable container, using a hose connected to the valve.

NOTE: *Dispose of drained fluids according to local regulations.*

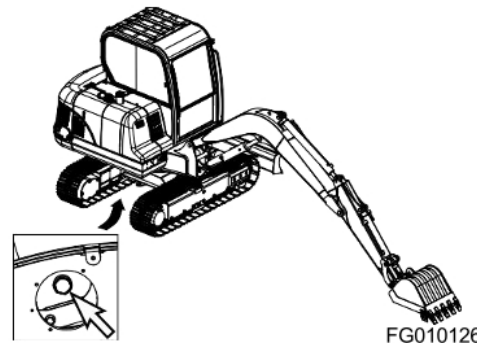

Figure 16

Check for Leaks in Hydraulic System

1. Perform a daily walk-around inspection to make sure that hoses, piping, fittings, cylinders and hydraulic motors are not showing any signs of leakage. If any is noted, determine the source of the leak and repair.

Check Fuel Level



WARNING

Use extreme safety precautions while refueling to prevent explosions or fire.

Immediately clean up any split fuel.

1. At end of each workday, fill fuel tank. Add fuel through fuel fill tube (2, Figure 17). When working at a temperature of 0°C (32°F) or higher, use ASTM No. 2- D or its equivalent. At temperatures below 0°C (32°F) use ASTM No. 1-D or its equivalent.
2. Make sure that fuel fill hose is grounded to the excavator before fueling begins.
3. Check the amount of fuel in the tank by observing the fuel tank sight gauge (1, Figure 17).

NOTE: *See "Fluid Capacities" on page 4-7. for capacity.*

4. The excavator may be equipped with the optional battery operated fuel fill pump. The pump assembly is in the hydraulic pump compartment. Put the suction hose of the pump into the fuel resupply tank. Turn the switch in the pump compartment "ON," and the fuel will be pumped into the excavator fuel tank.

NOTE: *See "Fuel Transfer Pump (Optional)" on page 4-63, for further information.*

5. Do not overfill the tank.

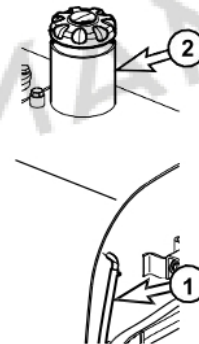
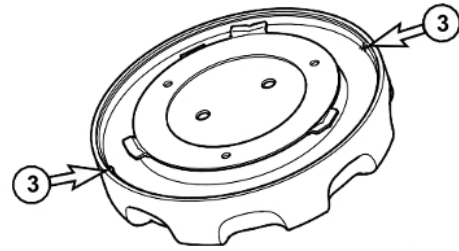

Figure 17

- Securely tighten cap after fueling.

NOTE: If breather holes (3, Figure 18) in cap are clogged, a vacuum may form in the tank preventing proper fuel flow to engine. Keep holes in fuel cap clean.



FG000317

Figure 18

Check for Leaks in Fuel System

- Perform an inspection of the engine compartment to verify that fuel system is not leaking. If any is noted, determine the source of the leak and repair.

Check Fuel Water Separator and Drain Water as Required

The cup of the separator is made from semi-transparent material. In the cup is a red colored float ring. The float ring will rise to the surface of the water to show how much needs to be drained. Also, some optional fuel filter / water separators are equipped with a sensor to detect the amount of contaminants. This sensor sends a signal to an indicator to alert the operator.

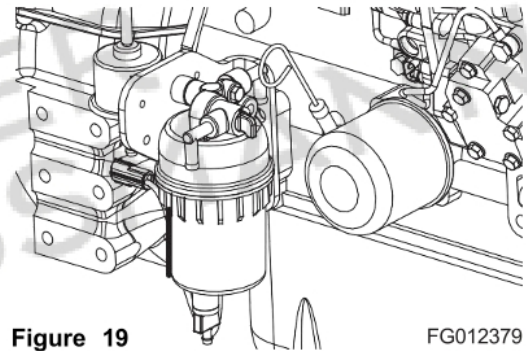

FG012379

Figure 19

Drain the fuel filter / water separator as follows:

- Position an approved container under the fuel filter / water separator (1, Figure 20) to collect the contaminants.
- Close (2, Figure 20) the fuel cock (3, Figure 20).
- Loosen the drain cock (4, Figure 20) at the bottom of the fuel filter / water separator. Drain any water collected inside.
- Hand-tighten the drain cock.

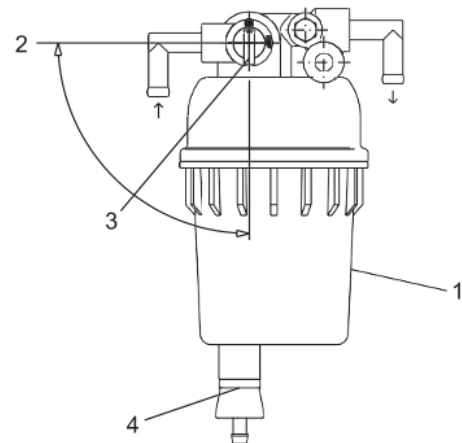

FG012380

Figure 20



CAUTION

If the fuel filter / water separator is positioned higher than the fuel level in the fuel tank, water may not drip out when the fuel filter / water separator drain cock is opened. If this happens, turn the air vent screw on the top of the fuel filter / water separator 2-3 turns counterclockwise. Be sure to tighten the air vent screw after the water has drained out.

5. Open the fuel cock (3, Figure 20).
6. Be sure to prime the diesel fuel system when you are finished.
7. Check for leaks.

Check Cooling System and Refill as Required

WARNING

Allow the engine to cool before releasing the radiator cap. Make sure to loosen the cap slowly to release any remaining pressure.

Radiator cleaning is performed while the engine is running. Take extreme caution when working on or near a running engine. Make sure to lock out and tag the controls notifying personnel that service work is being performed.

Do not remove radiator cap unless it is required. Observe the coolant level in the coolant recovery tank.

NOTE: Do not mix ethylene glycol and propylene glycol antifreeze together. If the two are mixed, the protection level will be reduced to the level of the ethylene glycol.

1. When the engine is cold, remove radiator cap and check the coolant level inside the radiator. Do not rely on the level of coolant in the coolant recovery tank. Refill radiator as required. Refer to coolant concentration table.
2. Check to make sure that coolant transfer line from the coolant recovery tank to the radiator is free and clear of obstructions, or not pinched.
3. Observe the level of coolant in the coolant recovery tank. The normal cold engine fluid level should be between "FULL" and "LOW" marks on tank.
4. If the coolant is below the "LOW" mark, add coolant to this tank.

Check Level of Window Washer Liquid

1. Open left front access door and check fluid level in windshield washer tank.
2. Open fill cap and add fluid.

NOTE: Use a washer liquid that is rated for all seasons. This will prevent freezing during cold weather operation.

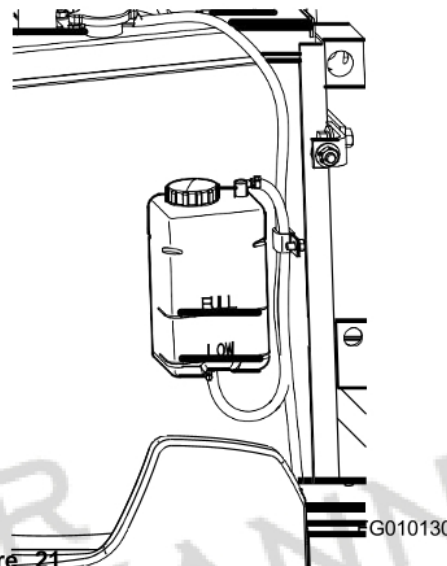

Figure 21

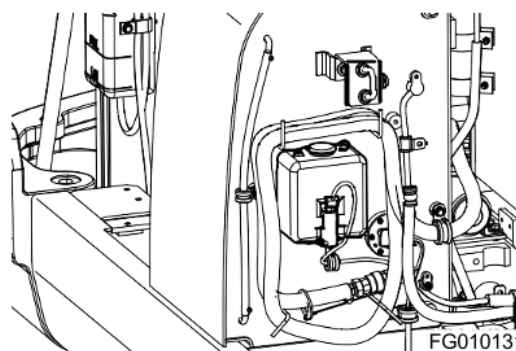

Figure 22

Inspect Cooling Fan Blade

WARNING

Personal injury can result from a fan blade failure. Never pull or pry on the fan. This can damage the fan blade (s) and cause fan failure.

1. An inspection of the cooling fan is required daily. Check for cracks, loose bolts, bent or loose blades, and for contact between the blade tips and the fan shroud. Check the fan to make sure it is securely mounted. Tighten the bolts if necessary. Replace any fan that is damaged.

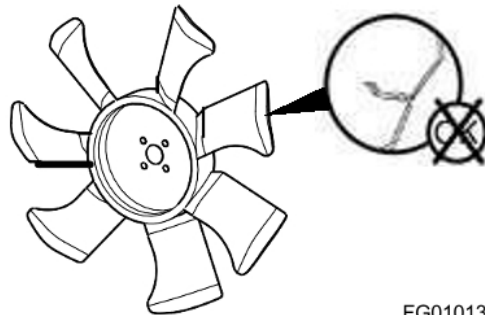

Figure 23

FG010132

Check Air Intake System

CAUTION

Hot engine components can cause burns.

Avoid contact with hot engine components

1. Park the machine on a level surface, lower the attachment to the ground, set safety lever to "LOCK" position, and shut down engine.
2. Check the engine intake hose, and hose bands for damage and tightness.
3. If damaged, wrinkled, or loose, replace or retighten or contact your nearest *Günter Grossmann* dealer.

IMPORTANT

Severe engine damage will result from running with unfiltered air.

Do not operate engine if any leaks or defects are found on air intake system.



Figure 24

HAOA050L

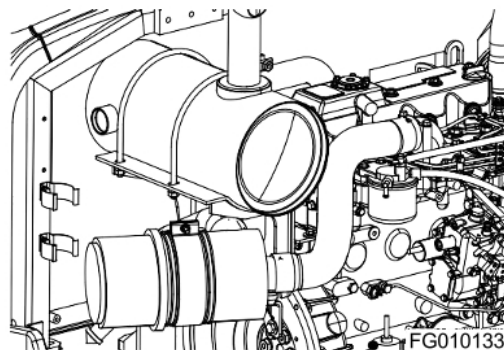

Figure 25

FG010133

Inspect Seat Belt for Proper Operation

Inspect the Structure for Cracks and Faulty Welds

1. During the daily walk-around inspection and when greasing the machine, look for any visible damage to the machine. Repair or replace any damaged parts before operating the machine.

Check the Operation of All Switches

1. Verify the working condition of all switches before starting the engine.

Check the Operation of All Exterior Lights, Horn and Control Console Indicator and Monitor Lights

1. Turn engine starter switch to the "I" (ON) position and observe all the indicator lights.
2. Restore operation of any lightbulbs that do not turn "ON" now.
3. Sound the horn. Repair or replace if required.
4. Turn "ON" and inspect all exterior work lights. Replace any monitors, burned-out bulbs or cracked or broken housings or lenses.

Start Engine, Check Starting Ability, and Observe Exhaust Color at Start-up and at Normal Operating Temperature. Listen for Any Abnormal Sounds

Check Operation of All Controls

IMPORTANT

Cold weather operation requires that operator fully warm up the hydraulic oil before beginning machine operation. Follow all warm up instructions listed in the Operating Instruction section of this manual. Make sure to cycle oil through all the components, including all cylinders, both travel motors and the swing motor. Cold hydraulic oil in the lines and components needs to be warmed before beginning full operation. If this is not done, damage to the cylinders or hydraulic motors can occur.

1. With the engine at rated speed, operate all the controls.
2. Follow cold weather hydraulic system warm-up procedures.
3. Note any slow operations or unusual movements. Determine the cause and repair the fault before operating.

50 HOUR / WEEKLY SERVICE

Perform All Daily Service Checks

Grease Dozer Pins

- A. Dozer pins (2 points).
- B. Dozer cylinder (2 points).

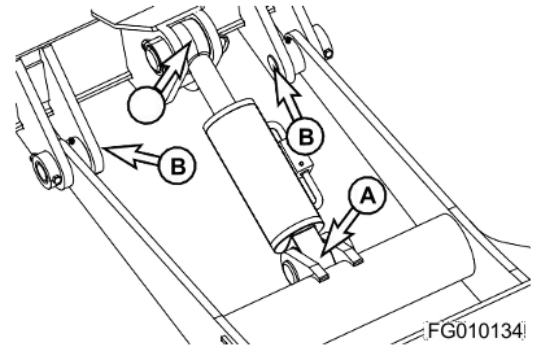

Figure 26

Grease Boom Swing Cylinder and Bracket

There are four grease fittings for the boom swing cylinder and bracket.

Do not over lubricate. When replacing oil grease with new purge the used off.

- 1. Boom swing cylinder head (C, Figure 27 - 1 point).
- 2. Boom swing cylinder rod (D, Figure 28 - 1 point).
- 3. Boom swing bracket (E, Figure 28 - 2 points).

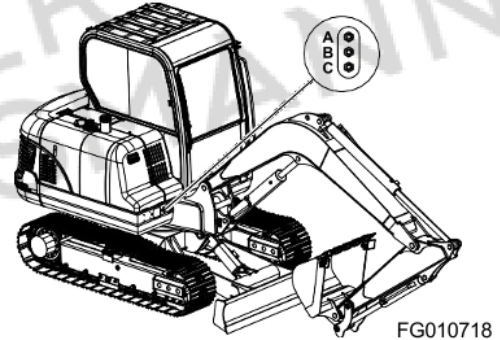
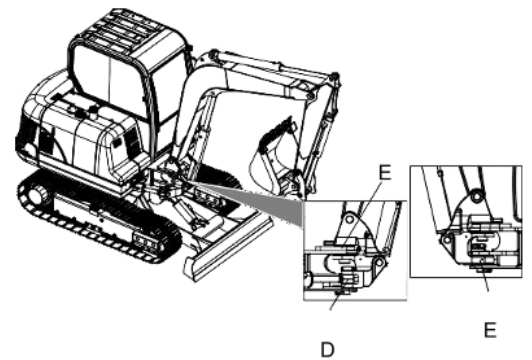

Figure 27

Grease Swing Gear Pinion Teeth

- 1. Inject two or three strokes of grease through the grease fitting (A, Figure 27).
- 2. Lift bucket about 20 cm (8 in) from ground. Turn upper body 90° at a time for two full turns, greasing the swing gear pinion teeth at each stop.



Grease Swing Bearing

- 1. Inject grease through the grease fittings (B, Figure 27) using a grease gun.
- 2. Lift bucket about 20 cm (8 in) from ground. Turn upper body 90° at a time for two full turns, greasing the swing gear pinion teeth at each stop.

Figure 28

Drain Water and Sediment from Fuel Tank

1. Perform this procedure before operating the machine.
2. Drain water and sediment from bottom of fuel tank into a suitable container.

NOTE: *Dispose of drained fluid according to local regulations.*

NOTE: *Always completely fill fuel tank at end of each workday to prevent condensation from forming on the inside walls of the tank.*

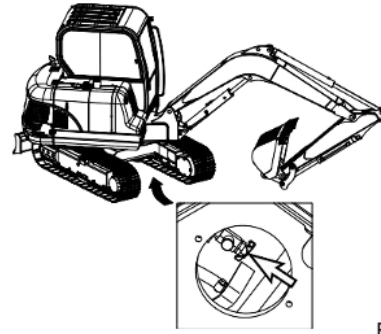

FG010135

Figure 29

Clean Outer Filter of Air Cleaner

NOTE: *When working in severely dusty conditions, the service interval should be shortened.*

WARNING

Never clean or attempt to remove air cleaner filter if the engine is running.

If using compressed air to clean the filter, make sure that proper eye protection is worn.

1. Locate the air cleaner assembly.
2. Remove and clean rubber evacuator valve (1, Figure 30) from bottom of air cleaner housing cover (2, Figure 30). Inspect seal lips for wear or damage. Replace valve if necessary.

NOTE: *Install evacuator valve with lips parallel to the cover.*

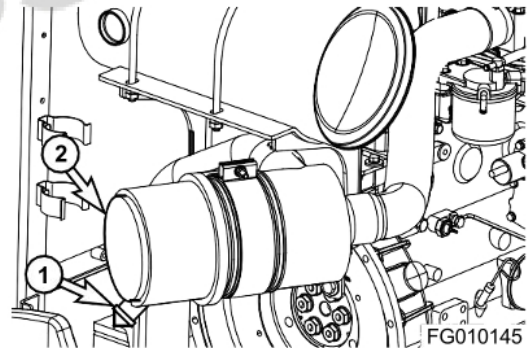

FG010145

Figure 30

3. Remove access cover (2, Figure 31) by loosening the latches (3, Figure 31).
4. Remove outer filter (4, Figure 31) from the housing. Do not remove inner filter (5, Figure 31).

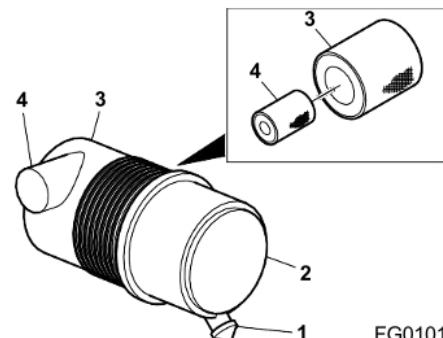

FG010146

Figure 31

- Clean the outer filter (4, Figure 32) by blowing compressed air from the inside of the filter towards the outside. Do not use more than 205 kPa (30 psi) air pressure.



HAOC570L

Figure 32

- Check outer filter by shining light through it. If small holes or thinner parts are found on the element after cleaning, replace the filter.
- Clean the inside of the air cleaner body and the inside of the air cleaner cover. Do not use compressed air.
- Properly install the air filter and cover.
- After filter service be sure to install cover with arrows pointing "UP."

If after cleaning the outer filter, the air cleaner clogged indicator remains "ON," replace the outer and inner filters. Do not clean inner filter.

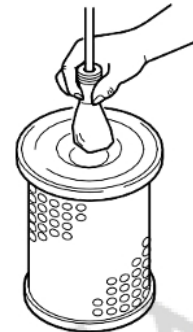

FG000412

Figure 33

Check Engine Fan Belt for Cracks, Wear and Correct Tension (After First 50 Hours)

- Inspect after first 50 hours of operation and every 250 hours thereafter. For details, See "Check Engine Fan Belt Tension" on page 4-27.

Change Engine Oil and Filter (After First 50 Hours)

- Change engine oil and filter after first 50 hours of operation or rebuild, then engine oil every 250 and engine oil filter every 500 thereafter. For details, See "Change Engine Oil" on page 4-26 and See "Change Engine Oil Filter" on page 4-34.

Inspect the Track Assemblies for Proper Tension and Loose, Worn or Damaged Parts (Links, Shoes, Rollers, Idlers)

- Do a daily walk-around inspection of all components including the track assemblies. Look for missing, damaged or excessively worn parts. See "Grease Track Spring" on page 4-31.
- Jack up each track and perform the two speed travel motor test.

250 HOUR / MONTHLY SERVICE

Perform All Daily and 50 Hour Service Checks

Grease Arm and Front Attachment Pins

Grease every 10 hours for first 100 hours and every 250 hours thereafter.

NOTE: *If the unit has been running or working in water the front attachment should be greased on a 10 hour / daily basis.*

- Position machine as shown below and lower the front attachment to the ground and shut down engine
- Press the grease fitting and inject grease with the grease gun on the marked point
- After injection, clean off the old grease that has been purged.



GÜNTER
GROSSMANN

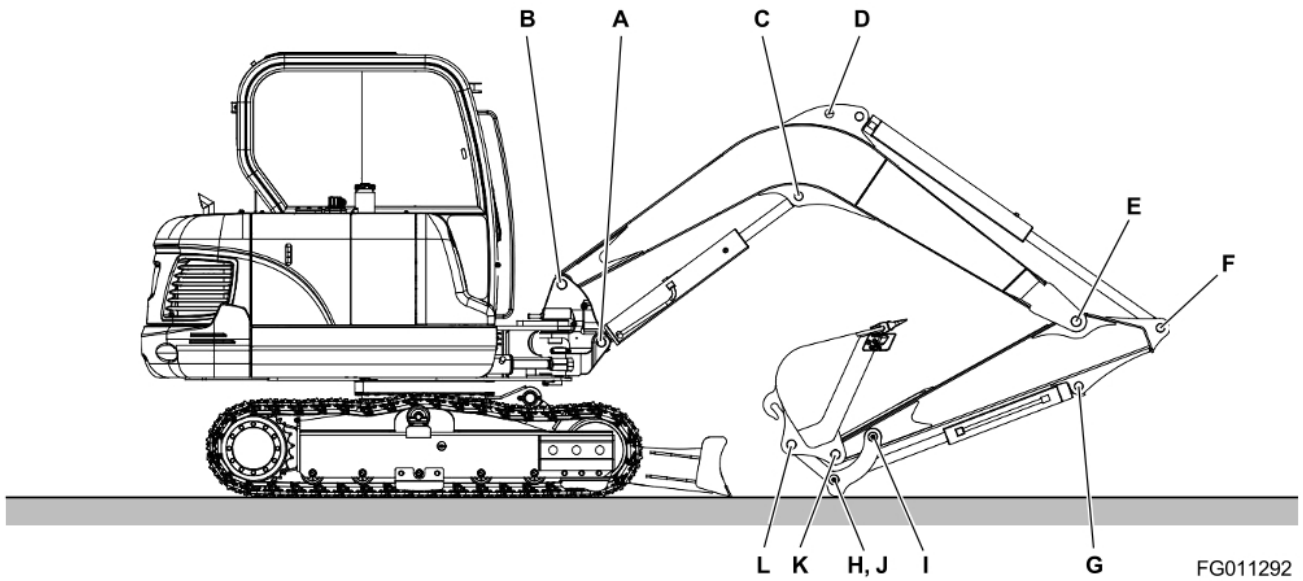

FG011292

Figure 34

Reference Number	Description
A	Boom Cylinder Head Pin (1 Point)
B	Boom Foot Pin (1 Point)
C	Boom Cylinder Rod Pin (1 Point)
D	Arm Cylinder Head Pin (1 Point)
E	Boom Arm Joint Pin (1 Point)
F	Arm Cylinder Rod Pin (1 Point)

Reference Number	Description
G	Bucket Cylinder Head Pin (1 Point)
H, I	Link Joint Pin (2 Points)
J	Bucket Cylinder Rod Pin (1 Point)
K	Arm Bucket Joint Pin (1 Point)
L	Bucket Link Joint Pin (1 Point)

A. Boom Cylinder Head Pin (1 Point)

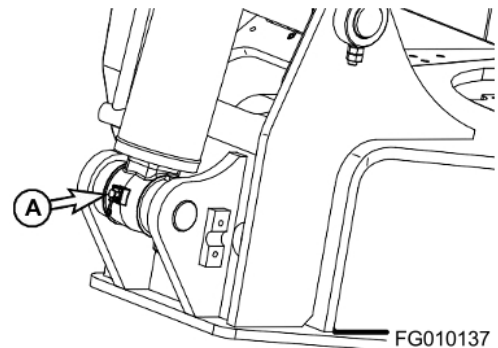

FG010137

Figure 35

B. Boom Foot Pin (1 Points)

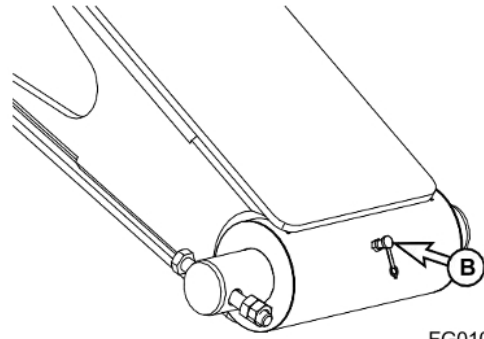

FG010138

Figure 36

C. Boom Cylinder Rod Pin (1 Point)

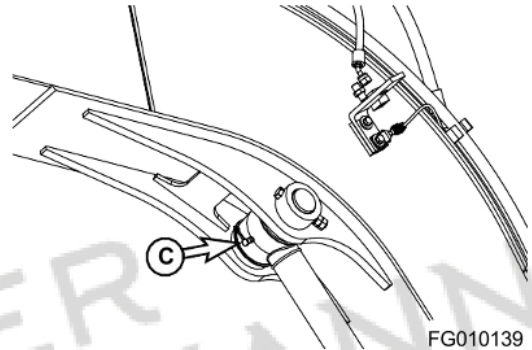

FG010139

Figure 37

D. Arm Cylinder Head Pin (1 Point)

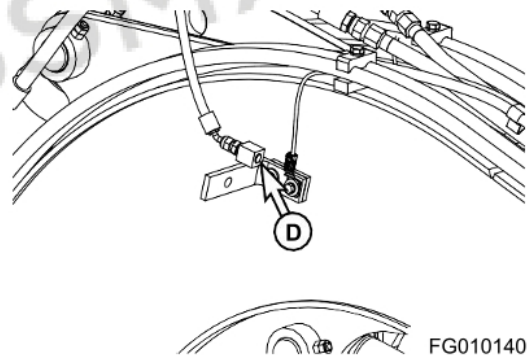

FG010140

Figure 38

E. Boom Arm Joint Pin (1 Point)

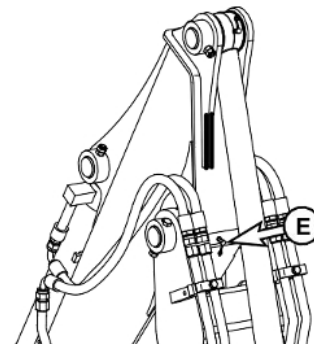

FG010141

Figure 39

F. Arm Cylinder Rod Pin (1 point)

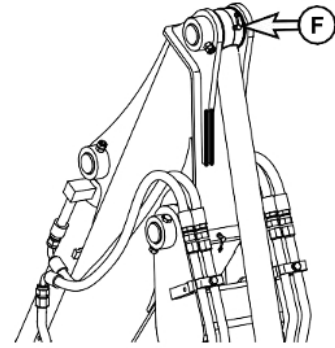

FG010525

Figure 40

G. Bucket Cylinder Head Pin (1 Point)

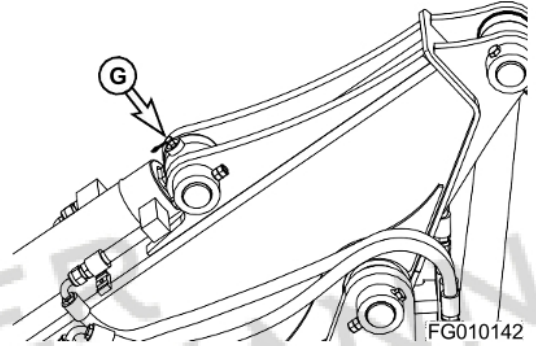

FG010142

Figure 41

H, I. Link Joint Pin (2 Points)

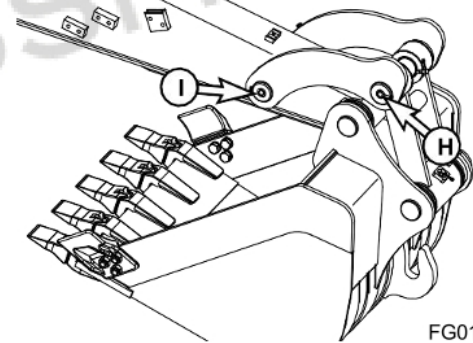

FG010143

Figure 42

J. Bucket Cylinder Rod Pin (1 Point)

K. Arm Bucket Joint Pin (1 Point)

L. Bucket Link Joint Pin (1 Point)

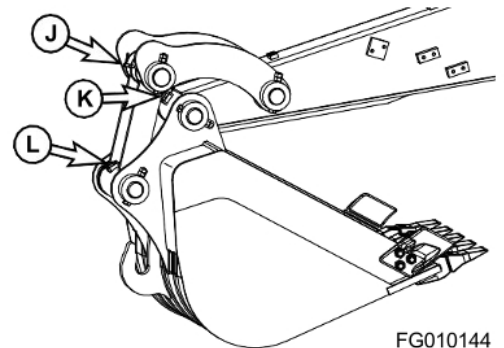

FG010144

Figure 43

Change Engine Oil

NOTE: Change engine oil and filter after first 50 hours of operation or rebuild, then every 250 thereafter.

WARNING

DO NOT change oil on a hot engine. Allow the engine to cool down before attempting to change the engine oil to avoid burns by touching hot engine parts.

1. Position a larger container under the engine. Remove cap (1, Figure 44) and install hose (2) to drain the engine oil. Remove hose (2) and install cap (1).

NOTE: Dispose of drained fluids according to local regulations.

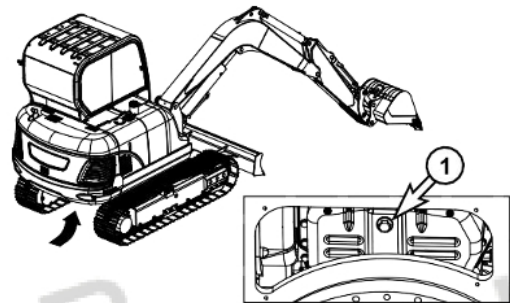

FG010147

Figure 44

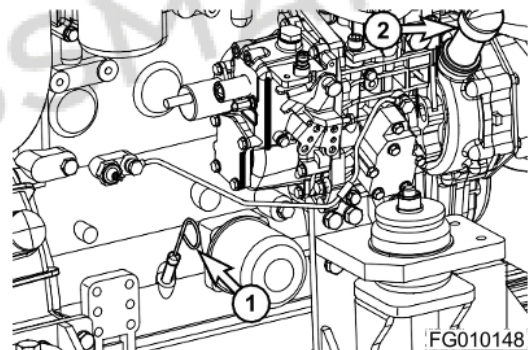

FG010148

Figure 45

Check Engine Fan Belt Tension

IMPORTANT

A loose fan belt can cause engine overheating, poor charging, and/or premature belt wear. A belt that is too tight can cause damage to the water pump, alternator bearing or belt.

1. Inspect every 250 hours. (Inspect after first 50 hours of operation.)
2. With the engine shut off, check the tension of the fan belt by pressing downwards on the belt, midway between the fan pulley and alternator pulley. The belt should flex approximately 10 mm (0.4 in). See Figure 46. To adjust the belt, loosen the alternator adjustment plate bolts, adjust the belt tension and retighten the bolts.

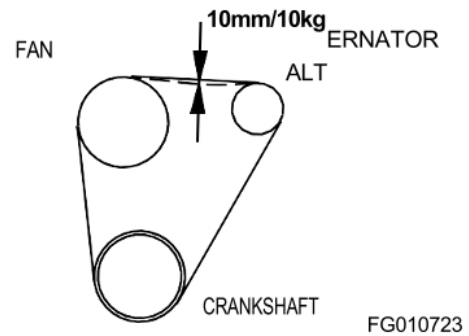

Figure 46

FG010723

Check Engine Fan Belt Wear



WARNING

Keep clear of engine fan and fan drive belts when the engine is running. Rotating fan and belt contact can cause injury.



WARNING

When checking, adjusting or replacing drive belts, care must be taken to prevent accidental cranking of the engine. Be sure the starter switch is in the "OFF" position and the controls are tagged.

1. Replace badly worn, greasy or severely cracked belts immediately. These conditions prevent proper belt function. Visually inspect the belt. Check the belt for intersecting cracks. Transverse (across the belt width) cracks are acceptable. Longitudinal (direction of belt length) cracks that intersect with transverse cracks are not acceptable. Replace the belt if it is frayed or has pieces of material missing.
2. Before installing new belts, make sure all pulley grooves are clean and not worn. Replace pulley, if damaged, or if the grooves are worn.
3. All pulley support bearings, shafts, and brackets must be in working order.

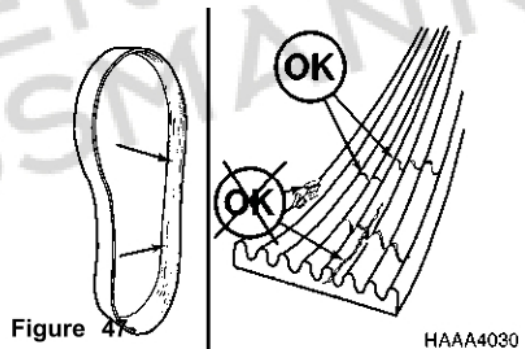

Figure 47

HAAA4030

4. When replacing belts and pulleys, pulley alignment must be checked with belts tensioned and brackets securely clamped. A misalignment that can be detected by the eye is detrimental to belt performance.
5. Do not force the belts into the pulley grooves by prying with a screwdriver or pry bar. This will damage the belt side cords, which will cause the belts to turn and result in complete destruction of the belts in operation.
6. Belts on new machines and replacement belts lose their tension as they seat into the pulley grooves. Check the tension of new belts at 50 hour intervals until tension is stabilized and thereafter, every 250 hours. If the tension falls below the required minimum, the belt slips damaging the belts and pulley grooves.

NOTE: *When operating in abrasive conditions, check tension every 100 hours.*

Check Oil Level in Travel Reduction Device (One on Each Side of Unit)



WARNING

The gear oil is very hot after the machine has been operating. Shut all systems down and allow them to cool. Before fully removing any motor case inspection port plug, etc., loosen the plug slightly to allow pressurized air to escape.

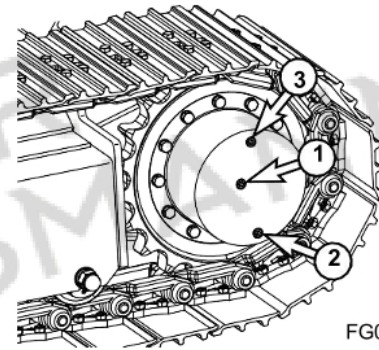

Figure 48

FG010149

1. Make sure that machine is on firm, level ground.
2. Rotate the track until ports (1 thru 3, Figure 48) are in their proper positions as shown.
3. Loosen fill plug (3, Figure 48) slightly to allow pressurized air to escape.
4. Remove oil level plug (1, Figure 48).
5. Check oil level. The oil should be near the bottom of the level plug opening.
6. Add oil through the fill plug (3, Figure 48) opening, if necessary.
7. Clean and install oil level and fill plugs (1 and 3, Figure 48).
8. Repeat this procedure on the other travel reduction device.

Change Oil in Travel Reduction Device (One on Each Side of Unit) (After First 250 Hours)

NOTE: *Drain and refill oil after first 250 hours of operation or rebuild,
and every 1,000 hours thereafter (See page 4-39).*

Replace Hydraulic Oil Return Filter (After First 250 Hours)

NOTE: *Replace hydraulic oil return filter after first 250 hours
of operation or rebuild, then every 500 hours thereafter
(See page 4-37).*

Clean Hydraulic Oil Suction Strainer (After First 250 Hours)

NOTE: *Clean hydraulic oil suction strainer after first 250 hours
of operation or rebuild, then every 1,000 hours thereafter
(See page 4-40).*

Inspect Pins and Bushings of the Front End Attachments for Signs of Wear

Check Fluid Levels in Batteries and Battery Charge Levels

Inspect for Any Loose or Missing Nuts and Bolts

Inspect Fuel System Hose Clamps

500 HOUR / 3 MONTH SERVICE

Perform All Daily, 50 and 250 Hour Service Checks

Grease Swing Gear and Pinion



WARNING

Greasing swing gear and pinion must be serviced by only one person.

1. Remove inspection cover and inspect the condition of the grease. Make sure that water or other contaminants are not noticeable.

NOTE: *The upper structure must be rotated a little at a time so the entire face of the swing gear can be lubricated. Use extreme caution when performing this operation.*

2. If water or other contaminations are found, remove lower access cover so the gear teeth can be thoroughly cleaned and lubricated.
3. Install access covers after lubricating gear teeth.

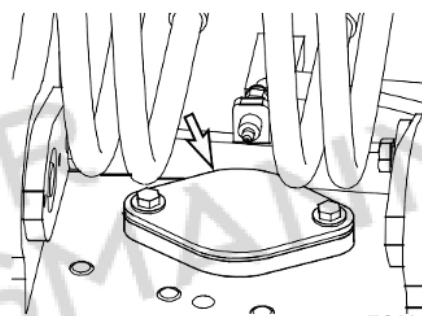

Figure 49

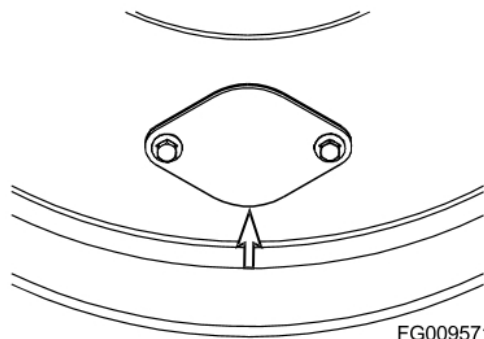

Figure 50

Grease Track Spring

WARNING

Safely measuring track tension requires two people. One person must be in the operator's seat, running the controls to keep one side frame in the air, while the other person makes dimensional checks. Take all necessary precautions to make sure the machine won't move or shift position during service. Warm up the engine to prevent stalls, travel the excavator to an area that provides level, uniform ground support and/or use support blocks when necessary.

The track adjusting mechanism is under very high-pressure. NEVER release pressure suddenly. The track tension grease valve should never be backed off more than one complete turn from the fully tightened down position. Bleed off pressure slowly and keep your body away from the valve at all times.

Track shoe link pins and bushings wear with normal usage, reducing track tension. Periodic adjustment is necessary to compensate for wear and it may also be required by working conditions.

1. Track tension is checked by jacking up one side of the excavator. See Figure 51. Place blocking under frame while taking measurement.

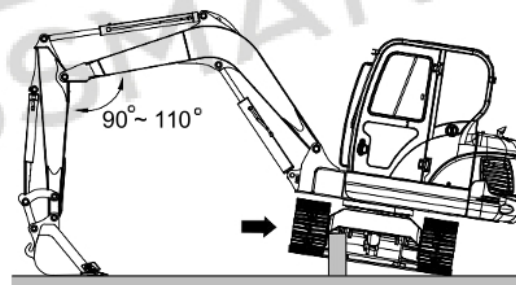

FG011256

Figure 51

- Measuring the distance (A, Figure 52) between the bottom of the side frame and the top of the lowest crawler shoe. Recommended tension for operation conditions are as following.

Terrain Type	Distance "A"
Soil	140 - 150 mm (5.51 - 5.91 in)
Gravel, Sand, Soft Soil	150 - 160 mm (5.91 - 6.30 in)
Rock Bed	120 - 130 mm (4.72 - 5.12 in)

NOTE: *This measurement can be thrown off if there is too much mud or dirt or other material in the track assembly. Clean off the tracks before checking clearance.*

- Too little sag in the crawler track can cause excessive component wear. The recommended adjustment can also be too tight causing accelerated stress and wear if ground conditions are wet, marshy or muddy, or if the ground is hard and full of rocks or gravel.



WARNING

The track adjusting mechanism is under very high-pressure. **NEVER** release pressure too suddenly. The track tension grease valve should never be backed off more than 1 complete turn from the fully tightened down position. Bleed off pressure slowly and keep your body away from the valve at all times. If there is problem with the valve threads, the valve might be ejected at high-speed to cause fatal wound.



WARNING

Do not loosen or remove grease fitting (1, Figure 53) until the pressure is entirely bled off by loosening valve (3, Figure 53) slowly.

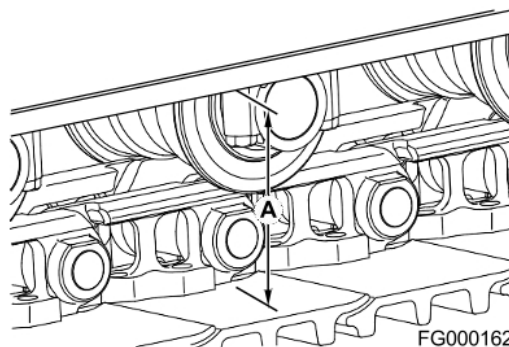

Figure 52

FG000162

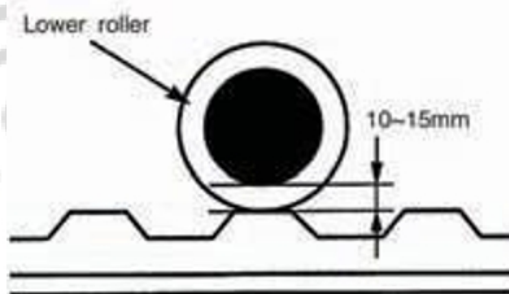
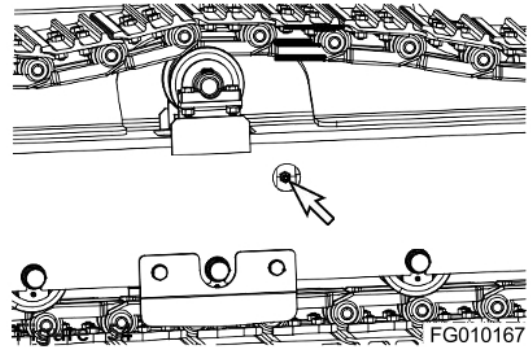

Figure 53

FG007708

How to Adjust Tension

1. Apply grease through grease fitting.
2. Move track forward and backward to distribute grease and readjust tension if necessary.
3. If tension cannot be increased, replace pin and bushing, or, on rubber crawlers, replace cylinder seal or crawler.



To Reduce Tension

1. Loosening the cartridge valve causes grease to drain out and track tension to decrease. Loosen valve slowly a maximum of 1 to turns.
2. When crawler tension is correct, tighten cartridge valve to 59 - 88 Nm / 6-9 kg•m (43 - 65 ft lb)
3. Recheck tension by moving track forward and backward.

Recheck tension and adjust as necessary.

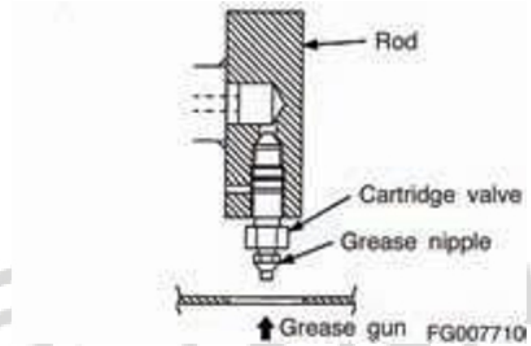

GÜNTE
GROSSMANN

Change Engine Oil Filter

NOTE: Change engine oil and filter after first 50 hours of operation or rebuild, then every 500 thereafter.

WARNING

DO NOT change oil on a hot engine. Allow the engine to cool down before attempting to change the engine oil filter to avoid burns by touching hot engine parts.

1. Position a larger container under the engine. Remove cap (1, Figure 56) and install hose (2) to drain the engine oil. Remove hose (2) and install cap (1).

NOTE: Dispose of drained fluids according to local regulations.

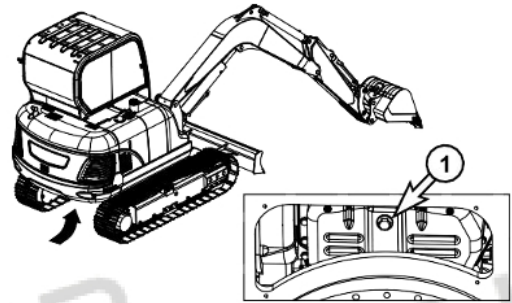

FG010147

Figure 56

2. Replace engine oil filter by using filter wrench. The engine oil filter is a spin-on type. See Figure 57. Remove and discard filter.
3. Install new filter. Apply a small amount of oil around filter gasket. Screw filter on head until gasket contacts head, turn filter 1/2 turn more.
4. Refill the engine with the correct oil through the oil fill port (Figure 57). Refer to the Lubrication Table of this manual for the recommended oil for the operating conditions.

NOTE: See "Fluid Capacities" on page 4-7. for capacity.

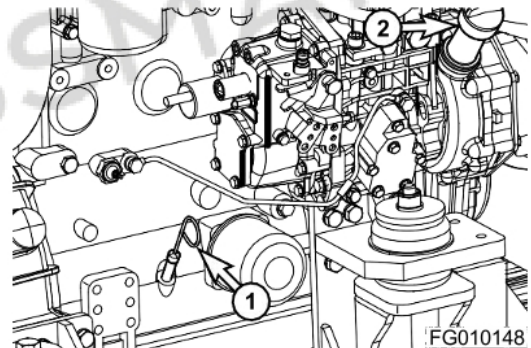

FG010148

Figure 57

5. Start engine. Run engine for five minutes at "LOW IDLE," and check engine oil pressure light.
6. Shut down engine. Look for signs of leaks at filter. Recheck oil level after fifteen minutes.

Replace Outer and Inner Air Cleaner Filters

WARNING

Never clean or attempt to remove air cleaner filter if the engine is running.

NOTE: Replace outer element after cleaning 5 times or every 500 hours of service.

NOTE: Replace inner element whenever a new outer element is installed.

If there is a clogged filter signal on gauge panel, use the following procedure.

1. Open the access door at the hood.
2. Remove evacuator valve (1, Figure 58) and air cleaner cover (2).

NOTE: Inspect evacuator valve seal lips for wear or damage. Replace valve if necessary. Install evacuator valve with lips parallel to the cover.

3. Remove outer filter (3, Figure 59) from air cleaner housing.
4. Clean air cleaner cover and inside of air cleaner housing.
5. Remove inner filter (4, Figure 59).
6. Clean out inside of air cleaner housing. Do not use compressed air to blow out housing.
7. Install new inner filter. Do not clean and reuse inner element.
8. Install new outer filter.
9. Install air cleaner cover and evacuator valve.

NOTE: Make sure that all gaskets and cover are properly installed and seated.

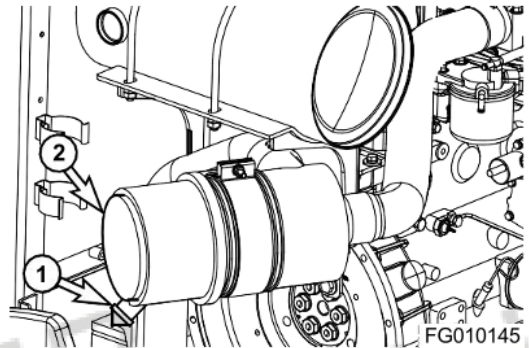

Figure 58

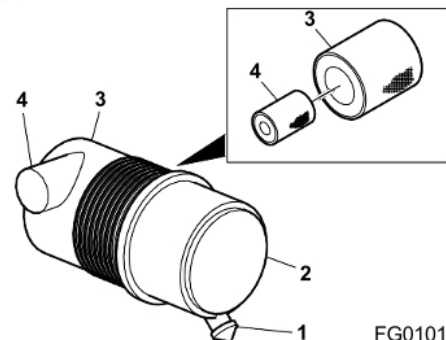

Figure 59

Change Fuel Filter



Exchange filter after waiting for engine to cool. Be careful of fire hazards. Do not smoke.

1. Locate fuel filter inside engine compartment.
2. Position a small container under fuel filter.
3. Unscrew fuel filter from head assembly. Discard fuel filter.

NOTE: *Dispose of drained fluids according to local regulations.*

4. After cleaning filter head, install new fuel filter. Screw filter on head until gasket contacts head, and turn filter 1/2 turn more with a filter wrench.

NOTE: *Coat fuel filter gasket with fuel.*

NOTE: *Fill fuel filter with clean fuel. This will help reduce fuel system priming.*

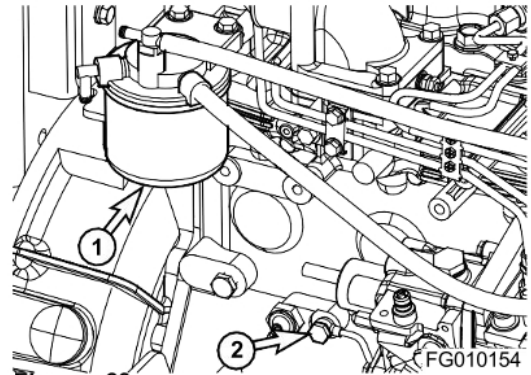

Figure 60

Fuel System Priming

If air remains in the fuel inlet line to the engine, it may cause the engine to run in an abnormal condition. Air may impact the starting capability of the engine, and may also result in surging engine speeds.

If the machine happens to have run out of fuel, or if the fuel filter has been replaced, air may need to be bled using the following procedure:

1. Shut down engine.
2. Fill fuel tank.
3. Loosen plug (2, Figure 60).
4. Turn starter switch to the "I" (ON) position to activate electric fuel pump. This delivers fuel under pressure to each injection nozzle and bleed off pipes of each nozzle holder, and then returns air the fuel tank
5. After air has been bled, tighten plug (2, Figure 60) in fuel prefilter head.
6. Start engine and check fuel system for leaks.

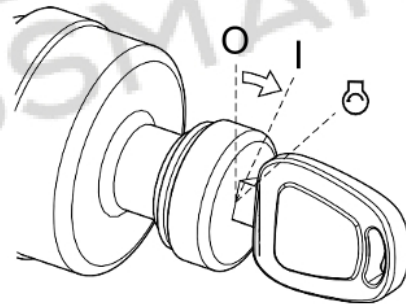

Figure 61

FG000084

Replace Hydraulic Oil Return Filter

NOTE: Change hydraulic oil return filter after first 250 hours of operation or rebuild, and every 500 hours thereafter.

NOTE: If return filter clogged warning light on instrument panel comes "ON" the return filter must be serviced.



WARNING

The hydraulic oil will be hot after normal machine operation. Allow the system to cool before attempting to service any of the hydraulic components.

IMPORTANT

Make sure to clean any dirt or water from the top of the hydraulic tank, especially around the fill port and filter ports.

1. Remove bolts (1), cover (2) and O-ring (3), then spring (4), valve (5) and filter (6).
2. Properly discard filter.
3. Install new filter and a new O-ring. Install valve and spring. Install service cover plate.
4. Run engine for 10 minutes at low idle to purge air from circuit.
5. Shut down engine.
6. Check level in hydraulic oil tank. Add oil if necessary.

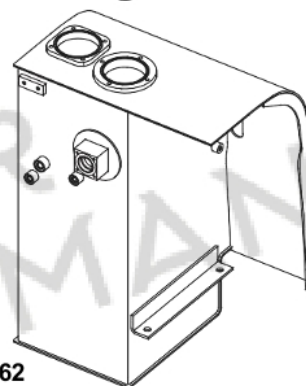
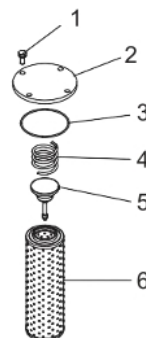

FG012356

Figure 62

Clean Air-conditioning Inner Filter

1. Remove four bolts and filter cover from operator's seat base.



WARNING

All service and inspection of air-conditioning system should be performed with the starter switch in the "O" (OFF) position.

If using compressed air to clean the element, make sure that proper eye protection is worn.

2. Remove filter from seat base. Clean filter using compressed air. If filter is still not clean, replace with a new one.
3. After inserting filter, install cover. Secure cover in place with four screws.

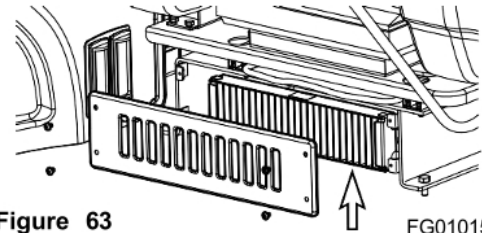
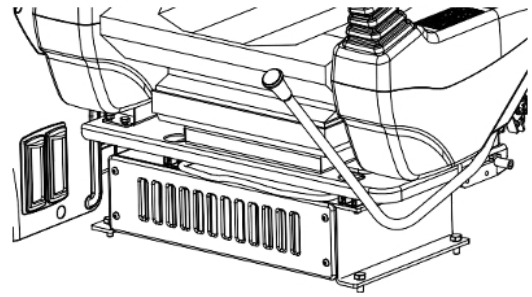

Figure 63

FG010157



GÜNTER
GROSSMANN

1,000 HOUR / 6 MONTH SERVICE

Perform All Daily, 50, 250 and 500 Hour Service Checks

Change Oil in Travel Reduction Device (One on Each Side of Unit)

 **WARNING**

The gear oil is very hot after the machine has been operating. Shut all systems down and allow them to cool. Before fully removing any motor case, inspection port plug, etc., loosen the plug slightly to allow pressurized air to escape.

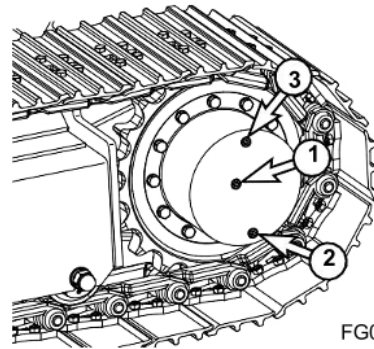

Figure 64

FG010149

NOTE: *Drain oil after first 250 hours of operation or rebuild, and every 1,000 hours thereafter.*

1. Make sure that machine is on firm, level ground.
2. Rotate the track until ports (1 thru 3, Figure 64) are in their proper positions as shown.
3. Place a container under drain plug (2, Figure 64) and remove plugs (1 thru 3) to drain the travel reduction gear oil.

NOTE: *Dispose of drained fluids according to local regulations.*

4. Install drain plug (2, Figure 64). Refill the travel reduction gear case with fluid through fill port (3) until the fluid level is at port (1). Install level plug (1) and fill plug (3).

NOTE: *See "Fluid Capacities" on page 4-7. for capacity.*

5. Repeat this procedure on the other travel reduction device.

Change Air-conditioning Inner Filter

1. Remove four bolts and filter cover from operator's seat base.



WARNING

All service and inspection of air-conditioning system should be performed with the starter switch in the "O" (OFF) position.

If using compressed air to clean the element, make sure that proper eye protection is worn.

2. Remove filter and replace it with a new one.
3. After inserting filter, install cover. Secure cover in place with four screws.

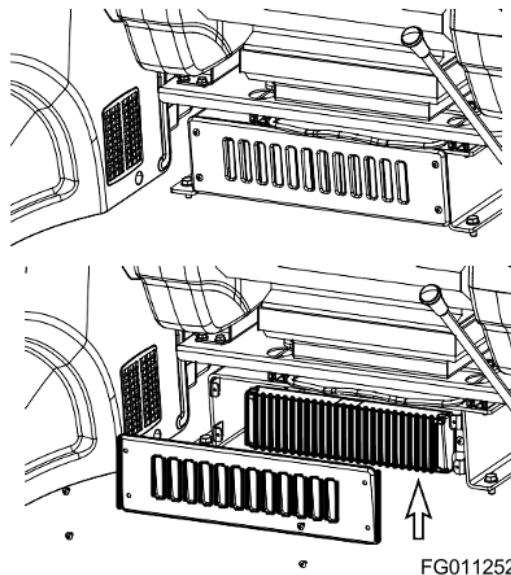

Figure 65

Clean Hydraulic Oil Suction Strainer

NOTE: Clean hydraulic oil suction strainer after first 250 hours of operation or rebuild, then every 1,000 hours thereafter.



WARNING

The hydraulic oil will be hot after normal machine operation. Allow the system to cool before attempting to service any of the hydraulic components.

IMPORTANT

Make sure to clean any dirt or water from the top of the hydraulic tank, especially around the fill port and filter ports.

1. Park machine on firm, level ground.
2. Set safety lever on "LOCK" position.
3. Shut down engine.
4. Release pressurized air from hydraulic tank by rotating breather cap (1, Figure 67).
5. Carefully remove bolts and cover (2, Figure 67) from top of hydraulic oil tank. There is a spring (3) under the cover that will force the cover up.

6. Remove spring (3, Figure 67) and strainer (5), by pulling on rod (4).
7. Clean inside and outside of strainer. Replace strainer if it is broken.
8. Position strainer (5, Figure 67) on boss portion of suction pipe (6).

NOTE: Measurement "A" is 643 mm (25.3 in).

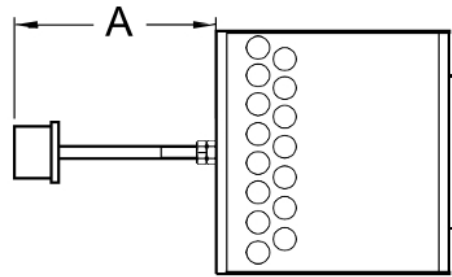

HAOC411L

Figure 66

9. Place spring (3, Figure 67) on rod (4) and assemble cover (2).
10. Check level of hydraulic oil tank. (See page 4-13)

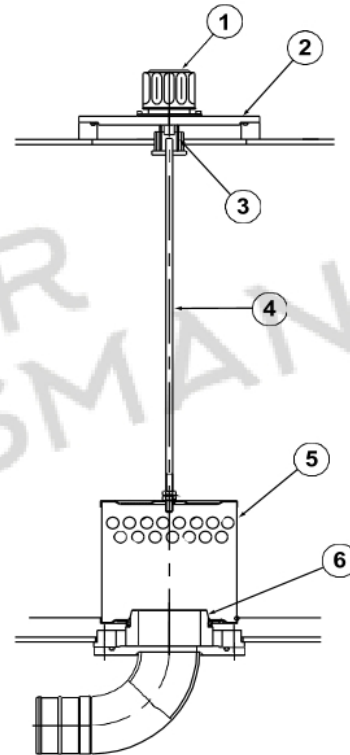

ARO1720L

Figure 67

Change Air Breather Filter

1. Remove the bolt (A) above the breather (1) of the hydraulic oil tank using wrench.
2. Remove the housing (C) of the breather.
3. Change the element (B)
4. Reassemble in reverse order.

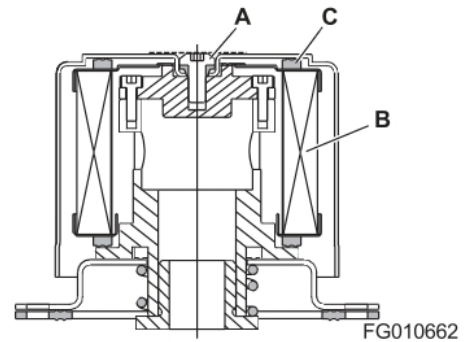

Figure 68

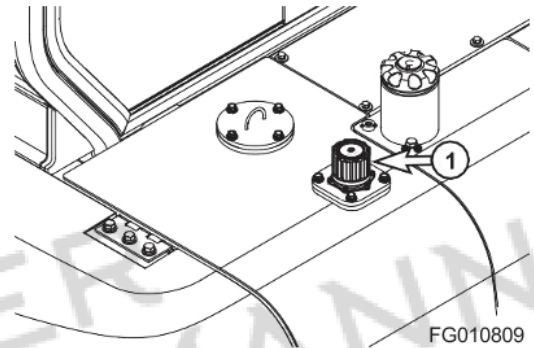

Figure 69

Change Fuel Cap Filter



WARNING

External shock or damages to fuel cap may lead to permanent damage to filter.

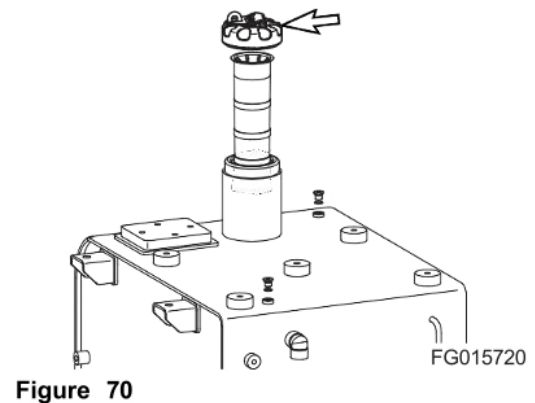

Figure 70

1. See under the fuel cap as shown on (Figure 71). Rotate bolt to CCW direction to loosen.

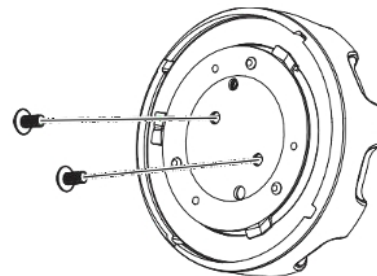
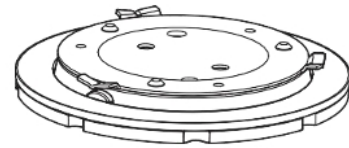

Figure 71

2. After disengaging it as shown on (Figure 72), carefully lay it on floor.



FG015685

Figure 72

3. After disengaging (Figure 72), disengage rubber as shown on (Figure 73).

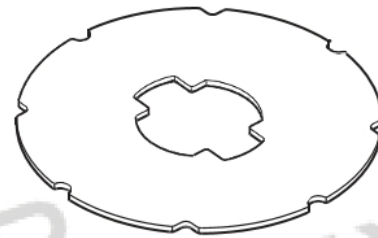

FG015686

Figure 73

4. After disengaging as shown on (Figure 73), you may now exchange it to a new filter as shown on (Figure 74).

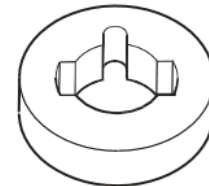

FG015687

Figure 74

5. After exchanging to a new filter, you may now assemble back in reverse order.

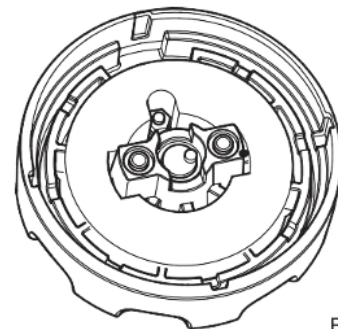

FG015688

Figure 75

Check Air Conditioner Refrigerant

WARNING

Mixing of tobacco smoke and freon is deadly.

Do not smoke while servicing or recharging air - conditioning system.

1. Run engine at about 1800 rpm. Operate for a minimum of ten minutes to stabilize the system.
2. Press the "HI" fan speed switch to set maximum airflow.
3. Put the temperature control switch in maximum cooling position.
4. Press the "Internal Air Circulation" switch.
5. Compare the flow of bubbles in the sight glass of receiver dryer with the drawings in the following table.

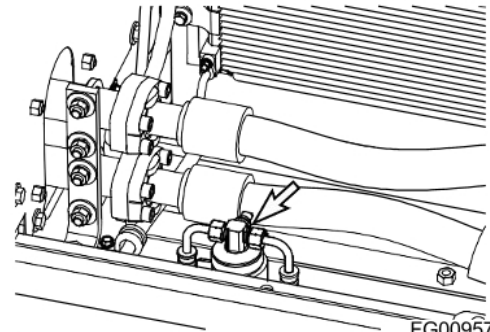





Figure 76

CAUTION

Overfilling refrigerant may cause dangerous high-pressure and poor cooling action; and low refrigerant level may cause compressor damage.

Always maintain refrigerant at normal level.

Amount of Refrigerant	Appearance of the Sight Glass	Solutions
Normal	 <p>Almost clear. Any bubbles disappear.</p>	
High	 <p>No bubbles are seen.</p>	Charge or withdraw the system with the correct amount of HFC- 134a refrigerant.
Low	 <p>A flow of bubbles is visible.</p>	

Check and Adjust Engine **

Contact your nearest *Günter Grossmann* dealer.

Engine dealer for checking and adjusting the following items:

- Engine Compression Pressure.
- Injection Pressure.
- Injection Timing.

2,000 HOUR / YEARLY SERVICE

Perform All Daily, 50, 250, 500 and 1,000 Hour Service Checks

Change Radiator Coolant

WARNING

Allow the engine to cool before releasing the radiator cap. Make sure to loosen the cap slowly to release any remaining pressure.

Radiator cleaning is performed while the engine is running. Take extreme caution when working on or near a running engine. Make sure to lock out and tag the controls notifying personnel that service work is being performed.

Do not remove radiator cap unless it is required. Observe the coolant level in the coolant recovery tank.

1. Slowly open the radiator cap to allow any pressure to escape.
2. Place a container under the radiator and open the drain valve (2, Figure 78).

NOTE: *Dispose of drained fluids according to local regulations.*

3. Remove coolant drain plug (1, Figure 78) from engine.
4. Install drain plug, and close drain valve after coolant has completely drained from system.
5. Fill cooling system with a flushing solution.
6. Run engine at low idle until the coolant temperature gauge reaches the "BLUE ZONE." Run engine for another ten minutes.
7. Allow engine to cool.
8. Drain flushing fluid and fill system with water.
9. Run engine again to allow water to completely circulate.
10. After allowing engine to cool, drain water and fill system with proper antifreeze mixture for ambient temperature. Refer to coolant concentration table. See "Antifreeze Concentration Tables" on page 4-62.
11. Run engine with radiator cap not installed, so all air will be purged from system. Fill radiator to fill neck.
12. Drain and fill radiator coolant recovery tank.



Figure 77

ARO1760L

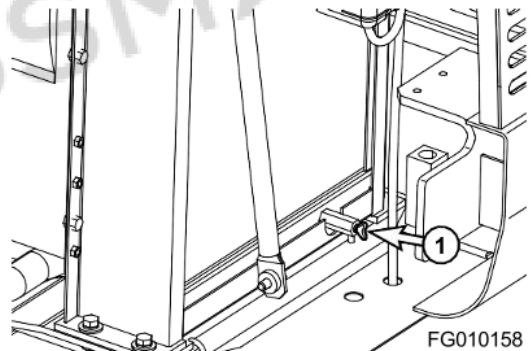

Figure 78

FG010158

Hydraulic Oil Exchange and Suction Strainer Cleaning

WARNING

The hydraulic oil will be hot after normal machine operation. Allow the system to cool before attempting to service any of the hydraulic components.

IMPORTANT

Make sure to clean any dirt or water from the top of the hydraulic tank, especially around the fill port and filter ports.

Hydraulic oil change interval is 2,000 hours, only when *Günter Grossmann* Genuine Oil is used. If another brand of oil is used, guaranteed change interval is 1,000

hours.

NOTE: Based on the type of excavating being completed, the working conditions (extremely hot or dusty) and the extra front end attachments being used (hydraulic breaker, etc.), the hydraulic fluid will need to be changed more frequently.

1. Park machine on firm, level ground. Swing upper structure perpendicular (90°) to tracks. Lower boom and position bucket on ground as shown in Figure 79.
2. Set safety lever on "LOCK" position.
3. Shut down engine.
4. Release pressurized air from hydraulic tank by rotating breather cap (1, Figure 82).

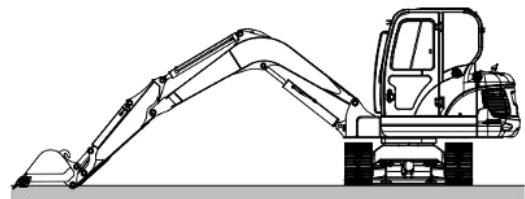

FG010159

Figure 79

5. Drain hydraulic oil from tank into a container capable of holding 97 liters (25.6 U.S. gal.). After draining tank, install drain plug.

IMPORTANT

Be careful of squirting oil when removing drainplug.

NOTE: Used filter and used oil should always be disposed of according to local regulations.

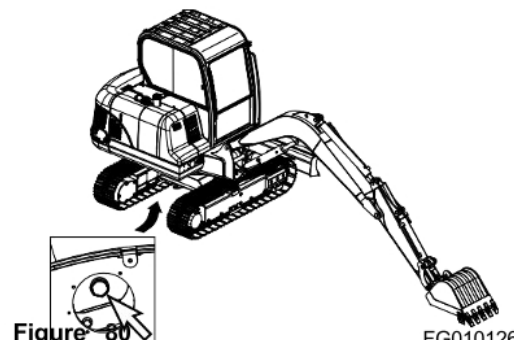
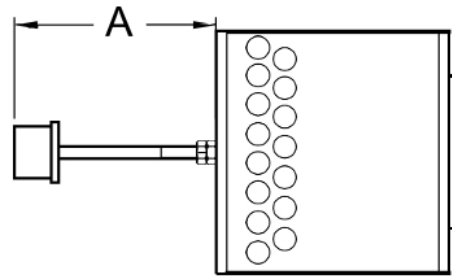

Figure 80

FG010126

6. Carefully remove bolts and cover (2, Figure 82) from top of hydraulic oil tank. There is a spring (3) under the cover that will force the cover up.
7. Remove spring (3, Figure 82) and strainer (5), by pulling on rod (4).
8. Clean inside and outside of strainer. Replace strainer if it is broken.
9. Position strainer (5, Figure 82) on boss portion of suction pipe (6).

NOTE: Measurement "A" is 643 mm (25.3 in).



HAOC411L

Figure 81

10. Fill the hydraulic oil tank. Check level using sight gauge on side of tank.
11. Place spring (3, Figure 82) on rod (4) and assemble cover (2).
12. After replacing and cleaning the hydraulic oil, filter and strainer, vent the system.

IMPORTANT

When the hydraulic breaker is being used, because of the higher heat generated by this unit, use replacement intervals recommended under the "Hydraulic Oil and Filter Service Intervals" on page 3-34.

13. Check level of hydraulic oil tank. (See page 4-13)

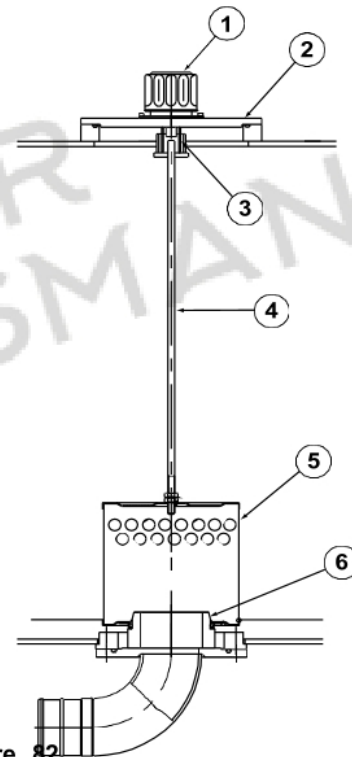

ARO1720L

Figure 82

Check Alternator and Starter**

**These checks need to be completed by an authorized *Günter Grossmann* dealer.

Check All Rubber Antivibration Shock Mounts

**Perform and Record the Results of the
Cycle Time Tests**

**Inspect Machine to Check for Cracked
or Broken Welds or other Structural
Damage**

Check, Adjust Valve Clearance **

Check Head Bolt Torques



**GÜNTER
GROSSMANN**

BOLT AND NUT INSPECTION

Inspect ALL fasteners after the first 50 hours of operation and every 250 hours thereafter. If any are loose or are missing tighten them or install new hardware. Always use a calibrated torque wrench.

IMPORTANT

Always clean fasteners before tightening.

If counterweight is loose, contact a *Günter Grossmann* distributor or sales agent.

NO.	POINT TO BE INSPECTED	BOLT DIA. MM	QTY.	BOLT HEAD SIZE	TORQUE		
					Nm	kg•m	lb ft
1	Joint bolt and nut for engine mounting bracket and frame	14	4	22	176.5	18	130.2
2	Joint bolt for engine mounting bracket and engine	10	10	17	63.7	6.5	47
3	Tightening bolt for hydraulic oil and fuel tank	12	8	19	49	5	36
4	Joint for hydraulic hose pipe	PF 1/4			31 - 37	3.2 - 3.8	23 - 27
		PF 3/8			40 - 48	4.1 - 4.9	30 - 35
		PF 1/2			75 - 91	7.7 - 9.3	56 - 67
		PF 3/4			142 - 171	4.5 - 17.5	105 - 126
		UNF11/16			40 - 48	4.1 - 4.9	30 - 35
		UNF13/16			75 - 91	7.7 - 9.3	56 - 67
5	Tightening bolt for pump	12 (socket)	2	10	107.8	11	79.6
6	Tightening bolt for pump cover	10	12	17	63.7	6.5	47
7	Tightening bolt for swing motor	16	6	24	264	27	83
8	Joint nut with cabin mounting rubber and frame	12	4	19	74.5	7.6	54.8
9	Joint bolt for swing bearing and swivel body	16	24	24	264	27	195
10	Joint bolt for swing bearing and track frame						
11	Tightening bolt for travel motor	14	18	22	176	18	130
12	Tightening bolt for sprocket	14	18	22	176	18	130
13	Tightening nut for upper roller	24	4	36	490	50	361
14	Tightening nut for lower roller	24	20	36	490	50	361
15	Tightening nut for under cover	8	6	13	21.56	2.2	16
		10	28	17	63.7	6.5	47
16	Tightening nut for under counterweight	20	3	30	539	55	397

1. Joint bolt and nut between engine mounting bracket and frame

- Tool: 22 mm ()
- Torque: 18 kg•m (176.5 Nm, 130.2 ft lb)

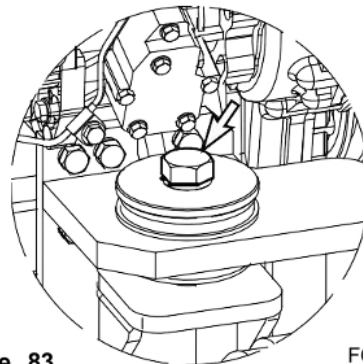



Figure 83

FG010170

2. Joint bolt with engine mounting bracket and engine

- Tool: 17 mm ()
- Torque: 6.5 kg•m (63.7 Nm, 47 ft lb)

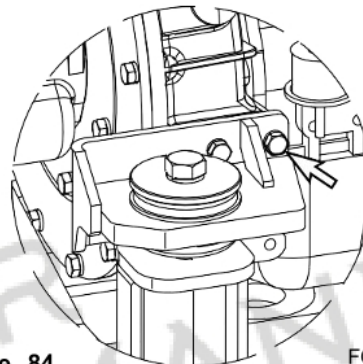



Figure 84

FG010169

3. Tightening bolt for hydraulic oil and fuel tank

- Tool: 19 mm ()
- Torque: 5 kg•m (49 Nm, 36 ft lb)

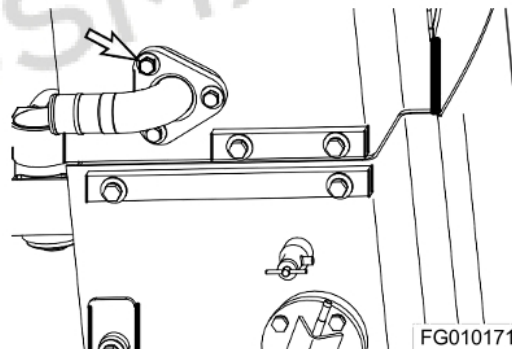



Figure 85

FG010171

5. Tightening bolt for pump

- Tool: 10 mm ()
- Torque: 11 kg•m (107.8 Nm, 79.6 ft lb)

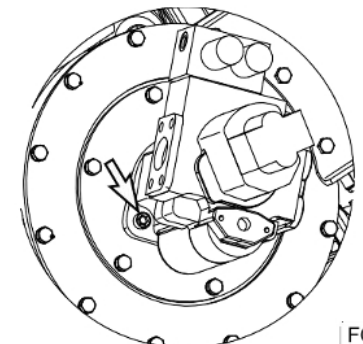

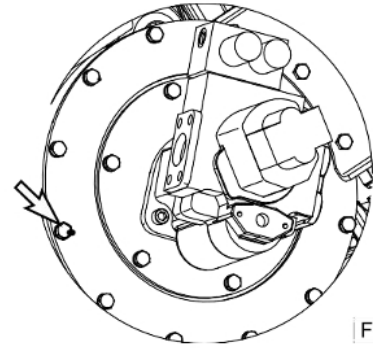

Figure 86

FG010173

6. Tightening bolt for pump cover

- Tool: 17 mm ()
- Torque: 6.5 kg•m (63.7 Nm, 47 ft lb)



FG010172

Figure 87

7. Tightening bolt for swing motor

- Tool: 24 mm ()
- Torque: 27 kg•m (264 Nm, 83 ft lb)

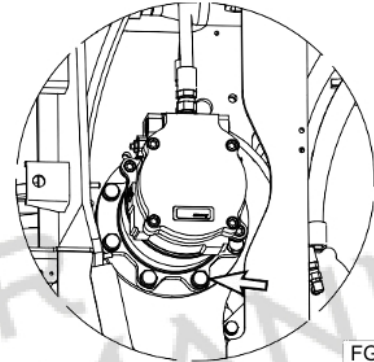

FG010175

Figure 88

8. Joint nut for cabin mounting rubber and frame

- Tool: 19 mm ()
- Torque: 7.6 kg•m (74.5 Nm, 54.8 ft lb)

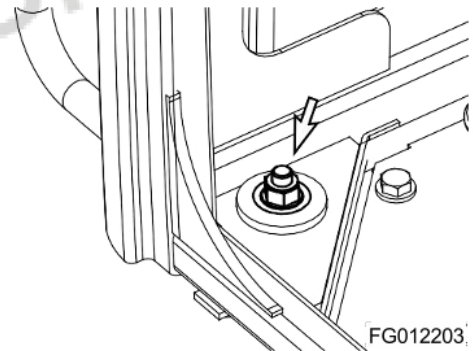

FG012203

Figure 89

9. Joint bolt for swing bearing and swivel body

- Tool: 24 mm ()
- Torque: 27 kg•m (264 Nm, 195 ft lb)

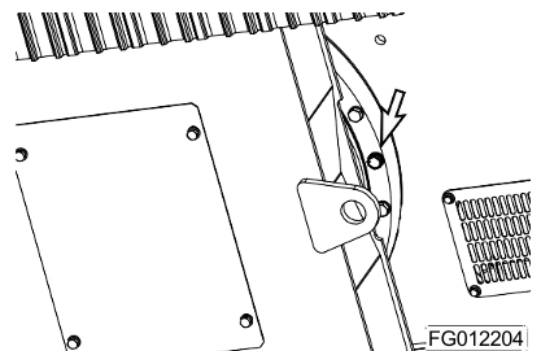

FG012204

Figure 90

10. Joint bolt with swing bearing and track frame

- Tool: 24 mm ()
- Torque: 27 kg·m (264 Nm, 195 ft lb)

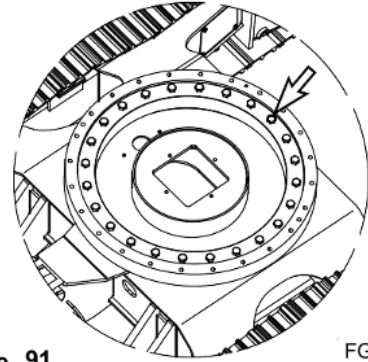



Figure 91

FG010177

11. Tightening bolt for travel motor

- Tool: 22 mm ()
- Torque: 18 kg·m (176 Nm, 130 ft lb)

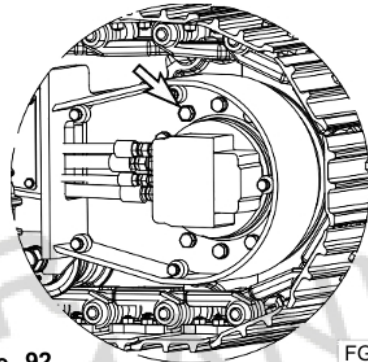



Figure 92

FG010178

12. Tightening bolt for sprocket

- Tool: 22 mm ()
- Torque: 18 kg·m (176 Nm, 130 ft lb)

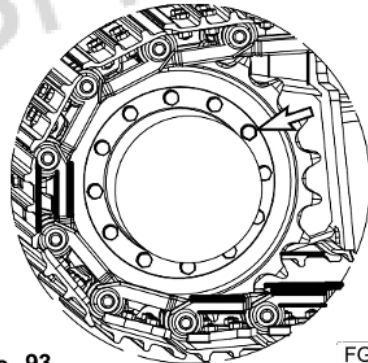



Figure 93

FG010179

13. Tightening nut for upper roller

- Tool: 36 mm ()
- Torque: 50 kg·m (490 Nm, 361 ft lb)

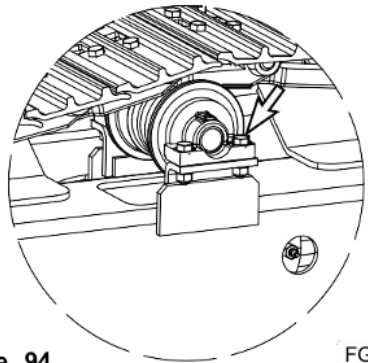



Figure 94

FG010180

14. Tightening nut for lower roller

- Tool: 36 mm ()
- Torque: 50 kg•m (490 Nm, 361 ft lb)

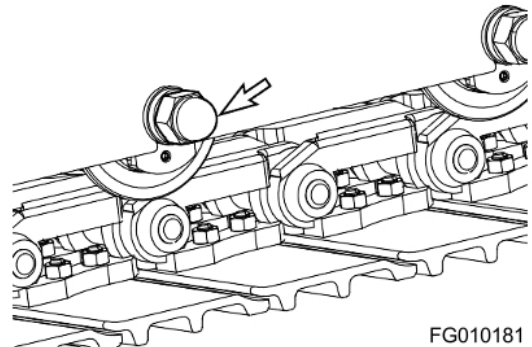



Figure 95

FG010181

15. Tightening bolt for under cover

- Tool: 13 mm ()
- Torque: 2.2 kg•m (21.56 Nm, 16 ft lb)
- Tool: 17 mm ()
- Torque: 6.5 kg•m (63.7 Nm, 47 ft lb)

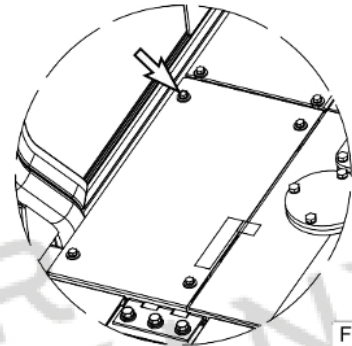



Figure 96

FG010182

16. Tightening bolt for counterweight

- Tool: 30 mm ()
- Torque: 55 kg•m (539 Nm, 397 ft lb)

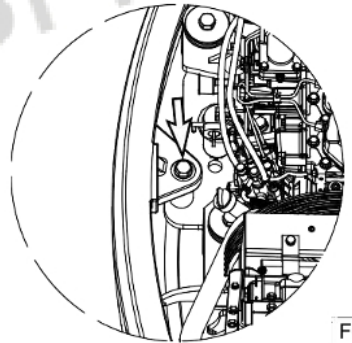

Figure 97

FG010183

BUCKET

Bucket Tooth Replacement



WARNING

Due to the possibility of flying metal objects, always wear safety helmet, protective gloves and eye protection when changing bucket teeth.

Curl the bucket upwards and place the round rear surface of the bucket firmly on the ground. Shut the engine off and lock out the hydraulic controls before working on the bucket.

NOTE: *These instructions are only for Günter Grossmann OEM buckets. If you are using other manufacturers buckets, refer to their specific instructions.*

1. On a routine basis, inspect bucket teeth to make sure that tooth wear or breakage has not developed. Do not allow replaceable bucket teeth to wear down to a point that bucket adapter is exposed. See Figure 98, Figure 99.
2. To replace a tooth, use a hammer (1, Figure 100) and punch (2) to drive locking pin (4, Figure 101) and lock rubber (3) out of tooth adapter.
3. Once worn tooth has been removed, use a putty knife to scrape adapter as clean as possible.
4. Slide new tooth into position and insert lock washer.
5. Insert locking pin into tooth and with a hammer, drive pin in until lock washer seats in locking groove.

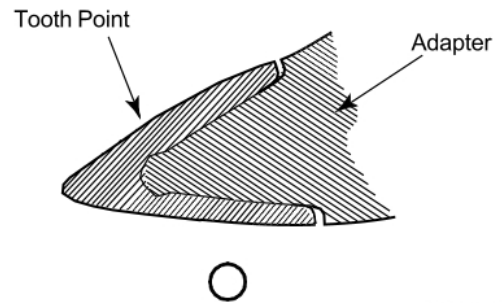

Figure 98

FG010724

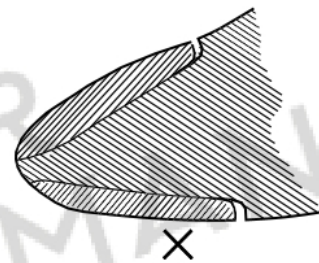

Figure 99

FG010083

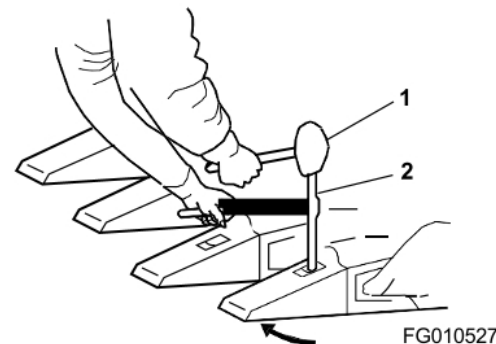
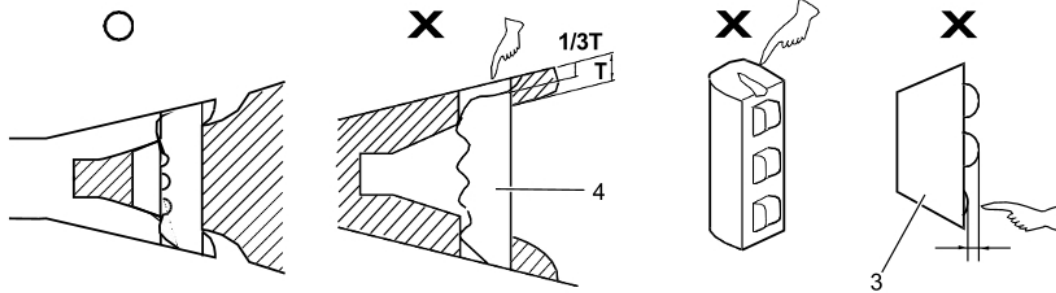

Figure 100

FG010527



FG012221

Figure 101

Inspect locking pin assembly and replace it if the following conditions exist:

1. The locking pin is too short when both surfaces are aligned.
2. The rubber has been torn and bosses of the steel balls are liable to slip off.
3. Pressing steel ball causes the boss to go inside.

Bucket O-ring Replacement



WARNING

Due to possibility of flying metal objects, always wear safety helmet, protective gloves and eye protection when changing pins.

1. Inspect bucket O-rings on a routine basis. If worn or damaged, replacement is necessary.

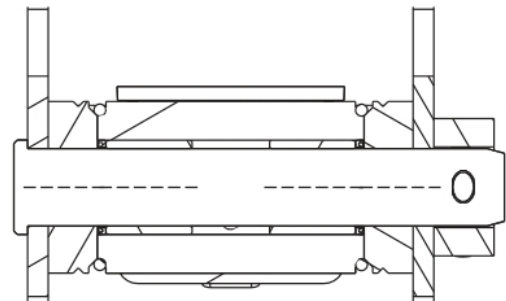

FG012378

Figure 102

- Roll old O-ring (1, Figure 103) onto boss (2) around bucket pin (3). Remove bucket pin and move arm or bucket link (4) out of way.

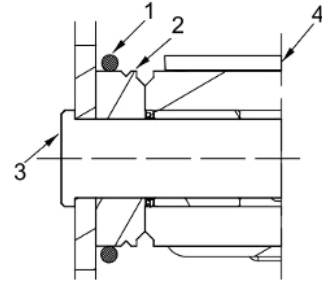

Figure 103

FG011218

- Remove old O-ring and temporarily install new O-ring (1, Figure 103) onto bucket boss (2). Make sure that O-ring groove on both bucket link (4) and boss have been cleaned.
- Realign arm or link with bucket pinhole and insert bucket pin (3, Figure 103).

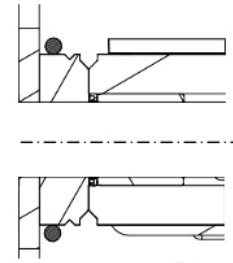

Figure 104

FG010164

- Roll new O-ring (1, Figure 103) into O-ring groove.

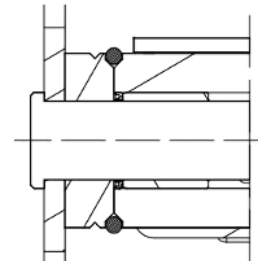

Figure 105

FG010165



GÜNTHER
GROSSMANN

ELECTRICAL SYSTEM

NOTE: *Never disassemble electrical or electronic parts.
Consult with a Günter Grossmann distributor or
sales agency before servicing.*

Battery



WARNING

Battery electrolyte contains sulfuric acid and can quickly burn the skin and eat holes in clothing. If you spill acid on yourself, immediately flush the area with water.

Battery acid could cause blindness if splashed into the eyes. If acid gets into the eyes, flush them immediately with large quantities of water and see a doctor at once.

If you accidentally drink acid, drink a large quantity of water or milk, beaten egg or vegetable oil. Call a doctor or poison prevention center immediately.

When working with batteries, always wear safety glasses or goggles.

Battery generates hydrogen gas, so there is a danger of an explosion. Do not bring lighted cigarettes near the battery, or do anything that will cause sparks.

Before working with batteries, shut down engine and turn the starter switch to the "O" (OFF) position.

Avoid short-circuiting the battery terminals through accidental contact with metallic objects, such as tool.

When removing or installing, check which is the positive (+) terminal and negative (-) terminal.

When removing the battery, first disconnect the negative (-) terminal. When installing the battery, first connect the positive (+) terminal.

If the terminals are loose, there is a danger that defective contact may generate sparks that will cause an explosion. When installing the terminals, install them tightly.

Batteries in Cold Weather

In colder weather a greater drain is placed on the batteries when they are used for the preheat cycle and when starting a cold engine. Battery performance decreases as the temperature gets lower.

In extremely cold weather, remove batteries at night and move them to a warm location. This will help to keep them at a higher power level.

Inspection of Battery Electrolyte Level

This machine has two maintenance free batteries. They never require the addition to water.

When the charge indicator becomes transparency, it means low electrolyte state because of the leakage or charging system error. Determine the cause of problem and replace the batteries immediately.

Check Charging State

Check charging state through the charging indicator.

- GREEN: Sufficiently charged.
- BLACK: Insufficient charged.
- TRANSPARENT: Replace battery.

Check the Battery Terminals

Be certain that battery is held securely in its compartment. Clean the battery terminals and the battery cable connectors. A solution of baking soda and water will neutralize acid on the battery surface, terminals, and cable connectors. Petroleum jelly or grease can be applied to the connectors to help prevent corrosion.

Battery Replacement

When the charging indicator indicates transparency state, replace the battery. The batteries should always be replaced in pairs.

Using an old battery with a new one will shorten the life span of the new battery.

Fuses

1. The fuses in the fuse box are used to protect the various electrical circuits and their components from being damaged. See Figure 108. The fuses used are standard automotive type fuses.
2. The section on "Fuse Identification" on page 4-59, lists the circuits and the fuse amperage required for each circuit. If a fuse blows, determine the cause and repair any faults or failures.
3. Do not insert a higher amperage fuse into a lower amperage slot. Serious damage to the electrical components or fire can result.

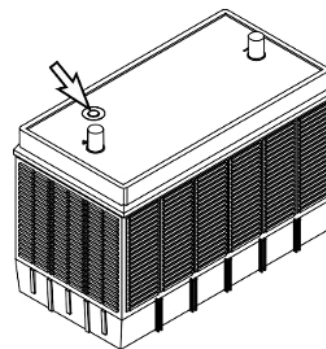

Figure 106

FG010161

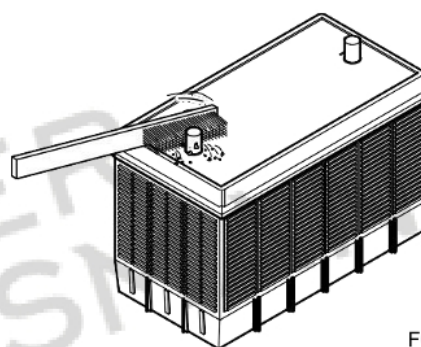

Figure 107

FG010162

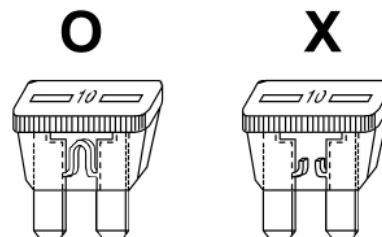

Figure 108

HAOC670L



CAUTION

Before replacing a fuse, be sure to turn starter switch to "O" (OFF) position.

Fuse Boxes

There are two fuse boxes (Figure 109) on the left side of the heater box. The fuses prevent electrical devices from overloading or shorting.

A decal attached inside the fuse box's cover indicates the function and amperage of each fuse.

Spare fuses are mounted on the inside of fuse box's cover. (One each of a 10A, 15A, 20A and 30A.)

Change a fuse if the element separates. If the element of a new fuse separates, check the circuit and repair the circuit.

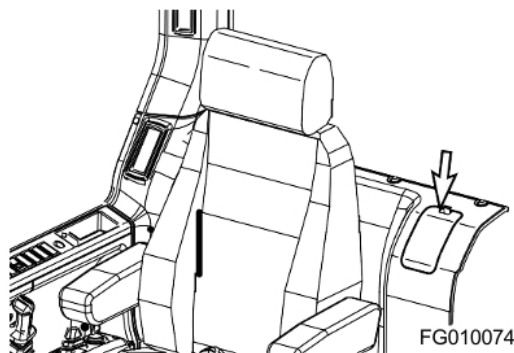

Figure 109

CAUTION

Always replace fuses with the same type and capacity fuse that was removed. Otherwise, electrical damage could result.

Fuse Identification

No.	Fuse Box One	
	Name	Capacity
1	Beacon (Optional), Travel Alarm (Optional) Quick Clamp (Optional),	10A
2	Hi Speed, Pilot Cut Off, Cabin Light (Optional)	10A
3	Wiper Motor, Windshield Washer	10A
4	A/C Panel, Stereo Control Unit,	10A
5	Gauge Panel, Pilot Buzzer	10A
6	Horn, Breaker, 2-Way	10A
7	EGR Valve	10A
8	Starter Switch	10A
9	Can Checker	15A
10	Cigar Lighter	15A
11	Condenser Fan, Compressor	20A
12	A/C Unit	20A
13	Fuel Pump, Room Light	20A
14	Working Light, Headlight	30A

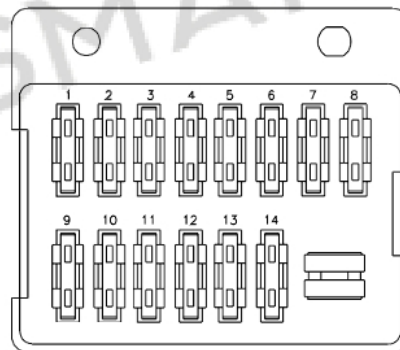

FG007491

Figure 110

ENGINE COOLING SYSTEM

General

Keeping an engine's cooling system in peak operating condition can have many benefits in keeping a machine in good operating condition. A properly functioning cooling system will; improve fuel efficiency, reduce engine wear, and extend component life.

Always use distilled water in the radiator. Contaminants in tap water neutralize the corrosion inhibitor components. If tap water must be used, it should not exceed 300 ppm hardness, or contain more than 100 ppm of either chloride or sulfate. Water that has been treated with a water softener also contains salt that will cause corrosion of components. Water from creeks and stagnant pools usually contains dirt, minerals and/or organic material that are deposited in the cooling system and impair cooling efficiency. Distilled water is the best.

Engine overheating is often caused by bent or clogged radiator fins. The spaces between the fins can be cleaned by use of air or water under pressure. When straightening bent fins, use care not to damage the tubes or break the bond between the fins and the tubes.



WARNING

Pressure at air nozzle must not exceed 2.1 kg·cm² (30 psi). Always wear goggles when using compressed air.

Do not pour cold water into radiator when engine is very hot and water level is below the top of the tubes. Such action could result in damage to engine cylinder heads.

Heavy duty diesel engines require a balanced mixture of water and antifreeze. Drain and replace the mixture every year or 2,000 hours of operation, whichever comes first. This will eliminate buildup of harmful chemicals.

Antifreeze is essential in any climate. It broadens the operating temperature range by lowering the coolant's freezing point and by raising its boiling point. Do not use more than 50% antifreeze in the mixture unless additional freeze protection is required. Never use more than 68% antifreeze under any condition.

Types of Antifreeze

There are two main classifications of antifreeze available on the market today.

1. Ethylene Glycol - Günter Grossmann Genuine Antifreeze Solution
(for all seasons)
2. Propylene Glycol - Günter Grossmann Genuine Antifreeze Solution
(for all seasons)

Ethylene glyco has been on the market for many years. Its chemical properties do not provide the improved corrosion resistance that propylene glycol does. Ethylene glycol is also very hazardous to the environment, people and animals. *Günter Grossmann* recommends that ethylene glycol be replaced with propylene glycol.

The newer propylene glycol antifreeze comes in many different colors. Some of the colors are pink, red, orange and yellow. There are even some that come in a blue-green color. The blue-green color makes it very difficult to tell the difference of what type of antifreeze is in a cooling system. The colors are only a dye added to the clear antifreeze. Do not rely on color. Keep careful machine records of what brand and type of antifreeze is used in the unit. If you are unsure of what type of antifreeze is in the system, drain and flush the system.



CAUTION

Do not mix the ethylene glycol and propylene glycol solutions. If these two chemicals are mixed, undesirable chemicals may be formed, which damages the equipment.

Do not mix up the solutions from different manufacturers. Otherwise, the performance may be deteriorated. It is recommended to use the *Günter Grossmann* Genuine Product.

In the regions under extreme weather, the user should determine the performance of the coolant suitable for the weather condition and decide the replacement cycle.

Antifreeze Concentration Tables

Ethylene Glycol - Günter Grossmann Genuine Antifreeze Solution (for all seasons)(2,000 Hour / Yearly)		
Ambient Temperature	Cooling Water	Antifreeze
-10°C (14°F)	80%	20%
-15°C (5°F)	73%	27%
-20°C (-4°F)	67%	33%
-25°C (-13°F)	60%	40%
-30°C (-22°F)	56%	44%
-40°C (-40°F)	50%	50%

Propylene Glycol - Günter Grossmann Genuine Antifreeze Solution (for all seasons)(2,000 Hour / Yearly)		
Ambient Temperature	Cooling Water	Antifreeze
-10°C (14°F)	78%	22%
-15°C (5°F)	71%	29%
-20°C (-4°F)	65%	35%
-25°C (-13°F)	59%	41%
-30°C (-22°F)	55%	45%
-40°C (-40°F)	48%	52%

NOTE: *Mixing ratio is for reference purpose only, and is not an absolute standard.*

NOTE: *Replacement cycle of the Günter Grossmann Genuine Product is 2,000 hours or one year.*

FUEL TRANSFER PUMP (OPTIONAL)



WARNING

Do not dry operate fuel pump for more than fifteen seconds.

- Cooling and lubrication of pump is achieved by fuel passing through pump. If pump is dry operated, heat generated by moving parts will cause damage to pump rotors, vanes and seals. To prevent unnecessary wear and/or damage to pump do not dry operate fuel pump for more than fifteen seconds.

Do not operate pump for more than fifteen minutes at a time.

- Continuous usage of pump over recommended time interval will cause overheating of motor and will result in motor damage.

Do not use fueling pump for other types of fuel or fluids. (Use only diesel.)

- Do not use fueling pump for other types of fuel which have a low flash point.
- Do not use fueling pump for fuel contaminated with water or high humidity. Moisture in pump mechanism can cause rust and create pump failure.

Always operate pump using strainer installed on inlet hose. This will prevent any foreign materials from being introduced into pump. Always maintain pump and all of its components in a clean condition.

- If dirt or other foreign materials enter pump, it can become lodged between the rotor and/or vanes and generate heat which can cause pump damage.
- Do not remove strainer or use a strainer with larger mesh to increase flow of fuel.

Be careful not to overfill or spill fuel.

Make sure direction of check valve is in line with flow direction of fuel.

If any pump parts or components become lost, damaged or inoperable, immediately replace it with a new ones.

IMPORTANT

If there are any sign of leakage while operating transfer pump, inspect the following components to prevent any fires or hazardous fuel spills.

- Check all hoses leading to and from the transfer pump.
- Check all hose clamps.
- Check transfer pump inlet port.

The transfer pump is used to transfer fuel from a refueling source to the fuel tank. A check valve is installed in the inlet hose to prevent fuel from flowing back from fuel tank to source. A strainer is installed in inlet hose to prevent any foreign material from being introduced into transfer pump or fuel tank.

A thermal limiter, built into the motor, will automatically shut off power if motor is overheating to protect it from being damaged.

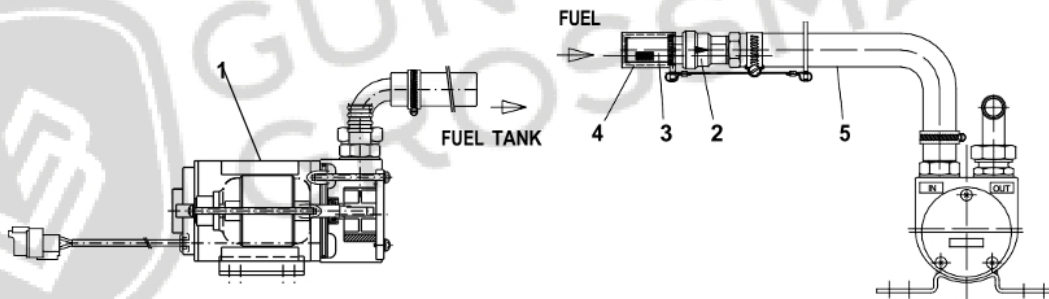

Figure 111

FG000161

Reference Number	Description
1	Body
2	Check Valve
3	Strainer

Reference Number	Description
4	Strainer Cap
5	Inlet Hose

LONG TERM STORAGE

Perform the following if storing the excavator for more than one month.

Conditions	Maintenance Required
Cleaning	Pressure wash the undercarriage and track assemblies. Inspect for damage or loose or missing parts.
Lubrication	Perform all daily lubrication procedures.
	Apply a coating of light oil to the exposed plated metal surfaces, such as hydraulic cylinder rods, etc.
	Apply a coating of light oil to all the control linkages and control cylinders (control valve spools, etc.).
Battery	Remove battery from the excavator or remove battery leads from the battery to fully charge and store.
Cooling System	Inspect the coolant recovery tank to make sure that antifreeze level in the system is at the correct level.
	Every 90 days, use a hydrometer to measure the protection level of the coolant. Refer to the antifreeze/coolant protection chart to determine the amount of protection the cooling system requires. Add coolant as required.
Hydraulic System	Once a month, start the engine and follow the "Hydraulic Oil Warm-up" procedures listed in this manual.



GÜNTHERMANN
GROSSMANN

NOTE: See "Operation Under Unusual Conditions" on page 3-40 for other recommendations.

Conditions	Maintenance Required
Operating in mud, water or rain.	Perform a walk around inspection to check for any loose fittings, obvious damage to the machine or any fluid leakage.
	After completing operations, clean mud, rocks or debris from the machine. Inspect for damage, cracked welds or loosened parts.
	Perform all daily lubrication and service.
	If the operations were in salt water or other corrosive materials, make sure to flush the affected equipment with fresh water.
Operating in an extremely dusty or hot environment.	Clean the air intake filters on a more frequent basis.
	Clean the radiator and oil cooler fins to remove embedded dirt and dust.
	Clean the fuel system intake strainer and fuel filter more frequently.
	Inspect and clean as required the starter and alternator.
Operating in rocky terrain.	Check the undercarriage and track assemblies for damage or excessive wear.
	Inspect for loose or damaged fittings or bolts.
	Relax track tension.
	On a more frequent basis, inspect the front end attachments for damage or excessive wear.
	Install top and front guard as required for protection against falling rocks.
Operating in extreme cold.	Use the proper fuel for the temperature conditions.
	Using a hydrometer, check the antifreeze to make sure that it is providing the proper cold weather freeze protection.
	Verify the condition of the batteries. In extremely cold weather remove batteries at night and store them in a warmer area.
	Remove mud buildup as soon as possible to prevent it from freezing to the undercarriage and causing damage.

Transportation

Obey all local, state or federal regulations for the transportation of the excavator. If unsure of regulations check with local authorities.

Check the intended route for road width, overhead clearances, weight restrictions, and traffic control regulations. Special approval or permits may be required.

LOADING AND UNLOADING

Warning for Counterweight and Front Attachment Removal



DANGER

Günter Grossmann warns any user, that removal of the counterweight from the machine, front attachment or any other part, may affect the stability of the machine. This could cause unexpected movement, resulting in death or serious injuries. *Günter Grossmann* is not liable for any misuse.

Never remove counterweight or front attachment unless the upper structure is in-line with the lower structure.

Never rotate the upper structure once the counterweight or front attachment has been removed.

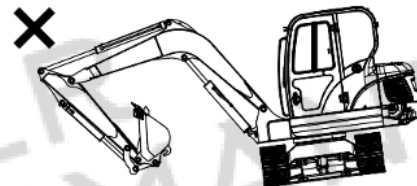

FG010276

Figure 1

WARNING

When transporting the machine, know the width, height, length and weight.

Loading or unloading the machine can be a dangerous operation. Make sure to run the engine at the lowest speed setting, and travel at the slowest speed possible.

Make sure that ramp being used can handle the weight of the machine. If required, add blocking under the ramp for additional support.

Make sure that ramp surface is free of grease or mud that could cause the machine to slip or slide.

Make sure that trailer is parked on firm, level ground before attempting to load/unload the excavator.

If it is required to turn the machine while it is on the trailer, make sure to do this at the slowest engine and travel speeds possible.

Make sure to secure the excavator onto the trailer as required by local transportation laws.

Total Height	Total Width	Total Length	Weight	Remarks
2,580 mm (8' 6")	1,860 mm (6' 1")	5,850 mm (19' 2")	5.5 metric tons (6.1 tons)	3 m (9' 10") Boom 1.6 m (6' 11") Arm 380 G Shoe

1. Make sure that trailer is parked on firm, level ground. See Figure 2.
2. Make sure that ramps that are being used are designed to handle the weight of the excavator. If required, add blocking under the ramp to provide additional support.
3. The ramp angle should be less than or not exceeding a 15° angle. Ramps steeper than this may cause a problem when loading or unloading.

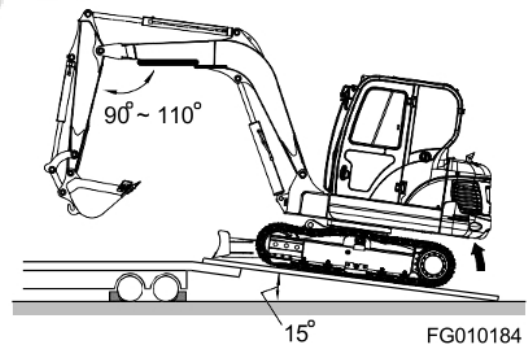
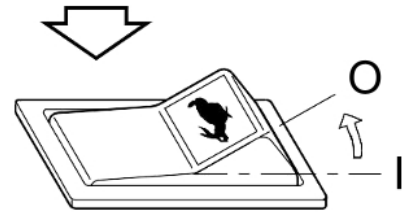

Figure 2

4. Set the travel speed selector switch to "O" (OFF) position. See Figure 3.
5. Set engine speed to "LOW IDLE."



FG008127

Figure 3

6. If the machine is equipped with work equipment, set the work equipment at the front, and travel forward to load it.

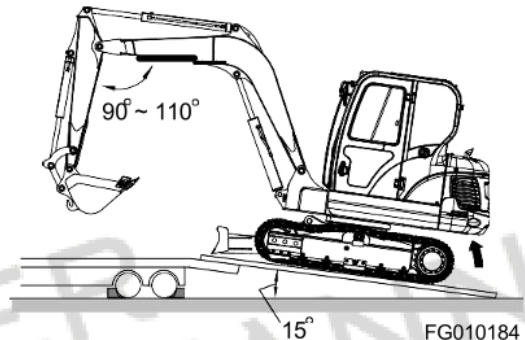

FG010184

Figure 4

7. The unit does not require disassembly for normal over-the-road transportation. If the boom and arm need to be removed, the counterweight will place more weight on the rear of the machine. Make sure to back the excavator onto the trailer so the counterweight end of the excavator is positioned on the ramp first. See Figure 5.

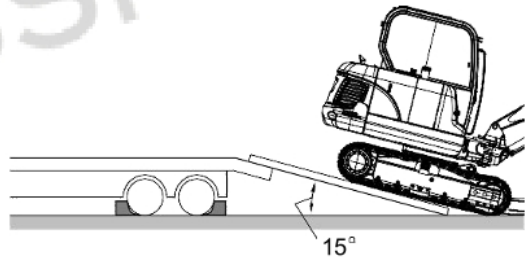

FG010712

Figure 5

8. Extend bucket and arm cylinders to maximum length and then lower the boom slowly.

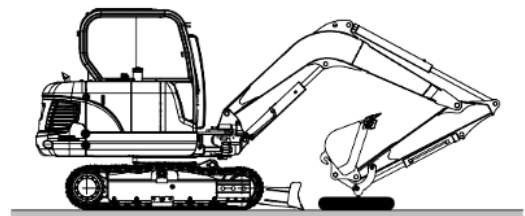

FG011291

Figure 6

- Set safety lever on "LOCK" position.

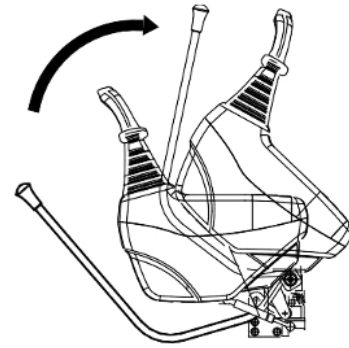

FG010050

Figure 7

- Shut down engine by turning key to "O" (OFF) position (Figure 8).
- Remove key from starter switch.

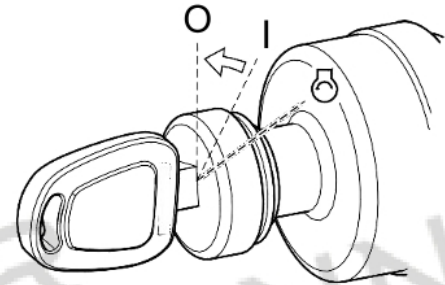

FG008623

Figure 8

- Make sure to secure the excavator onto the trailer before transporting. Place blocking (1, Figure 9) in front of and behind each track. Use chains or cable tie-downs (2) as required by local transportation laws.
- Refer to the Dimensions for Transportation table and drawing for overall machine height and width measurements. Make sure to position the excavator as shown. If not transported in this position, the height measurements may be different.

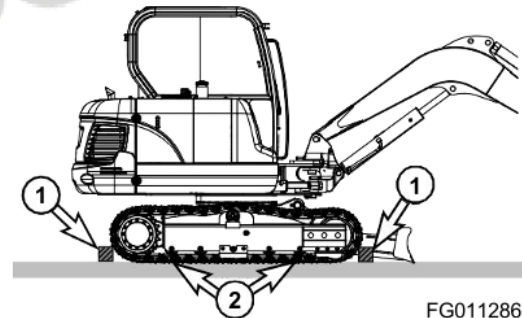

FG011286

Figure 9

LIFTING WITH SLING



WARNING

Improper lifting can allow load to shift and cause injury or damage.

1. Refer to "Specification" on page 7-1 of this manual for information on weight and dimensions.
2. Use properly rated cables and slings for lifting.
3. Position machine for a level lift.
4. Lifting cables should have a long enough length to prevent contact with the machine. Spreader bars may be required.

NOTE: *If spreader bars are used, be sure that cables are properly secured to them and that angle of the cables is factored into the lift strength.*

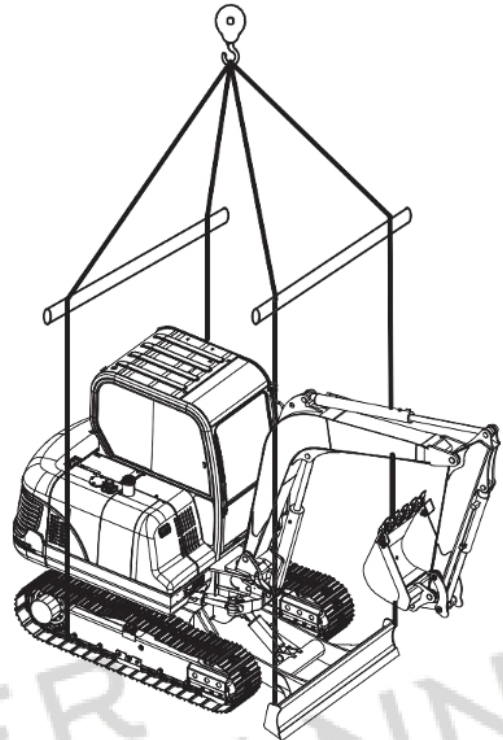

Figure 10

FG012290



GÜNTER
GROSSMANN



GÜNTER
GROSSMANN

Troubleshooting

Anytime that a malfunction occurs, take immediate corrective action. Check for and investigate the cause of the malfunction. A schedule maintenance program can prevent malfunctions from occurring by doing preventative maintenance. A systematic approach should be taken to troubleshooting, since several overlapping malfunctions may give the appearance of a problem that does not exist. If cause for the malfunction cannot be determined, contact your *Günter Grossmann* distributor.

Never perform an adjustment of or disassembly of, hydraulic components, electrical and electronic components, without first consulting a *Günter Grossmann* distributor.

ELECTRICAL SYSTEM

Problem	Cause	Remedy
Battery will not hold a charge.	Low battery power.	Clean and retighten.
	Alternator belt loose or bad.	Tighten or replace belt.
	Loose or corroded terminals.	Tighten or replace as required.
	Alternator faulty.	Repair or replace as required.
Low battery power.	Internal battery short.	Replace battery.
	Short-circuit in wiring.	Repair as required.
Engine speed is not controllable.	Speed control dial failed.	Replace control dial.
	Throttle controller failed.	Replace controller.
	Speed control motor failed.	Repair or replace as required.
	Blown fuse.	Replace fuse.
	Wiring harness damaged.	Repair or replace as required.
	Connector failed.	Repair or replace as required.
Power mode selector does not work.	Blown fuse.	Replace fuse.
	Power mode selector switch failed.	Replace switch.
	Connector failed.	Replace connector.
	Wiring harness damaged.	Repair or replace as required.
	e-EPOS controller failed.	Repair or replace as required.

Problem	Cause	Remedy
Working mode selector does not work.	Blown fuse.	Replace fuse.
	Working mode selector switch.	Replace switch failed.
	Connector failed.	Replace connector.
	Wiring harness damaged.	Repair or replace as required.
	e-EPOS controller failed.	Repair or replace as required.

ENGINE

Problem	Cause	Remedy
Starter does not operate.	Low battery power.	Charge battery.
	Poor terminal contact.	Clean and tighten connections.
	Starter switch failed.	Replace switch.
	Starter relay failed.	Replace relay.
	Starter controller failed.	Replace controller.
	Wiring harness faulty.	Replace harness.
	Battery relay failed.	Replace relay.
	Blown fuse.	Replace fuse.
Starter engages, engine does not start.	Fuel gelled in cold weather.	Replace fuel.
	Fuel filters plugged.	Replace filters.
	Water or dirt in fuel system.	Clean system and add new fuel.
	Air in fuel system.	Purge air from system.
	Engine stop control failed.	Contact your <i>Günter Grossmann</i> dealer.
	Engine stop relay failed.	Replace relay.
	Blown fuse.	Replace fuse.
Engine starts, runs only at low speed or shuts down.	Engine oil viscosity incorrect.	Change oil.
	Clogged or dirty fuel injectors.	Clean injectors.
	Fuel filters plugged.	Replace filters.

Problem	Cause	Remedy
Engine knocks, runs unevenly or surges.	Low engine oil.	Refill.
	Plugged air intake system.	Clean system and replace filter.
	Injection pump out of adjustment.	Contact your <i>Günter Grossmann</i> dealer.
	Plugged fuel filter.	Replace fuel filter.
	Water or dirt in fuel system.	Clean system and add new fuel.
	Clogged or dirty fuel injectors.	Clean injectors.
Engine has poor power.	Plugged air intake system.	Clean system and replace filter.
	Clogged or dirty fuel injectors.	Clean injectors.
	Fuel filters plugged.	Replace filters.
	Engine speed control cable out of adjustment.	Readjust.
	Injection pump out of adjustment.	Contact your <i>Günter Grossmann</i> dealer.
	Valve backlash faulty.	Adjust backlash.
Engine runs hot.	Low coolant level.	Add coolant.
	Thermostat faulty.	Replace thermostat.
	Radiator cap faulty.	Replace radiator cap.
	Radiator core plugged.	Clean radiator.
	Oil cooler core plugged.	Clean oil cooler.
	Fan belt loose or damaged.	Tighten or replace as required.
	Temperature sensor faulty.	Replace sensor.

HYDRAULIC SYSTEM

Problem	Cause	Remedy
None of the controls function (loud noise from pumps).	Hydraulic pump failed.	Contact your <i>Günter Grossmann</i> dealer.
	Low hydraulic oil level.	Add hydraulic oil as required.
	Suction line plugged or damaged.	Clean or replace as required.
None of the controls function (no noise from pumps).	Pilot pump failure.	Contact your <i>Günter Grossmann</i> dealer.
	Cut off solenoid valve failed.	Replace solenoid.
	Pilot cutoff switch is ON.	Adjust pilot cutoff switch clearance.

Problem	Cause	Remedy
All actuators have low power.	Low hydraulic oil level.	Add hydraulic oil as required.
	Suction filter clogged.	Clean filter.
	Hydraulic pumps faulty.	Contact your <i>Günter Grossmann</i> dealer.
	Main relief pressure too low.	Contact your <i>Günter Grossmann</i> dealer.
	Hydraulic pumps excavating.	Bleed air from hydraulic pumps.
Only one or two actions have little or no power.	Overload relief pressure too low.	Reset pressure.
	Makeup check valve leaking.	Clean or replace as required.
	Control valve spool faulty.	Replace valve spool.
	Dirt in valve spool.	Clean or replace as required.
	Actuator failed.	Repair or replace as required.
	Cylinder seal failed.	Repair or replace as required.
	Cylinder rod damaged.	Repair or replace as required.
	Remote control valve failed.	Replace control valve.
	Wrong pilot line connection.	Reconnect pilot lines.
Oil temperature too high.	Oil cooler faulty.	Contact your <i>Günter Grossmann</i> dealer.
	Fan belt loose.	Tighten fan belting as required.

SWING SYSTEM

Problem	Cause	Remedy
No swinging motion.	Swing brake valve faulty.	Replace brake valve.
	Hydraulic timer faulty.	Replace timer.
	Low brake release pressure.	Adjust pressures.
	Swing motor failed.	Replace swing motor.
	Remote control valve failed.	Replace control valve.
	Wrong pilot line connection.	Reconnect pilot lines.
Swing motion jerky.	Swing gear worn.	Replace swing gear.
	Swing bearing damaged.	Replace bearing.
	Improper lubrication.	Add grease.

TRAVEL SYSTEM

Problem	Cause	Remedy
Travel motion does not function.	Center joint leaking.	Repair or replace as required.
	Parking brake will not release.	Repair parking brake.
	Travel motor failed.	Repair or replace as required.
	Remote control valve failed.	Repair or replace as required.
	Wrong pilot line connection.	Reconnect pilot lines.
Travel speed is too low.	Track tension too high or too low.	Adjust tension.
	Damaged rollers or idlers.	Repair or replace as required.
	Track frame damaged.	Repair as required.
	Parking brake will not release.	Repair parking brake.



GÜNTER
GROSSMANN



Specification

STANDARD SPECIFICATION

COMPONENT		SPECIFICATION		
		METRIC	ENGLISH	
Bucket capacity	CECE	0.151 m ³	0.20 yd ³	
	PCSA	0.175 m ³	0.23 yd ³	
Equipment weight		5.6 metric tons	6.3 tons	
Engine	Model	4TNV98-Z		
	Type	Water cooled - 4 cylinders		
	Rated output	56.4 ps @ 2,000 rpm	55.6 hp @ 2,000 rpm	
	Maximum torque	25.3 kg•m @ 1,300 rpm	183.1 ft lb @ 1,300 rpm	
	Fuel tank capacity	115 liters	30.4 U.S. gal.	
Hydraulic pump	Type	Variable displacement axial piston pump		
	Discharging pressure	210 kg•cm ²	2,990.9 psi	
	Maximum discharge quantity	60.5 x 2 lpm+35.6 lpm	16 x 2 U.S. gpm+9.4 U.S. gpm	
	Hydraulic oil capacity	Tank Level	72 liters	19.0 U.S. gal.
System		108 liters	28.5 U.S. gal.	
Performance	Digging capability	Bucket	3.75 metric tons	4.1 tons
		Arm	2.68 metric tons	2.9 tons
	Swing speed	9.8 rpm		
	Travel speed	High-speed	4.0 km/h	2.4 MPH
		Low speed	2.4 km/h	1.5 MPH
	Traction force	High-speed	4.7 metric tons	5.3 tons
		Low speed	2.7 metric tons	3.0 tons
	Gradeability	35° (70% slope)		
	Ground pressure	0.32 kg•cm ²	4.6 psi	
Ground clearance		365 mm	14.4 in	
Track shoe width		400 mm	15.7 in	
Upper roller qty.		1 X 2 per side		
Bottom roller qty.		5 X 2 per side		

OVERALL DIMENSIONS

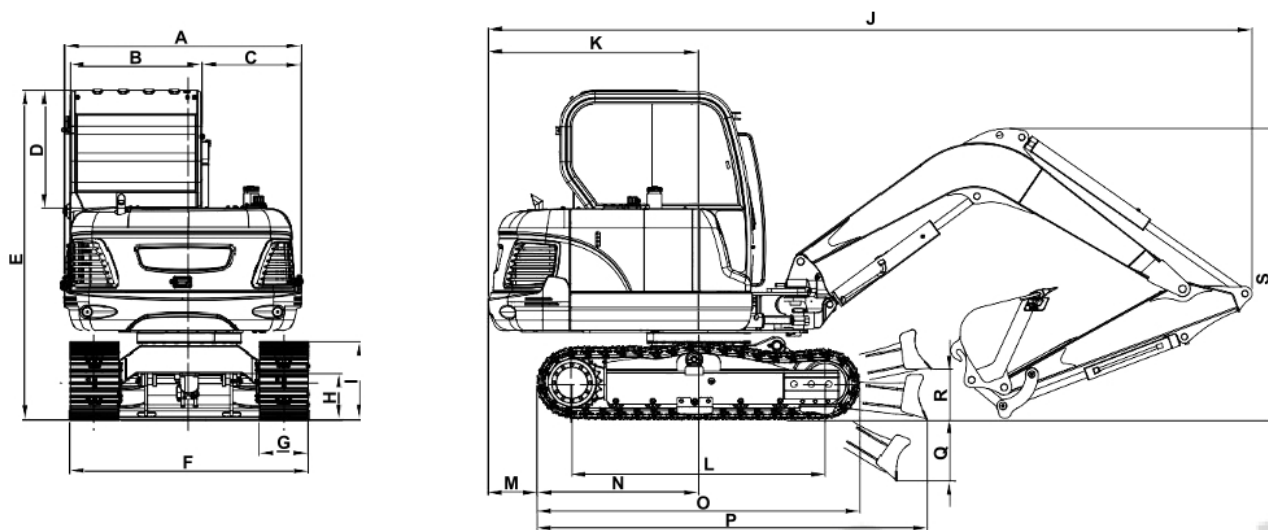

FG010285

Figure 1

DIMENSION	3 m (9' 10") ARM
A	1,850 mm (6' 1")
B	1,075 mm (3' 6")
C	775 mm (2' 6")
D	920 mm (3' 0")
E	2,500 mm (8' 2")
F	1,880 mm (6' 2")
G	400 mm (1' 4")
H	365 mm (1' 2")
I	590 mm (1' 11")
J	5,900 mm (19' 4")
K	1,650 mm (5' 4")
L	1,990 mm (6' 6")
M	400 mm (1' 4")
N	1,250 mm (4' 1")
O	2,500 mm (8' 2")
P	2,975 mm (9' 9")
Q	575 mm (1' 10")
R	350 mm (1' 2")
S	1,985 mm (6' 6")

WORKING RANGE

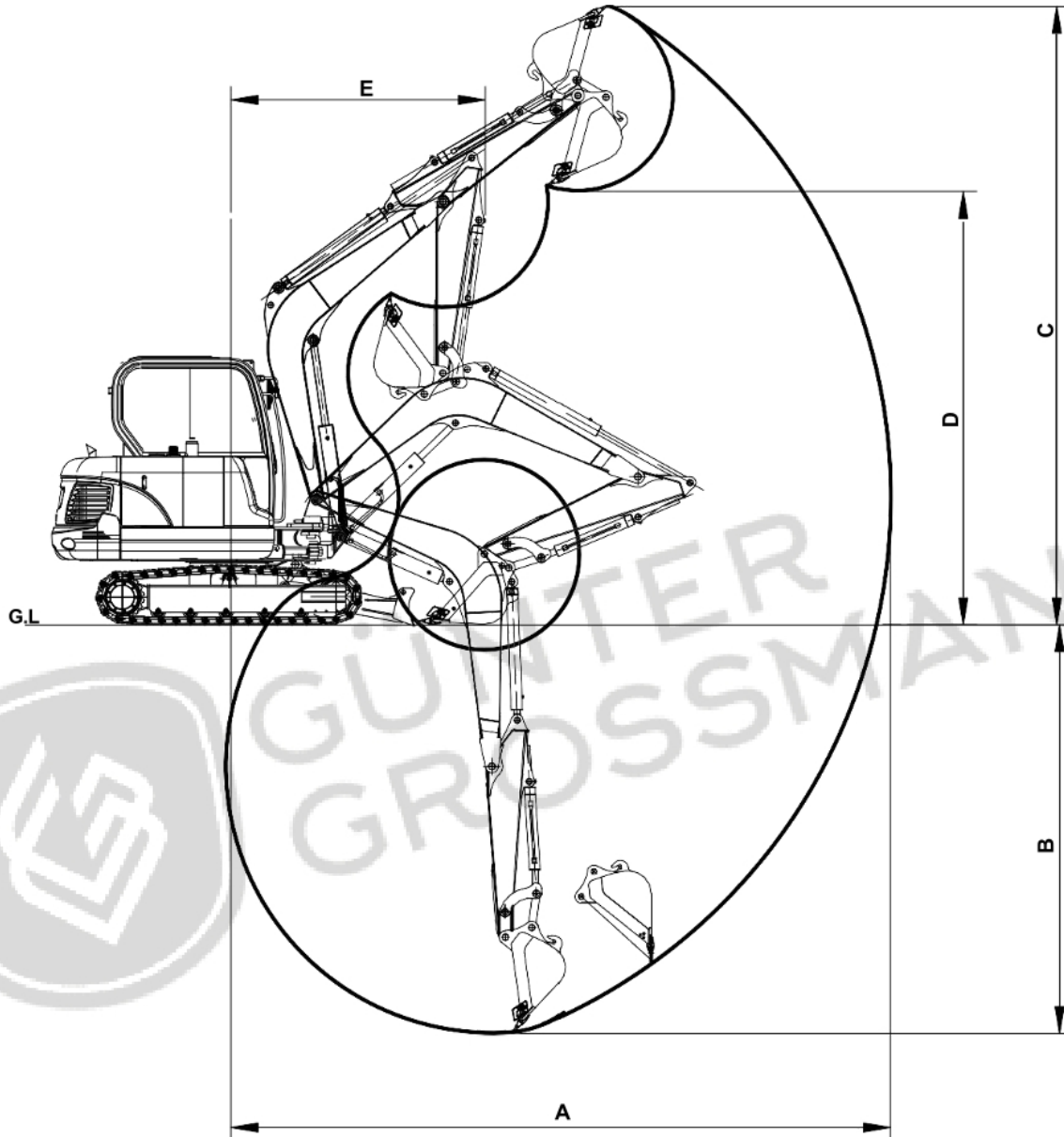

FG011313

Figure 2

DIM.		3 m (15' 1") BOOM	
		1.6 m (6' 11") ARM	
A	Max. Digging Reach	6,160 mm (20' 2")	
B	Max. Digging Depth	3,785 mm (12' 5")	
C	Max. Digging Height	5,810 mm (19' 1")	
D	Max. Loading Height	4,080 mm (13' 5")	
E	Min. Swing Radius	2,365 mm (7' 10")	

WORKLOAD MATERIALS

IMPORTANT

Weights are approximations of estimated average volume and mass. Exposure to rain, snow or groundwater; settling or compaction because of overhead weight and chemical or industrial processing or changes because of thermal or chemical transformations could all increase value of weights listed in table.

MATERIAL	LOW WEIGHT OR DENSITY 1,100 kg•m ³ (1,850 LB/YD ³), OR LESS	MEDIUM WEIGHT OR DENSITY 1,600 kg•m ³ (2,700 LB/YD ³), OR LESS	HIGH WEIGHT OR DENSITY 2,000 kg•m ³ (3,370 LB/YD ³), OR LESS
Charcoal	401 kg•m ³ (695 lb/yd ³)	-----	-----
Coke, blast furnace size	433 kg•m ³ (729 lb/yd ³)	-----	-----
Coke, foundry size	449 kg•m ³ (756 lb/yd ³)	-----	-----
Coal, bituminous slack, piled	801 kg•m ³ (1,350 lb/yd ³)	-----	-----
Coal, bituminous r. of m., piled	881 kg•m ³ (1,485 lb/yd ³)	-----	-----
Coal, anthracite	897 kg•m ³ (1,512 lb/yd ³)	-----	-----
Clay, DRY, in broken lumps	1,009 kg•m ³ (1,701 lb/yd ³)	-----	-----
Clay, DAMP, natural bed	-----	1,746 kg•m ³ (2,943 lb/yd ³)	-----
Cement, Portland, DRY granular	-----	1,506 kg•m ³ (2,583 lb/yd ³)	-----
Cement, Portland, DRY clinkers	-----	1,362 kg•m ³ (2,295 lb/yd ³)	-----
Dolomite, crushed	-----	1,522 kg•m ³ (2,565 lb/yd ³)	-----
Earth, loamy, DRY, loose	-----	1,202 kg•m ³ (2,025 lb/yd ³)	-----
Earth, DRY, packed	-----	1,522 kg•m ³ (2,565 lb/yd ³)	-----
Earth, WET, muddy	-----	-----	1,762 kg•m ³ (2,970 lb/yd ³)

MATERIAL	LOW WEIGHT OR DENSITY 1,100 kg•m ³ (1,850 LB/YD ³), OR LESS	MEDIUM WEIGHT OR DENSITY 1,600 kg•m ³ (2,700 LB/YD ³), OR LESS	HIGH WEIGHT OR DENSITY 2,000 kg•m ³ (3,370 LB/YD ³), OR LESS
Gypsum, calcined, (heated, powder)	961 kg•m ³ (1,620 lb/yd ³)	-----	-----
Gypsum, crushed to 3 inch size	-----	1,522 kg•m ³ (2,565 lb/yd ³)	-----
Gravel, DRY, packed fragments	-----	-----	1,810 kg•m ³ (3,051 lb/yd ³)
Gravel, WET, packed fragments	-----	-----	1,922 kg•m ³ (3,240 lb/yd ³)
Limestone, graded above 2	-----	1,282 kg•m ³ (2,160 lb/yd ³)	-----
Limestone, graded 1-1/2 or 2	-----	1,362 kg•m ³ (2,295 lb/yd ³)	-----
Limestone, crushed	-----	1,522 kg•m ³ (2,565 lb/yd ³)	-----
Limestone, fine	-----	-----	1,602 kg•m ³ (2,705 lb/yd ³)
Phosphate, rock	-----	1,282 kg•m ³ (2,160 lb/yd ³)	-----
Salt	929 kg•m ³ (1,566 lb/yd ³)	-----	-----
Snow, light density	529 kg•m ³ (891 lb/yd ³)	-----	-----
Sand, DRY, loose	-----	1,522 kg•m ³ (2,565 lb/yd ³)	-----
Sand, WET, packed	-----	-----	1,922 kg•m ³ (3,240 lb/yd ³)
Shale, broken	-----	1,362 kg•m ³ (2,295 lb/yd ³)	-----
Sulfur, broken	529 kg•m ³ (1,620 lb/yd ³)	-----	-----



GÜNTER
GROSSMANN

Index

Numerics

- 1,000 Hour / 6 Month Service 4-39
- 10 Hour / Daily Service 4-12
- 2,000 Hour / Yearly Service 4-45
- 250 Hour / Monthly Service 4-22
- 50 Hour / Weekly Service 4-19
- 500 Hour / 3 Month Service 4-30

A

- Adjust Valve Clearance 4-48
- Air Breather Filter 4-42
- Air Conditioner 2-23
- Air Intake System 4-17
 - Air Cleaner Clogging Warning Light 2-18
 - Outer Element of Air Cleaner 4-20
 - Replace Outer and Inner Air Cleaner Filter 4-35
- Air-conditioning Inner Filter 4-38
- Alternator and Starter 4-47
- Antifreeze Concentration Tables 4-62
- Antivibration Shock Mounts 4-47
- Auto Idle Switch 2-9

B

- Batteries 4-29
- Battery 4-57
 - Electrolyte Level 4-58
 - Safety 1-44
 - Terminals 4-58
- Blade Control Lever 3-37
- Bolt and Nut Inspection 4-49
- Boom Swing Cylinder and Bracket 4-19
- Boom Swing Pedal 3-36
- Boom, Arm and Front Attachment Pins 4-22
- Booster Cable 3-7
- Breaker Button 2-13
- Bucket 4-54
 - O-ring 4-55
 - Tooth 4-54

C

- Cabin Light 2-30
- Cabin Storage Compartments 2-38
- Charge Warning Light 2-18
- Check and Confirmation After Stopping Engine 3-13

- Cigar Lighter 2-12
- Circuit Breaker 2-30
- Cold Weather Hydraulic System Warm-up 3-10
- Cold Weather Starting 3-6
- Component Locations 2-2
- Cooling Fan Blade 4-17
- Cooling System
 - Engine 4-60
 - Radiator Coolant 4-45
 - Refill Cooling System 4-16
- Cracks and Faulty Welds 4-17
- Cycle Time Tests 4-48

D

- Description of Lubrication and Service Chart 4-8
- Door Side Latch 2-37
- Dozer Pins 4-19

E

- Electrical
 - Devices 2-30
 - Fuse Identification 2-29
 - System 4-57, 6-1
- Emergency Glass Breaking Tool 2-39
- Engine 2-19, 6-2
 - Adjust Valve Clearance 4-48
 - Check and Adjust Engine 4-44
 - Check and Confirmation After Engine Start 3-11
 - Check Warning Light 2-21
 - Coolant Temperature Gauge 2-17
 - Coolant Temperature Warning Light 2-19
 - Cooling Fan Blade 4-17
 - Cooling System 4-60
 - Fan Belt 4-27
 - Head Bolt Torques 4-48
 - Oil and Filter 4-21, 4-26, 4-34
 - Oil Level 4-12
 - Oil Pressure Warning Light 2-18
 - Shutdown 3-12
 - Speed Control Dial 2-8
 - Start 3-3
 - Start and Stop 3-2
- Excavator Rated Lift Capacity Tables 1-48

F

- Fan and Air Conditioner Button 2-24
- Fan Belt 4-21
- Fluid Capacities 4-7
- Front
 - Bottom Window 2-37
 - End Attachments 4-29
 - Upper Windows 2-36
 - Windows 2-36
- Fuel
 - Change Fuel Cap Filter 4-42
 - Filter 4-36
 - Gauge 2-17
 - Level 4-14
 - Level Warning Light 2-20
 - System 4-36
 - Tank Drain Valve 4-20
 - Transfer Pump 4-63
 - Water in Fuel Warning Light 2-21
- Fuel System
 - Transfer Pump 4-63
- Functional Check 2-17

Fuse

- Boxes 2-29, 4-59

- Fuses 4-58
- Fusible Link 2-31
- Identification 2-29, 4-59

G

Gauges

- Engine Coolant Temperature Gauge 2-17
- Fuel Gauge 2-17
- Hour Meter 2-14

H

- Handling a New Excavator 3-1
- Hanger 2-39
- Hazard Information 1-16
- Head Bolt Torques 4-48
- Heater 2-23
- Heater and Air Conditioner
 - Additional Operating Instructions 2-27
 - Blower Fan Switches 2-25
 - Control Panel 2-24
 - Inner Filter 4-40
 - Location of Vents 2-23
 - Memory Function of Used Mode 2-27
 - Refrigerant 4-44
 - Selector Switch for Wind Direction 2-26
 - Temperature Control Switch 2-25
- Heater and Air Conditioner Control Panel 2-12
- High Travel Speed Indicator Light 2-20
- Horn Button 2-13
- Hose Clamps 4-29

Hour Meter 2-14

- Hydraulic System 6-3
 - Hydraulic Breaker 3-31
 - Hydraulic Hoses and Tubing 3-31
 - Oil and Filter 3-34
 - Operation 3-31
 - Selection 3-31
 - Hydraulic Oil Exchange 4-46
 - Hydraulic Oil Return Filter 4-29, 4-37
 - Hydraulic Oil Suction Strainer 4-29, 4-40
 - Hydraulic Oil Tank 4-13
 - Leaks in the Hydraulic System 4-14
 - Main System Pump 4-33
 - Oil Exchange 4-46
 - Suction Strainer 4-46
 - Warm-up 3-9

I

Indicator Lights

- Air Cleaner Clogging Warning Light 2-18
- Charge Warning Light 2-18
- Engine Check Warning Light 2-21
- Engine Coolant Temperature Warning Light 2-19
- Engine Oil Pressure Warning Light 2-18
- Fuel Level Warning Light 2-20
- High Travel Speed Indicator Light 2-20
- Overload Warning Light 2-22
- Preheat Indicator Light 2-19
- Quick Clamp Indicator Light 2-21

Work Light 2-20

- Inspecting Engine Before Starting 3-2
- Inspection, Maintenance and Adjustment 4-1
- Instrument Panel 2-13, 2-16

L

- Leaks in the Fuel System 4-15
- Leaks in the Hydraulic System 4-14
- Levers
 - Adjusting the Seat Forward 2-32
 - Adjusting the Seat's Angle 2-32
 - Adjusting the Seat's Backrest 2-32
 - Angle Adjustment of Armrest 2-33
 - Blade Control 3-37
 - Safety Lever 2-14
- Lifting 3-38
- Lifting in Digging Mode 1-15
- Lifting With Sling 5-5
- Lights
 - Cabin 2-30
 - Switch 2-9
- Loading and Unloading 5-1
- Locations of Safety Labels 1-4
- Long Term Storage 4-65
- Lubrication and Service Chart 4-7

Index

M

Machine Control Pattern 3-22
Machine Operation 1-29
Maintenance - Safety 1-35
Maintenance in Special Conditions 4-66
Maintenance Intervals 4-10
Modifications 1-16

N

Nuts and Bolts 4-29

O

Oil Level of Travel Reducer 4-28
Opening the Window 2-36
Operating
 Controls 2-1
 Instructions 3-20
 Precautions 3-24
 Techniques 3-38
Operation 3-1
Operation In
 Dusty or Sandy Areas 3-42
 Extreme Cold 3-40
 Extreme Heat 3-41
 High Altitudes 3-43
 Rainy or Humid Conditions 3-43
 Salt Water Areas 3-43
Operation of All Switches 4-18
Operation Under Unusual Conditions 3-40
Operational Checks Before Starting Engine 3-3
Operational Controls and Panels 2-6
Operator's
 Area 2-4
 Cabin Light 2-30
 Seat Heater Switch 2-34
Outer Air Cleaner Filter 4-35
Outer Element of Air Cleaner 4-20
Overall Dimensions 7-2
Overload Warning Light 2-22
Overload Warning Switch 2-11

P

Panels
 Heater and Air Conditioner 2-23
 Heater and Air Conditioner Control Panel 2-24
 Instrument 2-13
 Instrument Panel 2-16
Parking Excavator 3-29
Pilot Cutoff Switch 2-30
Pins and Bushings 4-29
Power Mode 3-20
Preheat Indicator Light 2-19
Preliminary Work Machine Setup for Maintenance 4-3
Preventive Maintenance 4-1

Product Identification Number (PI N) Location 4-1
PTO Pedal (Optional) 3-35

Q

Quick Clamp Indicator Light 2-21
Quick Clamp Switch 2-12

R

Radiator Coolant 4-45
Refill Cooling System 4-16

S

Safety 1-1
Safety Alert Symbol 1-3
Safety Lever 2-14, 3-14
Safety Precautions 4-2
Seat Adjustment 2-32
 Adjusting Backrest 2-32
 Adjusting the Seat Forward 2-32
 Adjustment of Lumbar Support 2-33
 Angle Adjustment 2-35
 Angle Adjustment of Armrest 2-33
 Forward / Backward 2-35
 Headrest 2-33
 Seat Height Adjustment 2-32
 Suspension Adjustment 2-32
 Two-grade Forward / Backward Adjustment 2-34
Seat Belt 2-33, 4-17
Serial Numbers 4-2
Shipping and Transportation 1-47
Shutdown
 Check and Confirmation After Stopping Engine 3-13
 Engine Shutdown 3-12
 Parking Excavator 3-29
Specification 7-1
Standard Specification 7-1
Starter Switch 2-8
Starting Engine 1-25
Starting Engine Using a Booster Battery 3-7
Start-up
 Cold Weather Hydraulic System Warm-up 3-10
 Cold Weather Starting 3-6
 Engine Start 3-3
 Hydraulic System Warm-up 3-9
 Inspection Before Starting Engine 3-2
 Operational Checks Before Starting Engine 3-3
 Starting Engine Using a Booster Battery 3-7
Stereo 2-14, 2-15, 2-28
Stereo Switch 2-10
Structural Damage 4-48

Sun Visor 2-38

Swing

Bearing 4-19

Gear and Pinion 4-30

System 6-4

Swing Gear Pinion Teeth 4-19

Switches

Auto Idle 2-9

Breaker Button 2-13

Engine Speed Control 3-20

Engine Speed Control Dial 2-8

Fan Speed Selector Switches 2-25

Heater and Air Conditioner Selection Air

Outlet Selector Button 2-26

Horn Button 2-13

Light 2-9

Overload Warning 2-11

Pilot Cutoff Switch 2-30

Quick Clamp (Optional) 2-12

Starter Switch 2-8

Stereo Switch 2-10

Travel Alarm (Optional) 2-11

Travel Speed Control 3-15

Travel Speed Selector Switch 2-9

Warning Light (Optional) 2-11

Windshield Washer 2-10

Wiper 2-10

T

Table of Recommended Lubricants 4-5

Temperature Control Switch 2-25

Towing - Safety 1-46

Towing Procedure 3-30

Track Assemblies 4-21

Track Tension 4-31

Transportation 5-1

Travel 3-15

Instructions 3-16

Reduction Device 4-28, 4-29, 4-39

Speed Selector Switch 2-9

System 6-5

Travel Alarm Switch 2-11

Troubleshooting 6-1

U

Unauthorized Modifications 1-16

Unloading and Loading 5-1

V

Venting and Priming Hydraulic System

Main System Pump 4-33

Visibility Information 1-13

W

Warning Light Switch 2-11

Water in Fuel Warning Light 2-21

Water Separator 4-15

Weight of Workload Materials 7-4

Window Washer Liquid 4-16

Windows

Front 2-36

Front Bottom 2-37

Front Upper 2-36

Opening 2-36

Sun Visor 2-38

Windshield Washer Switch 2-10

Wiper Switch 2-10

Work Levers (Joysticks) (BHL Style) 3-23

Work Levers (Joysticks) (ISO Style) 3-20

Work Light Indicator Light 2-20, 2-21

Working in Water 3-28

Working Range 7-3