

Original Instruction

Operation and Maintenance Manual

Telescopic Loader

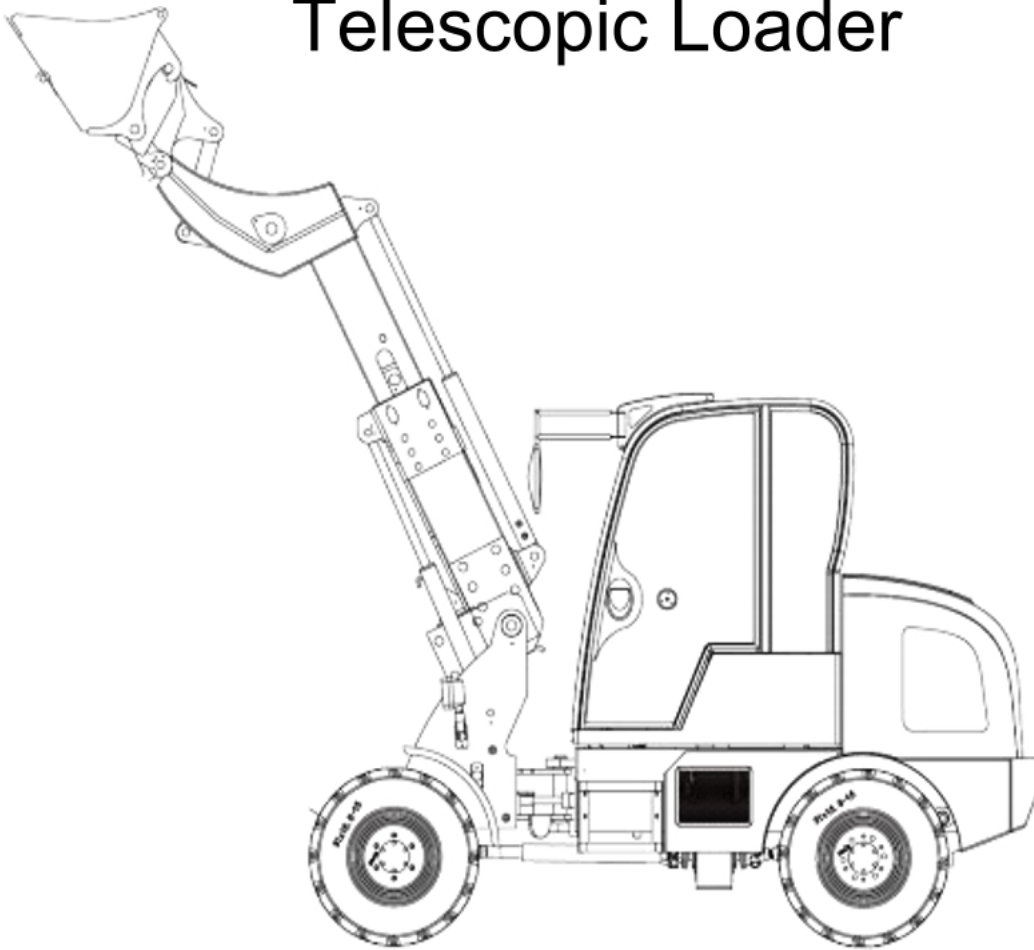

GG010T

MODEL

Warning: Improper use of this equipment may result in serious injury or death. All personnel involved in the operation and maintenance of this machine must read this manual before operating or servicing the machine. This manual should be kept near the machine for easy access, and all personnel associated with the machine should review it regularly.

Contents

1 Foreword	1
2 Notice for use	2
2.1 Scope of application	2
2.2 Signal words	2
2.3 Intended readers	3
2.4 Terms	3
2.5 Unit of measurement	3
2.6 Explanation of illustrations	4
2.7 Conformity of machine	4
3 Safety instructions	5
3.1 Basic safety rules	5
3.1.1 Know the machine	6
3.1.2 Personal protection	6
3.1.3 Burn prevention	7
3.1.4 Crushing and cutting prevention	8
3.1.5 Inhalation	9
3.1.6 Attachments	10
3.2 Intended use and reasonably foreseeable misuse	10
3.3 Operation environment	11
3.4 Residual risks and safety labels	11
3.4.1 Safety labels	11
3.4.2 Residual risks	14
3.5 Safeguards	14
3.6 Fuel requirements	17
3.7 Machine nameplate	17
3.8 Safety instructions for machine lift Cylinder	18
3.8.1 Transportation	18
3.8.2 Start	21
3.8.3 Driving	24

3.8.4 Parking	29
3.8.5 Operation	30
3.8.6 Traction	34
3.8.7 Maintenance and repair	35
4 Function and performance description	44
4.1 Machine description	44
4.2 Technical parameters	46
5 Operation	49
5.1 Safety precautions	49
5.2 Introduction of operation terminal	49
5.2.1 Operation terminal overview	49
5.2.3 Steering column B	51
5.2.4 Seat	60
5.2.5 Operation platform A	62
5.3 Typical operating procedures	65
5.3.1 Start (above 6°C)	65
5.3.2 Start (below 6°C)	67
5.3.3 Start (below -10°C)	68
5.3.4 Parking	70
5.3.5 New loader run-in	72
5.3.6 Add fuel	73
5.3.7 Add coolant	74
5.3.9 Draining fuel filter	75
5.3.10 Replace attachment	76
5.3.11 Loading operation	79
5.3.12 Pushing operation	81
5.3.13 Work on flat ground	82
6 Maintenance	84
6.1 Safety instructions	84
6.2 Preventive maintenance	84
6.2.1 Maintenance list	84
6.2.2 Oil selection table	87

6.2.3 Typical maintenance tasks	88
6.2.3.1 Joint lubrication	88
6.2.3.2 Checking the fuel tank level	90
6.2.3.3 Replacing fuel filter	91
6.2.3.4 Checking the engine oil level	92
6.2.3.5 Replacing engine oil and filter	95
6.2.3.6 Checking hydraulic oil level	99
6.2.3.7 Replacing hydraulic oil and filter element	100
6.2.3.8 Checking the transmission oil level	101
6.2.3.9 Replacing transmission oil and filter element	102
6.2.3.10 Checking the brake fluid level	104
6.2.3.11 Replacing brake fluid	104
6.2.3.12 Replacing front and rear axle gear oil	105
6.2.3.13 Replacing the air filter element	107
6.2.3.14 Replacing the coolant	107
6.2.3.15 Checking and adding cleaning fluid	109
6.3 Maintenance for long-time stop	110
6.3.1 Before long-time stop	110
6.3.2 During longtime stopping	110
6.3.3 Starting after long-time stop	111

1 Foreword

The operation and maintenance manual is an integral part of the machine for safe operation and maintenance. The manual is provided to users and shall always accompany with the machine, even in the event of resale. The manual shall be replaced immediately if lost, damaged or unreadable.

To ensure continuing safe and efficient use, any technical or functional modification of the machine which is not approved by the manufacturer is forbidden and any consequences will not be covered by support services or product warranties. Gunter Grossmann shall not be liable for any consequences caused thereby. If there is any

question with the machine, please notify Gunter Grossmann Machinery in writing, Gunter Grossmann Machinery will assess them and provide necessary information under warranty. Problems caused by improper use or non-compliance with Gunter Grossmann Machinery instructions are not covered by this warranty.

Gunter Grossmann Machinery has checked the contents of the manual to ensure that they coincide with the described machine. The information contained in the manual is reviewed regularly and any

necessary changes will be included in the next version. Gunter Grossmann Machinery is thankful for any advice for improvement.

Gunter Grossmann Machinery reserves the right to improve and upgrade the machine described in the manual, so Gunter Grossmann Machinery may adapt the technical parameters of the machine and the technical documents including the manual without prior notice.

Gunter Grossmann Machinery retains all rights of the manual. Without the written permission of Gunter Grossmann

Machinery, no part of the manual may be copied in any form. Exceptions must be granted expressly by Gunter Grossmann Machinery. Non-compliance oblige to compensation for damage and can have legal consequences.

Other documents provided and used together with the manual are shown in Table 1-1.

Table1-1 Reference document list

No.	Document name
1	Machine compliance documents
2	Electrical schematic
3	Hydraulic schematic
4	Spare parts list

2 Notice for use

Please understand the content of this chapter before reading the manual.



This chapter shows you the intended readers, symbols, terms, expression rules and product conformity in the manual.

2.2 Signal words

This safety sign identifies important safety warning messages in the manual. When you see this sign, you should be alert to possible injuries, and carefully read the message that follows and inform other users.

The signal words are shown in Table 2-1 from high to low by risk level.

Table 2-1 Explanation of signal words

Sign	Signal word and explanation
	This signal word indicates a hazard with a high level of risk which, if not avoided, will result in death or serious injury.
	This signal word indicates a hazard with a medium level of risk which, if not avoided, could result in death or serious injury.
	This signal word indicates a hazard with a low level of risk which, if not avoided, could result in minor or moderate injury.

When more than one risk level occurs, use the highest level. When a signal word contains a warning message that may cause personal injury, a warning message of possible property damage may also be attached.

2.3 Intended readers

The manual addresses the following skilled users:

Delivery personnel

Installation personnel

Operator

Maintenance personnel

 WARNING	<p>Read Chapter 3 <i>Safety instructions</i> before working for all people allowed to use the machine.</p>
--	--

2.4 Terms

The terms and explanation used in the manual are shown in Table 2-2.

Table 2-2 Term and explanation

No.	Term	Explanation
1	Bucket	A welding component used for shoveling materials
2	Lift arm	Lever arm to ensure bucket lifting and lowering
3	Rocker arm	Lever arm connected to the bucket and rotating around a fixed fulcrum
4	D u m pi ng distance	The horizontal distance between the bucket tip and the most front edge of the loader at the maximum dumping height
5	Max i m u m swing angle	The maximum rotation angle of the centerline of the front frame relative to the centerline of the whole machine in the horizontal plane
6	Max i m u m d u m pi ng height	The distance from the ground to the lowest point of the bucket lip when the bucket is lifted to the highest position and the unloading angle is the largest

2.5 Unit of measurement

The quantities in the manual are indicated in international standard units (SI Units) or derived SI Units. The units of measurement in the manual are the same as those on the machine.

2.6 Explanation of illustrations

For a better understanding of the manual, the illustrations in the manual are only for a brief description, in which the protective devices and covers may be removed.

2.7 Conformity of machine

The machine is designed and manufactured according to the standards in Table 2-3.

Table 2-3 Reference standards

No.	Standard
1	Directive 2006/42/EC
2	ISO 12100:2010 Safety of machinery - General principles for design - Risk assessment and risk reduction
3	ISO 20474-1:2017 Earth-moving machinery - Safety - Part 1: General requirements
4	ISO 20474-3:2017 Earth-moving machinery - Safety - Part 3: Requirements for loaders
5	ISO 6750:2005 Earth-moving machinery - Operator's manual - Content and format

Declaration of Conformity in accordance with Machinery Directive 2006/42/EC, is shown in *chapter 8.1 Machine compliance documents*.

3 Safety instructions

3.1 Basic safety rules

Most accidents happen because basic safety rules are not followed.

The safeguards provided by the Gunter Grossmann Machinery are only for basic accident prevention, only when safety working procedures made by the proprietor are provided simultaneously, the machine can be operated and maintained safely.

The proprietor of the machine must ensure that:

- (1)The safety regulations are posted in the respective working area;
- (2)Those persons who are concerned have been trained for their particular job and in regard to the safety regulations;
- (3)The safety regulations are adhered to.

In order to give full play to the performance of the machine without personnel injury and machine damage, users must obey the following basic safety rules:

(1)The machine must only be used for the purpose it has been designed for, refer to *chapter 3.2 Intended use and reasonably foreseeable misuse*. Do not use the machine exceeding the limits established by the technical data. Do not use the machine in a potentially flammable and/or explosive environment.

(2)Any modification that is not approved by Gunter Grossmann Machinery may be dangerous. Please consult with Gunter Grossmann Machinery before modification. Gunter Grossmann Machinery is not responsible for any injury and damage caused by unauthorized modifications.

(3)The operators should be instructed persons who got the training for operating the machine safely. Maintenance of the machine should be carried out only by skilled persons who got specialized maintenance training of the machine. The work of the electrical system should be carried out by skilled electricians in accordance with applicable electrical engineering rules. These users should be able to fully comply with safety rules and preventive measures designed to prevent personal injury or machine damage.

(4)Before using the machine, users must read the manual carefully, especially *chapter 3 Safety Instructions* and all safety labels on the machine (refer to *chapter 3.4 Residual risks and safety labels*). Users must ensure that they fully understand the meanings and strictly follow its requirements, all recommended safety protection measures and "commonsense", otherwise it will cause personal injury or machine damage.

(5)For safety, wear appropriate personal protective equipments (PPE) in accordance with local safety regulations and company's safety rules.

(6)Before any operation, focus on what you want to do. Do not operate or maintain the machine after drinking or taking medicine. These conditions are critical to your safety.

(7) Maintain good lighting conditions, a clean environment and sufficient working space to facilitate the operation and maintenance of machines.

(8) Ensure that all safety protection measures are in place and maintained in effective working states before the operation, otherwise do not operate and maintain the machine, and immediately notify the superior. Do not suspend, move, modify or remove the safeguards or control devices of the machine at any time.

(9) If the operator's vision is restricted, a signalman must be arranged. Operators should pay special attention to gestures and follow the instructions of the signalman. Ensure that all operators understand the meaning of all signals and gestures.

(10) The right side of the cab is equipped with a fire extinguisher. Ensure to know how to use it and maintain it in time according to local regulations and the instructions of the fire extinguisher.

3.1.1 Know the machine

Before operating or maintaining the machine, read this manual GG010T Operation and Maintenance Manual carefully to learn the machine structure, operation and maintenance requirements, be familiar with the location and functions of the buttons, handles, instruments, alarms and other devices of the machine.

Before and after operation, regular checks must be carried out accurately, such as whether all safety protection devices are in a safe state, the tires are worn, the tire pressure is normal, etc. It is necessary to regularly check abnormal conditions such as oil leakage, water leakage, air leakage, deformation, looseness, abnormal sound, etc..

3.1.2 Personal protection

(1) When operating and maintaining the machine, personal protective equipments should be determined according to the specific work conditions, such as hard hats, protective glasses, safety shoes, reflective vests, face shields, earplugs, protective gloves and protective clothing, etc..

(2) Do not wear loose clothes, rings, watches, bracelets, ties, scarves and other accessories. Long hair is forbidden.

(3) Compressed air may cause personal injury. When using compressed air to clean the machine, wear mask and protective clothing. The maximum pressure of compressed air used for cleaning should be less than 0.3MPa.

(4) Do not wear greasy clothes to prevent ignition.

(5) Wear non-slip shoes when cleaning the machine to prevent slipping on wet surfaces; when using high-pressure water to wash the machine, wear protective clothing.

(6) Wear protective clothing and face shield for welding operations.

(7) Wear protective glasses, protective clothing and rubber gloves when maintaining the battery.

(8) Wear protective glasses, protective clothing and personal protective gloves when replacing hot fluids such as engine oil, hydraulic oil and coolant to prevent burning.

3.1.3 Burn prevention

	<ul style="list-style-type: none">• The coolant, engine oil and hydraulic oil of the engine that just stop working are all at high temperature or under high pressure. Ensure that the engine is fully cool down before maintaining.• The cooling system contains alkali which is highly corrosive. Do not allow alkali to contact the skin or the eyes.
---	---

(1)When the engine is just stopped working, any operation to open tank cover, radiator cover or replace filter may cause severe burns. Therefore, the above operations must be performed after the engine is fully cooled down, and remove the cover slowly in order to release pressure, as shown in Figure 3-1.



(2)Do not touch the radiator. To check whether the water is cool, put your hand close to the front of the water radiator to check the air temperature.

(3)Do not to touch the engine or muffler, exhaust tail pipe, relay, etc. They must be cool enough to touch.

(4)When replacing coolant, engine oil, gearbox oil and filters, etc., use a suitable container to drain liquid, comply with local laws and regulations, and dispose waste liquid properly.



3.1.4 Crushing and cutting prevention

 WARNING	<ul style="list-style-type: none">• Do not place hands, arms or any other parts of the body between movable parts, otherwise it will easily cause the risk of crushing and cutting.• Do not inspect and maintenance when the machine is running and the engine is running.
--	---

(1) Do not place hands, arms or any other parts of the body between movable parts, as shown in Figure 3-3, such as between the working devices and the oil cylinder, between the vehicle body and the working devices, and the hinge joints of the vehicle frames. With the movement of the working devices, the space at the link mechanism will increase or decrease, and if a person approaches, it may cause a serious accident. If you need to enter between the moving parts of the machine, you must turn off the engine and place the control handle in the neutral position

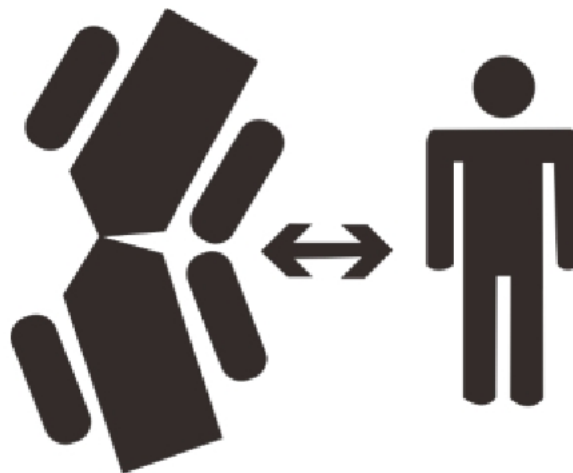

(2) When working beneath the machine, support the machine properly and reliably. Do not use hydraulic cylinders to support it. If the supporting device moves or the hydraulic line leaks, it will cause the machine to fall and cause danger.

(3) Unless otherwise specified, no adjustments, inspections and maintenance can be done while the machine is running or the engine is running.

(4) Avoid all rotating and moving parts.

(5) Ensure that the engine fan blades are free of debris. The fan blades will throw or cut the tools and debris that fall into it, as shown in Figure 3-4.



3.1.5 Inhalation

(1) Inhalation of asbestos dust is harmful to health.



(2) If there are asbestos materials in the work site, wear protective clothing and protective caps, and dust masks. Dust masks should be replaced in time, protective clothing and protective caps should be cleaned in time.

(3) Gunter Grossmann Machinery does not use asbestos in its products. When you handle any replacement parts that contain asbestos on the machine, compressed air must not be used. It should be

cleaned with water to make the dust sink.

(4)Asbestos dust in the air is dangerous. If possible, the machine should be operated at the upwind.

3.1.6 Attachments

	<ul style="list-style-type: none">• Do not use unauthorized attachments, otherwise it may cause safety problems and affect the service life of the machine.
---	---

(1)When installing and using spare attachments, read the related information in this manual.

(2)Do not use attachments that are not approved by Gunter Grossmann Machinery or Gunter Grossmann Machinery's designated dealer. Use of unlicensed attachments may cause safety issues and affect the service life.

(3)Gunter Grossmann Machinery is not responsible for damages, accidents and machine damage caused by the use of unauthorized attachments.

3.2 Intended use and reasonably foreseeable misuse

This machine is a front unloading, articulated, and tire-type compact loader. It is widely used in loading and unloading in mine, working in farm, storing grain, and production in agriculture and sideline. It is used for shoveling and short-distance transporting loose material, such as soil,sand, coal, feed, industrial and domestic waste. You can also change different attachments for snow removal,stacking, wood clamping and other operations.

This machine is used by people who are fully aware of the risks of operating the machine and have a strong sense of safety. This machine is manufactured according to the latest technology and safety standards. However, its abnormal use may cause harm to the lives and limbs of users or third parties, or cause damage to machines and other property. Therefore, any disfunction that affects machine safety should be corrected immediately.

 WARNING	<ul style="list-style-type: none"> • Users must follow the requirements in the manual. • The use of this machine for purposes other than the above-mentioned purposes will be regarded as a violation of the safety regulations of this machine. The responsibility for this risk of misuse rests solely with the operator, and Gunter Grossmann Machinery will not be liable for the damage caused thereby. • Prohibited uses include but are not limited to the following: <ul style="list-style-type: none"> • Do not use the machine beyond the limits specified in the technical parameters; • Do not load or excavate hard materials.; • Do not hang ropes on bucket lip to lift heavy objects; • Do not lift the bucket to dig above the machine.
--	--

3.3 Operation environment

 DANGER	<ul style="list-style-type: none"> • The machine is limited to be used in the following environments! Operations beyond the environments may bring greater risks or affect the machine's function and performance.
---	---

Altitude does not exceed 1500 meters.

Ambient air temperature is -15°C to +40°C.

Wading depth does not exceed 500mm.

No conductive dust and corrosive gases that damage insulation.

No vibration, shock and radiation affect the machine.

No potential flammable and/or explosive environment.

3.4 Residual risks and safety labels

3.4.1 Safety labels



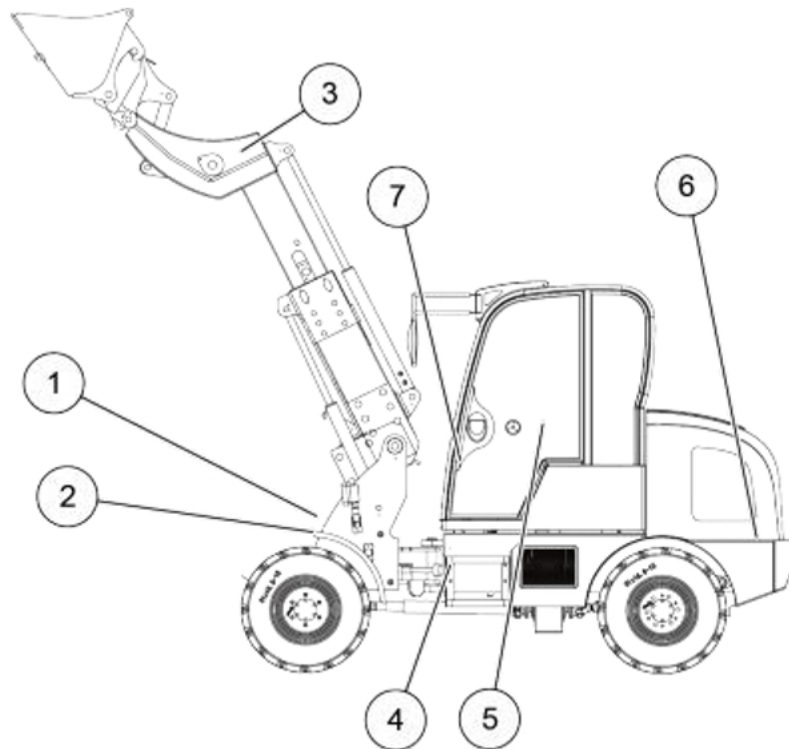

Safety labels give information of the machine's potential risks. Before operation, be familiar with all safety labels.



The descriptions of safety labels are shown in Table 3-1.

Table 3-1 Safety labels

No.	Location	Safety labels	Description
1	Front frame		Risk of injury from falling work equipment
2	Front frame		Risk of injury from lifting arm and cylinder

3	Middle of lifting arm		Risk of crushing under lifting arm
4	Front frame side		Risk of crushing during machine operation
5	Near to the door lock		Risk of crushing at the door, and close the door when the loader is running
6	Side of engine hood		Risk of crushing when the rear frame is frequently swing
7	Front panel of the cab		Notes for operators

3.4.2 Residual risks

The residual risks of the loader are shown in the table below.

	<ul style="list-style-type: none">• The coolant, engine oil, and hydraulic oil of the engine just stopping working are all in high temperature or under high pressure. At this time, any inspection, maintenance and repair activities may cause a risk of burns.• Do not put hands, arms or any other parts of the body between movable parts, otherwise it will easily cause the risk of crushing and cutting.• The fuel, lubricating oil, hydraulic oil and coolant used by the machine are all flammable liquids. Improper use and operation may cause fire or explosion risk.• Use and maintain the battery in the correct way, otherwise the battery will explode.• Inflating a tire may cause the tire to explode, which may cause fatal injuries.
---	---

3.5 Safeguards

The safeguards of the loader are shown in Figure 3-7.

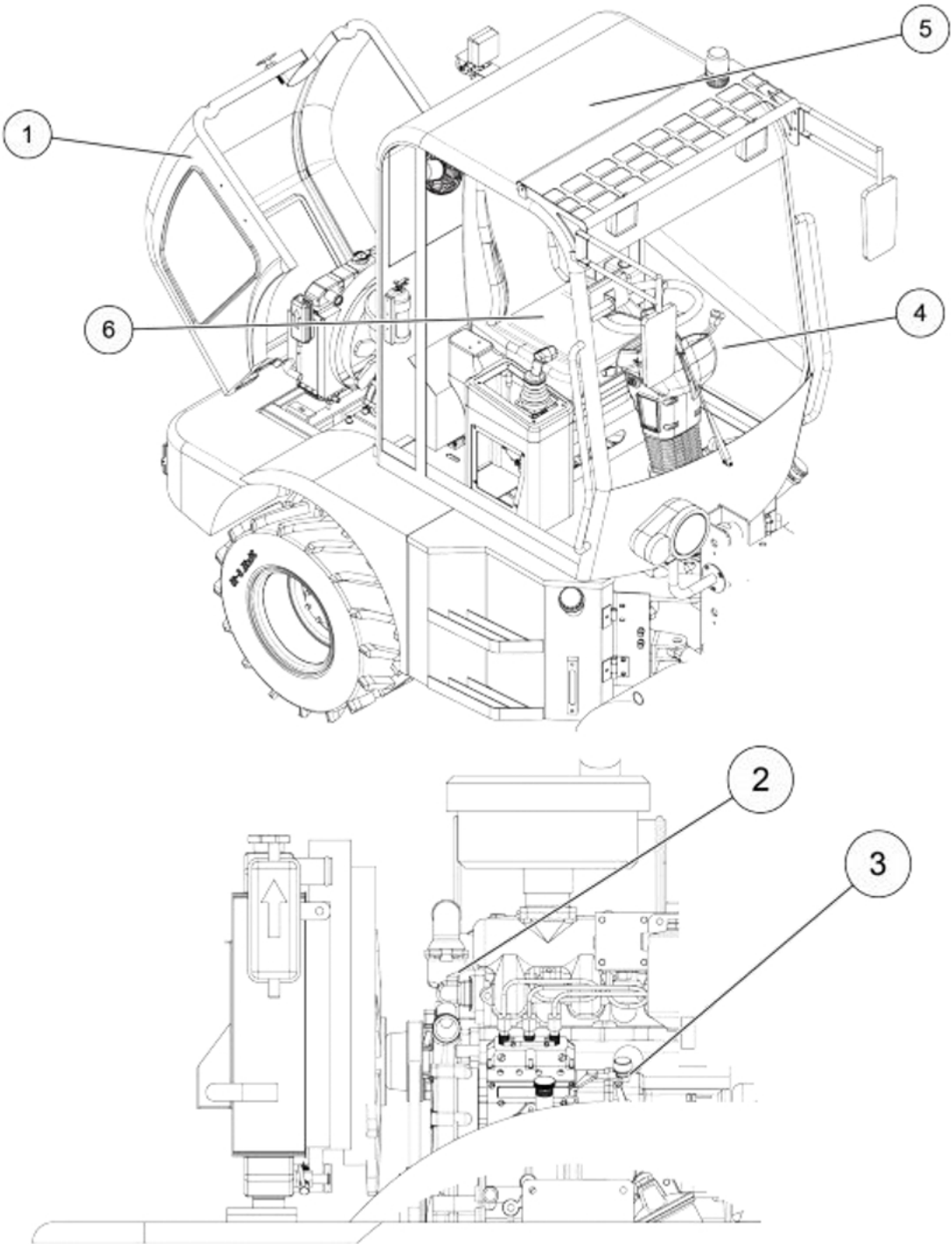



The description of the safeguards is shown in Table 3-2.

Table 3-2 Safeguards

No.	Safeguard	Description
1	Engine hood	Protect the operator from injury during operation, maintenance and repair of the loader
2	Engine water temperature alarm	Alarm when the engine water temperature is abnormal to prevent engine damage,
3	Engine oil pressure alarm	Alarm when the engine oil pressure is abnormal to prevent engine damage
4	Parking brake handle	Prevent slippery when the loader is stopped and braking in an emergency
5	Cab	Prevent heavy objects from falling when the loader is working and protect the operator in case the loader overturns
6	Seat belt	Protect the operator from injury when the machine brakes suddenly or overturns

Safety warnings related to safeguards:

	<ul style="list-style-type: none"> • Before operation, the operator must ensure that all safeguards are in place and kept in an effective working state. • Do not hang up, move, modify or dismantle safeguards or control device of the machine and its accessories at any time.
	<ul style="list-style-type: none"> • The safety protection measures taken by the machine can only reduce but not completely eliminate all dangers. • All safeguards are checked for safety functions every 250 hours. • If you need to remove and replace the safeguards for maintenance, reinstall these safeguards as soon as possible, and ensure that they are in the correct position and in an effective working state. • When the safeguards are replaced, the safety function inspection should be carried out to ensure the safety of person and machine. • Every operator must know the location and operation method of the safeguards in order to use these safeguards in emergency situations.

3.6 Fuel requirements

The fuel requirements are shown in Table 3-3.

Table 3-3 Fuel requirements

Lowest temperature	Fuel label
4°C	0# diesel oil
-5°C	-10# diesel oil
-14°C	-20# diesel oil
-29°C	-35# diesel oil

3.7 Machine nameplate

The machine nameplate is shown in Figure

3.8 Safety instructions for machine lift Cylinder

In machine lifecycle, users should obey the basic safety rules described in the manual, the safety regulations in your country/region and safety preventive measures as follow.

3.8.1 Transportation

(1)Loading/unloading

- 1)When loading or unloading loader, the engine must run at a low speed, and loader must travel at a low speed.
- 2)Before loading or unloading loader, place stops before and after the tires of transport vehicle to prevent moving. Place stops under the inclined plate to prevent the inclined plate from moving.
- 3)Use an inclined plate with sufficient strength. Ensure that the inclined plate has sufficient width and length and the angle between inclined plate and ground can not exceed 15°.
- 4)When using two inclined plates, ensure that each inclined plate is firmly placed and fixed, and the two plates shall be on same plane.
- 5)Ensure that surface of the inclined plate is clean, free of lubricants, oil stains, ice, etc., and remove dirt on loader tires.
- 6)DO NOT turn the inclined plate. If it is necessary to adjust the direction, the loader should be left from the inclined plate first, and then drive up again after adjusting direction.

7)After loading, use frame lock plate (1) to lock front and rear frames, as shown in Figure 3-9. Fix the tire of loader with stop, and tie loader rope tightly through the specified lifting lugs. The position of lifting lugs is shown in Figure 3-10.

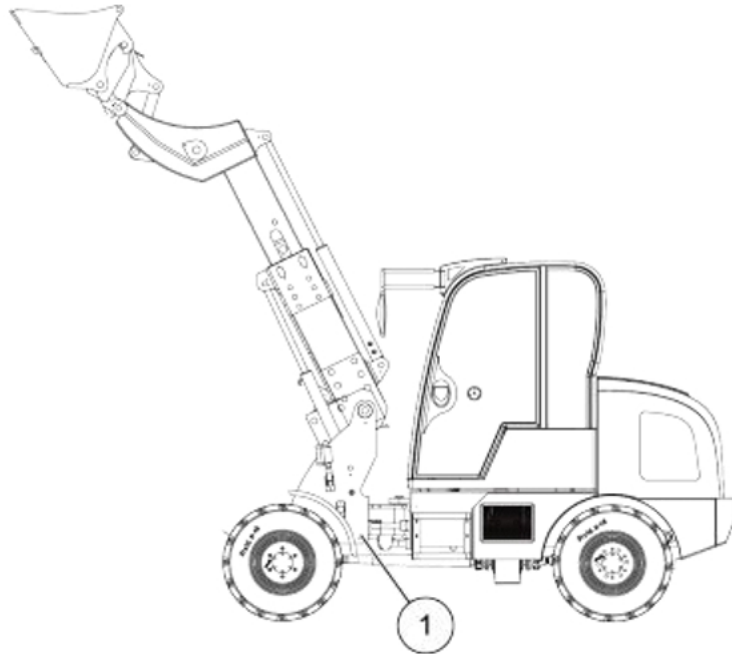

(1)Frame lock plate

(2) Lifting

 WARNING	<ul style="list-style-type: none">• During lifting process, if the rope is not fixed correctly, the loader will slip and cause serious accidents.• When using a crane to lift loader, the crane driver should be qualified.• Before lifting, be sure to lock front and rear frames with frame lock plate.• When lifting, no one is allowed in loader.
--	--

When lifting the loader, the specified lifting points on the front and rear frames should be used for lifting. The lifting points of the loader are shown in Figure 3-10.

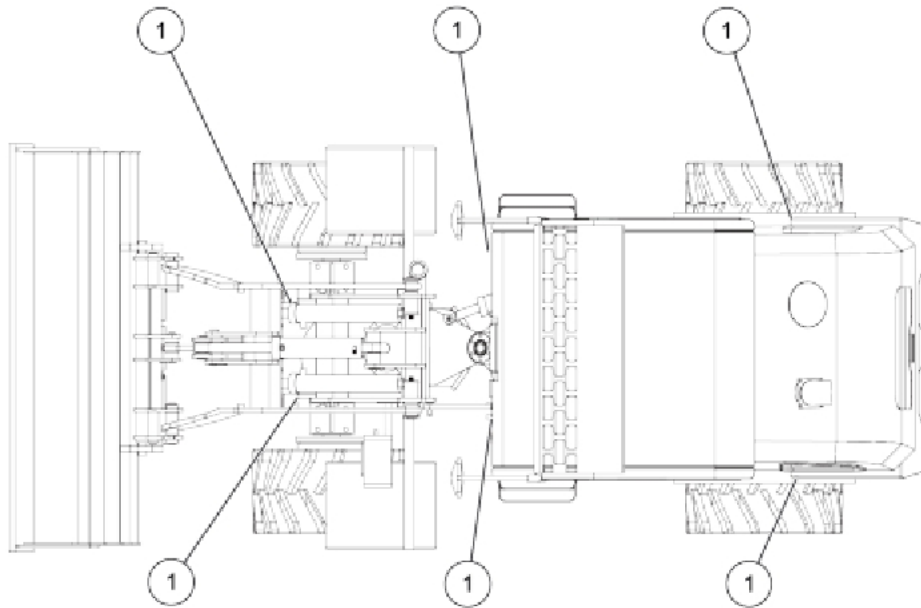

(1)Loader lifting point

Care must be taken when lifting:

- 1)All control handles should be in the neutral position.
- 2)When lifting, turn off the engine, lock all equipments with a key, and keep the key.
- 3)Do not use a piece of wire rope to connect two lifting points of front frame. Lift with six wire ropes of same length and no less than 7 meters.
- 4)Keep loader in a horizontal state after being lifted.
- 5)When lifting, do not allow any personnel or vehicle to enter under lifted loader.
- 6)After lifting is finished, the lock plates of the frame must be removed before running loader.

(3)Fixed

- 1)After loading, use frame lock plate to lock front and rear frames.
- 2)Place stops before and after tires.
- 3)Use special fixed points to fix loader to prevent loader from tipping or rolling, as shown in Figure 3-11.

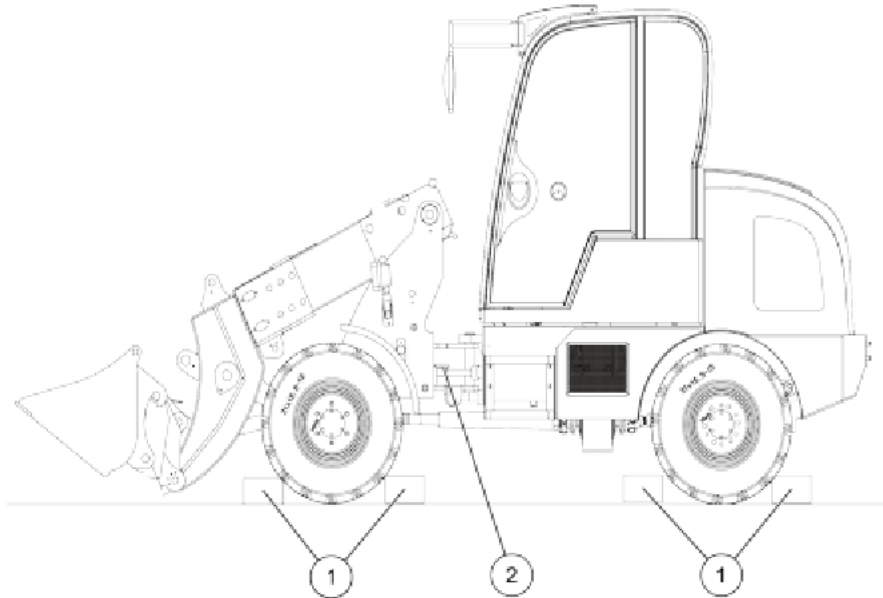

(1)Stop (2)Fixed point

(4)Road Transport

1)When transporting loader, the direction of bucket is in the same direction of transport vehicle direction.

2)When transporting loader with a trailer, comply with national and local laws on weight, height, width and length. All relevant traffic laws should also be observed.

3)The weight, height, width and length of loader should be considered when determining transportation route.

4)When passing a bridge or a structure on a private property, first check whether its strength can bear the weight of loader. When driving on public roads, comply with relevant regulations.

3.8.2 Start

(1)Before starting

1)Worksite safety

a. Before starting, carefully check whether there is any abnormal condition that may cause danger.

b. Check the topography, soil quality and ground conditions of the construction site, and determine the best and safest operation method. The ground should be roughly leveled and compacted before starting work. If there is a lot of dust on the construction site, water should be sprayed before starting work.

c. When working on highway, there should be a special person responsible for directing traffic, and set up fences and post "Do Not Enter" signs to ensure safety of personnel and vehicles.

- d. For places with buried facilities, such as water pipes, gas pipes, and high-voltage cable ducts, contact the competent authority to determine the location of the buried facilities, and pay attention not to damage these facilities during construction to ensure construction safety.
- e. When working in water or swamp areas, or passing through sandbanks, first check the ground conditions, water depth and water flow speed to ensure that the allowable water depth is not exceeded, and the bottom of the drive axle cover cannot be watered. After the work is finished, clean and check lubricating oil filling part. For depth of water see *chapter 3.3 Energy requirements*.
- f. If working indoors or other confined places, ensure effective ventilation.

2) Check before starting

- a. Before operating everyday, check machine carefully. If any abnormality is found, report it to the management immediately, and start operation after the abnormality is eliminated. Ensure that loader is in good condition, and the faults that may cause accidents shall be eliminated in advance.
- b. Carry out daily maintenance. In winter, ensure that freezing point of coolant is lower than that of cold weather, and lubricating oil is suitable for winter use.
- c. Check whether there are accumulated woodchips, leaves, paper and other flammable materials around the engine and battery, and remove them to prevent fire.
- d. Check whether the machine has oil leakage, water leakage, loose bolts, abnormal noise, damage and loss of parts, etc.
- e. Check whether there is oil, grease, snow or other dirt on cab floor, rearview mirror, control handle, pedal and armrest. Clean if necessary.
- f. Check whether coolant level, fuel oil level and oil level in engine oil pan are normal, and check whether air filter is blocked.
- g. Adjust seat to a position suitable for operation, see *chapter 5.2.4 Seat*, and check whether seat belt and fixing device of seat belt are damaged. After three years of use, seat belt must be replaced.
- h. Check whether instruments are working properly, and check parking position of control handle.
- i. Clean the window glasses of cab and all lights to ensure good visibility.
- j. Adjust rearview mirrors to proper position to ensure that operator has a good field of vision. If the glass of rearview mirror is damaged, replace it with a new one in time.
- k. Do not place or leave parts and tools around operator's seat. Due to vibrations during driving and working, these parts may fall and damage control handle or switch, or move control handle which may move working device and hence cause accident.
- l. Check whether all lighting and signal lights are normal. If there is any abnormality, repair it.
- m. Check whether front and rear frame lock plates have been removed.
- n. Clean the armrests and pedals, and remove mud on shoes to avoid slipping and affecting operation when getting on the machine.

o. Check whether tires are worn or damaged, and assembly bolts and nuts are loose. Pay special attention to check whether rim nut is loose. If any abnormality is found, repair or replace damaged part in time.

(2)Start

1)Before getting on the machine, inspect machine again and check whether there are people or obstacles on, under or near machine, or in the working area. Ensure that the area is clear of people before your working.

2)Check handrails or ladders before getting on and off. If there are oil stains, lubricants or sludge, clean immediately to prevent slipping.

3)Face the machine and maintain a three-point contact with the steps and with the handholds when getting on and off the machine. Three-point contact can be two feet and one hand, or two hands and one foot, as shown in Figure 3-12.



4)Do not start engine when there is a warning sign of "No Operation" on control handle.

5)Always sit on operator's seat and fasten the seat belt, as shown in Figure 3-13.



6)The driver's hands should be kept away from parts that may be squeezed, such as covers, doors and windows.

7)The door should be firmly closed and locked.

8)Check that work attachments have been properly connected and locked.

9) Be familiar with warning devices, instruments and control mechanisms on dashboard.

10)Ensure that parking brake handle is in braking position and all control handles are in neutral positions.

11)Honking as a warning.

12)Start engine. Refer to *chapter 5.3.1 Start (above 6°C),chapter 5.3.2 Start (below 6°C)" and chapter 5.3.3 Start (below -10°C).*

13)The engine is equipped with a preheater and DO NOT use ether to assist in starting the engine.

(3)After starting

1)After starting engine and before operating machine, ensure that there are no hazards.

2)When checking loader, it should be carried out in a spacious place without obstacles, and no one can approach machine.

3)Check whether there is abnormal noise or abnormal vibration during engine operation. If it exists, it means that the machine may be malfunctioning, and it should be reported to the manager immediately,and the operation can be started after the abnormality is eliminated.

4)In the case of neutral gear, check engine speed control.

5)Observe meters, instruments, and warning lights to ensure that they can work normally and are within specified working range.

6)Operate walking control switch to ensure that front, middle and rear gears of machine are accurate, and to ensure that control handle is flexible and free to operate.

7)Check whether brake pedal and accelerator pedal are normal, and test whether the left and right steering are flexible at low speed.

8)Before machine moves, ensure to release parking brake handle.

3.8.3 Driving

(1)Alarm

1)When loader fails to continue to work or works at low speed, turn on hazard warning light to warn the road and other road users of danger.

2)When loader reverses, the reversing alarm is automatically turned on; If the alarm is damaged, it should be repaired before operating machine.

(2) Pay attention to personnel safety

- 1) Before starting loader, honk horn to send out a signal, confirm safety before starting.
- 2) In particular, ensure that there are no people or obstacles in front, back, left or right.
- 3) Check braking effect on a dry, flat and solid road.
- 4) Do not extend your arms and hands out of loader, as shown in Figure 3-14.



- 5) Keep the door closed when driving to avoid crowding your hands.
- 6) When driving on flat ground, adjust height of the working device so that lower end of boom is 400mm to 500mm aboveground, as shown in Figure 3-15.

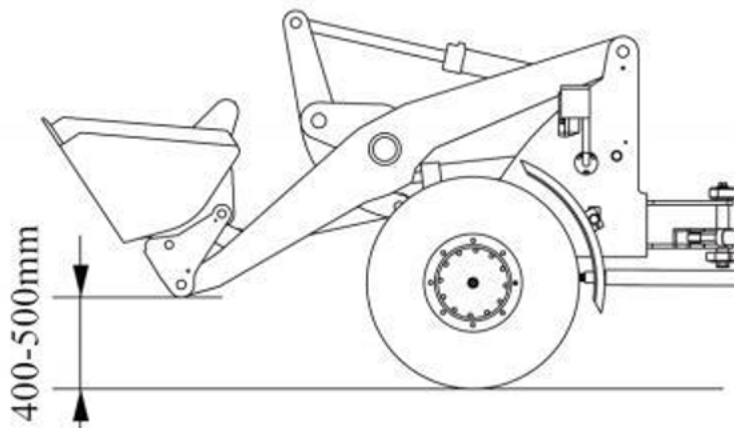

- 7) Concentrate when operating. Pay great attention to direction of travel and people working in surrounding area, and honk when necessary to warn.
- 8) When driving, cab door should be securely fixed. Do not walk when door is not locked.
- 9) Except for operator, no other people are allowed to get in cab, and no one is allowed to sit on body of machine.
- 10) Do not use a bucket as a working platform or carry people, as shown in Figure 3-16.



11)Traffic rules should be observed on ordinary roads, no road traffic obstacles should be caused, and railway crossing should be passed quickly under safe conditions.

12)Keep sideways on the road, make concessions for other cars, and keep a proper distance between cars.

13)If engine stalls while driving, brake immediately and stop machine. At this time, there is a danger of landing. Do not approach machine or enter scope of accessory, otherwise it may cause an accident, or even a fatal accident.

	<ul style="list-style-type: none">• The steering system of loader will not work after engine is turned off, and must brake immediately.• Emergency braking may cause personal injury.• Do not switch between forward and reverse gears during high-speed driving.
---	---

(3)Load transportation

1)Whether driving on road or working on site, the operator is responsible for load of loader. Do not drop load during operation, and do not load and transport obviously dangerous loads.

2)Don't lift bucket full of materials high. When transporting with a full load, the appropriate speed should be selected, and bucket should be lowered and run at an appropriate height aboveground (400mm to 500mm). This can lower center of gravity and ensure the stability of loader.

3)Do not exceed rated load of loader. Pay close attention to influence of different distances on center of gravity and different work accessories. Gunter Grossmann Machinery will not be responsible for any damage to machine or personnel caused by overloading.

4)Avoid rushing, braking, turning and walking roundabout during transportation.

5)Do not stop or drop work attachments quickly. If work accessories stop or descend rapidly, the load may be thrown away or loader may turn over.

(4)No over speed

1)To be very familiar with performance of loader, according to actual situation of job site, determine appropriate driving speed, running route and operation method of loader, and make people involved in operation know well.

2)Keep running at low speed so that loader is always in a controllable state.

3)When driving on rugged, smooth roads or hillsides, avoid high-speed driving, U-turns and sudden braking.

4)When driving in untidy places or on uneven roads, steering wheel control may sometimes be difficult. Improper control may cause accidents such as overturning, so speed must be reduced when passing.

5)The engine should run smoothly, and high-speed driving is strictly prohibited when turning.

(5)Keep good visibility

1)At places with poor vision ahead or narrow road junctions, slowdown, honking horn to warn or let people guide if necessary to avoid blind operation.

2)Weather such as sand dust, dense fog, and heavy rain will affect visibility. When visibility decreases, slowdown as much as possible. Stop working when the field of vision is not good, and wait for the weather to improve before working.

3)When loader is carrying long objects, the vision is not good, and you should be very careful when lifting, forward,backward, and shift gears, and don't let people enter working area.

4)At night, distance and height of ground are prone to illusions. Be sure to maintain lighting and drive at a suitable speed.

5)When working in a dark place, light up the front light, rear light and work light.

(6)Watch out for obstacles

1)When turning and driving in places with obstacles, be careful not to collide with the loader.

2)When driving or turning in a narrow place, pay attention to surrounding safety and reduce the speed to confirm whether there are obstacles around.

3)When road surface is in poor condition, the loading and unloading operations will be affected. Care should betaken to avoid instability of loading and unloading.

(7)Driving in harsh environments

1)Be very careful when working and driving in harsh environments and do not work alone in dangerous places. The condition of driving road surface, strength of bridge, topography of work site, and state of geology should be investigated in advance, and work should be maintained under better ground conditions.

2)When driving in damp or soft places, pay attention to wheel sinking and braking effect.

3)When working in water or swamp area, do not let bottom of drive axle get water. After wading or raining, maintain a low speed when starting loader, and lightly step on brake pedal to dry brakes.

4)Avoid driving loader close to suspended objects or deep ravines. The weight or vibration of machine may collapse these areas, causing machine to tip over and cause death.

5)When it is raining, work with caution. When there are accumulations on site after earthquakes and blasting, work with extreme caution.

6)When driving on snowy roads, install tire snow chains and drive at low speed to avoid sudden starting, stopping or turning; Never apply brakes suddenly, brake intermittently, and lower bucket to ground if necessary to stop machine.

7)When working on snowy ground, the adhesion of ground will change greatly due to influence of snow, reduce load to avoid slipping when machine is driving.

8)When performing snow shoveling tasks, you must be especially careful because you cannot see road shoulders or other things buried under snow.

(8)Driving on ramp

1)When driving on steep hills, dams or slopes, improper operation may cause overturn or slip, so be careful.

2)When driving longitudinally on hillsides, dams or slopes, keep bucket close to ground by about 200mm to 300mm. In an emergency, bucket should be quickly lowered to ground to help stop

loader or prevent it from tipping over.

3)Do not turn on ramp, and do not drive laterally or change direction on ramp, otherwise loader may fall over. Drive to a flat place before turning operations, as shown in Figure 3-17.

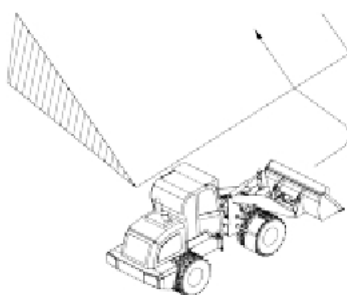

Right

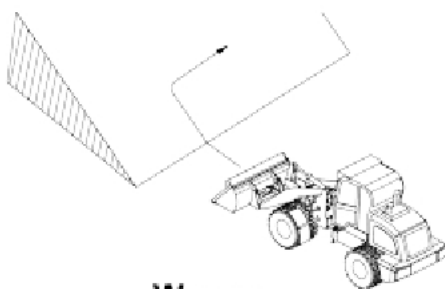

Wrong

4) Do not drive on grass, fallen leaves or wet steel plates. These places may cause loader to slip. If driving along edge of a slope, keep a very low speed.

5) Choose a suitable gear before going downhill, never shift gears during downhill process, and prohibit neutral gear.

6) When driving with full load on a ramp, use a low gear. The uphill adopts forward way, and downhill adopts backward way, without turning.

7) Drive slowly when going downhill, and prohibit the engine from stalling.

8) When engine stalls on a slope (slope should be less than 15°), immediately step on brake, lower bucket, and pull up parking brake handle. Put control handle in neutral position and restart the engine.

3.8.4 Parking

 WARNING	<ul style="list-style-type: none">• Do not get on and off loader while loader is driving.• When leaving seat, make sure that parking brake handle is in a reliable braking position, otherwise it may cause a serious accident.
--	--

(1) Park loader on ground as flat as possible, lower and level work accessory.

(2) Avoid parking on a slope. If need to park, put stop under wheel and lower bucket to ground to prevent loader from moving, as shown in Figure 3-18.

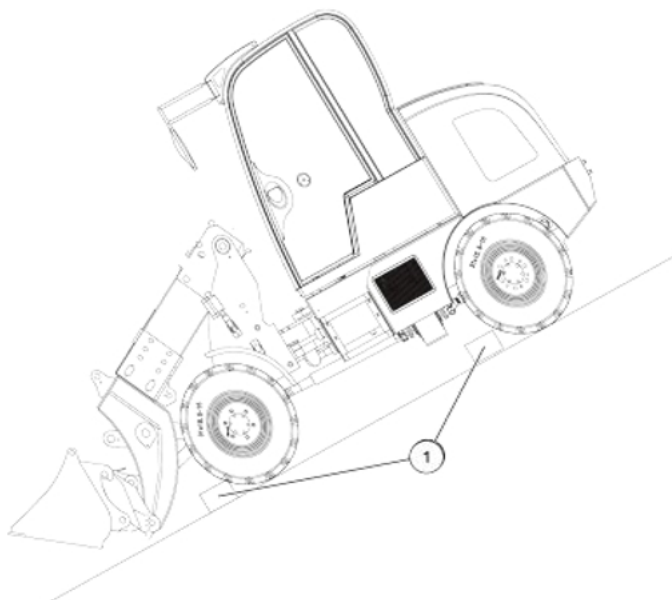

(1) Stop

(3) Release residual pressure after parking.

(4) When parking on highway, pay attention to placing safety guardrails, signs, flags or signal lights, so that passing vehicles can clearly notice parked loader. When parking, pay attention to avoid obstructing traffic such as loaders, safety fences, and flags.

(5) Park after leaving loader, refer to "5.3.4 Parking".

3.8.5 Operation

(1) Keep good operating habits

- 1) Adjust seat, adjust steering wheel and rearview mirror.
- 2) Always sit on seat and fasten seat belt during operation, as shown in Figure 3-19.



- 3) Scrape/wipe glass windows before operation to ensure a clear view.
- 4) Operate control handle accurately to avoid misoperation.
- 5) If there is a fault, report for repair immediately. Do not repair parts in working condition.
- 6) Vibration or shaking during operation may be harmful to operator. The vibration can be reduced by following steps:
 - a. Adjust seat and fasten seat belt.
 - b. Choose a relatively flat operating surface for loader (level ground if necessary).
 - c. Adjust speed of loader.
- 7) Weight of load should be confirmed in advance to avoid overload.
- 8) Gunter Grossmann will not be responsible for any damage to machines or personnel caused by overloading.

9) High-speed rushing is an extremely dangerous and wrong operation method, which will not only damage loader and operator, but also damage goods.

10) Do not open door during driving and operation.

11) The loader must keep a vertical angle for loading and unloading. If you reluctantly work from an oblique direction, it will aggravate damage to steering cylinder and differential, and cause loader to become unbalanced and unsafe.

12) Before carrying out operations in narrow areas such as tunnels, flyovers, garages, etc., check site cleanup. Be careful not to cause collision accidents during operation.

13) Loading materials in windy weather should be operated downwind.

14) When lift arm is raised to highest, the movement of loader and forward tilt of bucket should be carried out slowly.

15) When loading a truck or dumper, care should be taken to prevent bucket from hitting truck or dumper. No one can stand under the bucket and the bucket cannot be placed above truck cab.

16) Operation should be stopped when visibility is reduced due to smoke, fog, dust, etc. If there is insufficient light at job site, lighting equipment must be installed. When working at night, please pay attention to the following points:

a. Appropriate lighting equipment must be installed;

b. Ensure that working lights on loader are normal;

c. It is unfavorable to grasp height and distance of objects during night work. Reduce speed and work carefully;

d. Be vigilant when working at night, shutdown frequently to observe surrounding conditions and check loader.

17) Before crossing a bridge or other building, make sure it has enough strength to allow loader to pass.

18) Do not use loader for purposes other than professional operations. Using head or part of working device for hoisting, grasping, dialing, pushing, or traction by operating mechanism may damage machine or cause an accident.

(2)Operation in hazardous areas

1)The loader operator must be responsible for work area of loader.

2)No idlers are allowed to enter working area. Since working device is ascending and descending, rotating left and right and moving back and forth, the surroundings (bottom,front, back, inside, and both sides) of working device are dangerous and are not allowed to enter.

3)Do not allow people enter or stay in danger zone (that is, within at least 7 meters in all directions from working loader). When a person is allowed to stay in danger zone, pay attention to observation, and only operate loader when he or she is clearly told where he or she is.

4) Do not stand or walk under raised lift arm unless safety measures have been taken or lift arm has been supported.

5) When working on roadsides or places where cliffs may collapse, safety methods must be implemented, and monitors must be assigned and follow their instructions.

6) When unloading sand or rocks from a high place, pay full attention to safety of drop site. When load is unloaded, load will suddenly decrease and speed of loader will suddenly increase, so you must slowdown in advance, especially when loader reaches edge of a cliff or top of a slope.

7) Do not work too close to edge of embankment and ramp. When unloading soil on edge of embankment and ramp, first unload one pile, and then use second pile to push first pile.

(3) Operation in areas with pipelines, power lines or cables

1) Employers are responsible for knowing location of gas pipes, water pipes, sewage pipes or transmission lines and cables on construction site, marking them, and then notifying operators about their conditions. If this work is not carried out, it will bear legal responsibility.

2) Transmission lines and cables must be properly protected to avoid damage, and information about where gas and water can be shutdown should be obtained. Once the pipeline ruptures, they can be shutdown quickly.

3) When exhaust gas of muffler is sprayed to flammable materials, or exhaust pipe is close to flammable materials, fire and explosion are likely to occur. Therefore, you must pay special attention when working in places where there are dangerous substances such as fats, raw cotton, paper, hay, chemicals, or other flammable substances.



(4) Operation in areas close to high-voltage cables

When working close to high-voltage overhead transmission lines, observe very carefully, because electric arcing may damage loader and injure operator at a distance from transmission line. Please note the following:

1) Keep safety distance shown in Table 3-4 between machine and cable.

Table 3-4 Various voltage safety distance tables

Type	Voltage	Minimum safety distance
Low voltage	100V-200V	2m
	6,600V	2m
High voltage	22,000V	3m
	66,000V	4m
	154,000V	5m
	187,000V	6m
	275,000V	7m
	500,000V	11m

2)When there is a danger that machine may touch cable on construction site, should check with power company for voltage of cable before start of operation, and inquire whether action determined in accordance with current relevant regulations is feasible.

3)Do not let machine approach or touch overhead high-voltage cables.

4)Put on rubber boots and rubber gloves. Put a rubber pad on operator's seat and be careful not to let any exposed part of body touch metal chassis.

5)Designate a signaller to send a warning signal if machine is too close to cable.

6)Once working device touches cable, operator should not leave cab, stay still on seat, and do not touch machine until other people on ground safely cut off power.

7)When working near high-voltage cables, do not let anyone approach machine.

(5)Operation in an enclosed space

1)If must operate or handle fuel, clean parts or paint in a enclosed or poorly ventilated place, you need to open doors and windows to ensure adequate ventilation and prevent harm to human body. If opening doors and windows still cannot provide sufficient ventilation, ventilation equipment such as fans should be installed.

2)When working in a enclosed space, a fire extinguisher should be equipped first, remember its storage location and master method of use.

(6)Operation in cold weather

1)Use low-viscosity fuel, hydraulic oil and lubricating oil and add appropriate antifreeze. Please refer to *chapter 6.2.2 Oil selection table* for specific oil products.

2)Precautions for using coolant:

- a. Do not use coolants containing formaldehyde, ethanol, and propanol.
- b. Never use any anti-leakage agent, regardless of whether it is used alone or together with coolant.
- c. Do not mix different brands of coolant.

 WARNING	<ul style="list-style-type: none">• Keep away from open flames when adding coolant.• Coolant is an alkaline substance and is highly corrosive. Avoid contact with skin and eyes.
--	---

3)When surrounding temperature drops, the battery capacity also drops. Before shutting down, keep charging rate close to 100% as much as possible, and try to keep it warm or move it to a warm place, and reinstall it when operation next day.

4)When battery is frozen, do not charge or start engine. Remove battery, put it in warm room or warm water (be careful not to let water enter the battery), and slowly heat to 15°C, otherwise it may explode.

5)After a day of work and shutdown, thoroughly remove silt and water from machine to avoid damage to seal due to silt, water or snow entering seal and freezing.

6)Park loader on a dry hard surface, if it is impossible, park loader on wooden board. The use of wooden boards can prevent loader from being frozen on ground and facilitate loader to start next day.

7)When weather becomes warmer, corresponding parts should be replaced with engine oil, fuel oil and hydraulic oil suitable for ambient temperature.

3.8.6 Traction

 WARNING	<ul style="list-style-type: none">• Incorrect traction method or wrong wire rope selection may result in injury or death.• When traction, you must be very careful to avoid serious or even fatal injuries.
--	--

(1)If loader engine cannot be started, brake and steering of loader cannot be operated, and parking brake may not be opened,traction is not allowed at this time. Please be sure to lift loader into a pallet truck before transporting.

(2)If loader engine can be started and brakes and steering can be operated, traction is allowed at this time.

(3)The traction rope must be able to withstand weight of loader, and must not have cut strands, kinks and diameter reduction.

(4)Reduce angle of traction rope as much as possible to ensure that angle between traction rope and centerline of two vehicles is within 30°, and height of traction point of two vehicles should be close.

(5)The weight of traction vehicle must be heavier than loader, and it must have sufficient traction and braking capabilities to pull and brake two vehicles when going up or downhill.

(6)If through mud or uphill, use two traction ropes or tow bars that can withstand at least 1.5 times weight of machine.

(7)Traction on a slope is dangerous. Choose a place where slope is as gentle as possible.

(8)When traction downhill, use a vehicle with sufficient traction and braking power, and then use another vehicle behind loader. This can ensure that loader will not lose control and overturn.

(9)When traction, start and stop slowly, drive slowly, and turn on hazard warning light.

(10)When traction, no one is allowed to walk between machines.

(11)When traction, the speed shall not exceed 10km/h, and as far as possible to nearest repair place. If traction distance exceeds 10km, loader needs to be transported on a trailer.

(12)If engine of loader cannot be started or brake system is faulty, contact designated dealer of Gunter Grossmann Machinery.

3.8.7 Maintenance and repair

(1)Precautions for maintenance and repair

 WARNING	<ul style="list-style-type: none">• The hydraulic system is always under internal pressure, so when inspecting or replacing the piping or hoses, always release the pressure in the circuit before starting.• When opening the water tank cap, make sure that the engine is sufficiently cooled to prevent scalding caused by the spray of coolant.
--	--

a.Only authorized personnel can service and repair the machine. Do not allow unauthorized personnel enter the area.

b.When repairing the machine, please designate a person in charge, formulate an operating procedure and proceed step by step. Seek help from Gunter Grossmann Machinery when needed.

c. Do not wear loose clothing and accessories. Always wear a hard hat and safety shoes. If the nature of the work requires it, wear safety glasses, mask, gloves, ear plugs, and safety belt when operating or maintaining the machine.

d. Use only tools suited to the task and be sure to use the tools correctly. Using damaged, low quality, faulty, makeshift tools or improper use of the tools could cause serious personal injury.

e. In order to prevent personal injury, lower the work equipment completely to the ground and stop the engine, set parking lever to the LOCK position. If necessary, put blocks under the track to prevent the machine from moving.

f. Please be sure that you fully understand this manual and the precautions described in this manual and the safety labels on the machine. When operating or servicing the machine, always follow these precautions strictly. If the labels are damaged, lost, or cannot be read properly, replace them with new ones.

g. Attach a "Do Not Operate" warning tag or a similar warning tag to the start switch or to the controls before you service the equipment or before you repair the equipment. Attach additional warning tags around the machine if necessary.

h. Always keep the workplace clean and tidy to enable you to carry out operations safely. Wipe up all grease, oil, or other substances that will cause you to slip. If the workplace is not kept clean and tidy, there is the danger that you will trip, slip, or fall over and injure yourself.

i. Never smoke or use any flame near fuel, oil or the battery.

j. Place attachments that have been removed from the machine in a stable condition so that they do not fall. And take steps to prevent unauthorized persons from entering the storage area.

k. Check equipment used for lifting or supporting components, such as pulley belts, slings, ratchet pulleys, and ground supports, to ensure that they comply with current national regulations.

l. When doing maintenance work with lift arm lifted, keep control handles in neutral position, pull up parking brake, and use necessary support devices to prevent accessory from falling.

m. Before lifting frame with a jack, use frame lock plate to lock front and rear frames, keep control handles in neutral position, and place stoppers on front and back of tire. After lifting, put a supporting block under frame.

n. After engine is turned off, there may be residual pressure in pressure vessel, hoses, pipelines and quick couplings. Release pressure to prevent danger during maintenance.

o. When doing maintenance of electrical system or doing welding operations on machine, disconnect negative electrode of battery and disconnect wire connector on transmission computer control panel, restore connection after maintenance.

p. Do not remove radiator cover before water tank is cooled. When opening radiator cover, slowly unscrew radiator cover to deflate and then remove cover.

(2) maintenance and repair of hydraulic system

	<ul style="list-style-type: none"> • When inspecting or replacing the piping or hoses, always • Replace the hose if any of the following problems are found: <ul style="list-style-type: none"> • Damaged or leaking hydraulic fitting; • Frayed or cut covering or exposed reinforcement wire layer; • Covering swollen in places; • Twisted or crushed movable portion; • Foreign material embedded in covering.
---	--

1)When inspecting or replacing the piping or hoses, always release the pressure in the circuit and wait for the temperature to go down before starting.

Procedure for releasing internal pressure of hydraulic system:

- a.Lower the work equipment completely to the ground and stop the engine.
- b.Turn the starting switch to the ON position.
- c.Operate control lever back and forth 3-4 times, and hold the control lever at its end for 3 seconds. After the pressure is released, the hose will become "slack".
- d.However, the pressure cannot be completely released, so loosen the screws slowly, and never stand in the direction oil spurts out. At the same time, pay attention to collecting excess hydraulic oil.

2)Do not bend or hammer high-pressure pipelines. Do not install abnormally bent or damaged hard pipes or hoses on the machine.

3)Check that all the hose and tube clamps, guards, and cushions are securely fixed in position. If they are loose, they may vibrate during operation and rub against other parts. This may lead to damage to the hoses, and cause high-pressure oil to spurt out, leading to fire damage or serious injury.

4)Do not repair and reuse the crimping hose (or hose) after it is damaged, replace it with new components as a whole.

5)There is a hazard that high-pressure oil leaking from small holes may penetrate your skin or cause blindness if it contacts your eyes directly. When carry out inspection, wear safety glasses and leather gloves. If necessary, use thick cardboard or small wooden blocks to stop the leak, as shown in Figure 3-21.

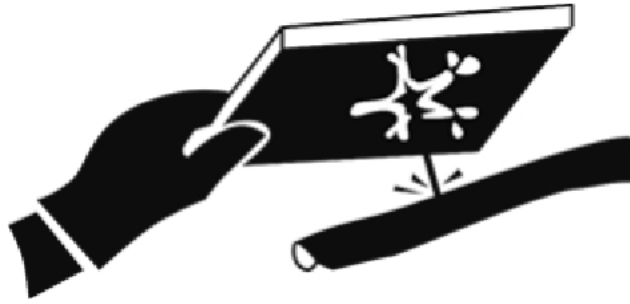

(3)Maintenance and repair of electrical system

Before servicing the electrical system, be sure to stop the machine and remove the start switch key.

1)Battery maintenance

Battery electrolyte contains sulphuric acid, and batteries generate flammable hydrogen gas, which may explode. Mistaken handling can lead to serious injury or fire. For this reason, always observe the following precautions.

- a. When working with batteries, always wear safety glasses and rubber gloves. If sulphuric acid gets on your clothes or on your skin, immediately wash it off with a large amount of water. If sulphuric acid gets in your eyes, wash it out with fresh water and consult a doctor.
- b. If you accidentally drink the electrolyte, drink plenty of water or milk, raw eggs or vegetable oil, and call a doctor or emergency center for help immediately.
- c. Do not bring open flames near the battery, or do anything that will cause sparks. If a tool touches the positive terminal and the chassis, there is danger that it will cause a spark, so be extremely careful.



d. Clean top surface of battery with a cloth, never use gasoline, organic solvents or detergents. The battery is flammable and should be kept away from open flames.

e. Do not put down battery, do not apply any mechanical shock or heavy pressure to battery.

f. When machine is not used for a long time, remove battery and store it in a dry, clean and well-ventilated environment at 5 to 25°C, while avoiding direct sunlight and at least 2 meters away from heat source. Charge battery every 3 to 6 months to keep battery performance.

g. Before installing battery, read safety signs on battery. Do not knock end post and apply a small amount of petroleum jelly to end post to prevent corrosion.

h. When removing the battery, first disconnect the negative (-) terminal. When installing, install the positive (+) terminal first. Do not use or charge the battery if the battery electrolyte level is below the LOWER LEVEL line. Always check the battery electrolyte level periodically and add distilled water to bring the electrolyte level to the UPPER LEVEL line.

i. When installing battery, tighten all screws to prevent battery damage caused by loosening.

j. The battery is equipped with an indicator showing charge state. Use it normally when indicator is green, charge in time when indicator is black, and replace it immediately when indicator is white.

k. When battery loses power, charge in time to prevent performance reduction caused by battery sulfation.

2) Charging the battery

If any mistake is made in the method of charging the battery, it may cause the battery to explode, so always do as follows.

a. When the battery is normally charged, charge the battery at a constant voltage of 24V DC for no more than 24 hours (maximum current does not exceed 25A).

b. Make sure that it is dismantled before charging. Choose a well-ventilated place for charging, and remove the top cover of the battery, so that hydrogen can diffuse and prevent explosion.

c. Connect the positive (+) charger clip of the charger to the positive (+) terminal of the battery, then connect the negative (-) charger clip of the charger to the negative (-) terminal of the battery. Do not charge in reverse, as shown in Figure 3-23.

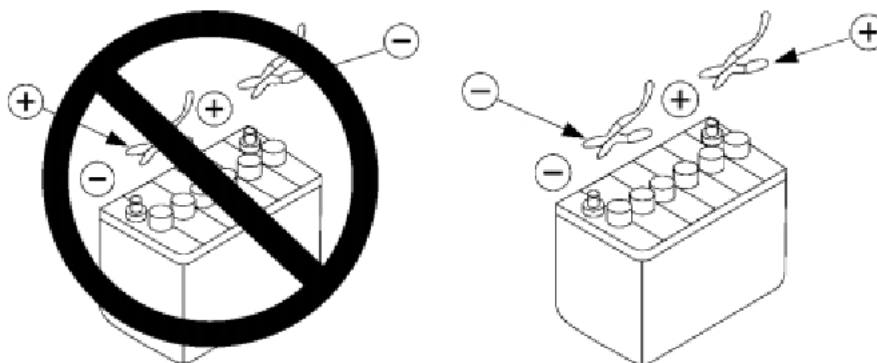

d. Regularly check whether vent on battery is blocked to prevent gas generated during charging from causing an explosion.

e. When battery electrolyte temperature exceeds 45°C during charging process, reduce charging voltage or charging current to prevent electrolyte from splashing.

f. Do not overcharge.

g. If the battery electrolyte is frozen, do not charge the battery or start the engine with a different power source. There is a hazard that this will ignite the battery electrolyte and cause the battery to explode.

(4)Maintenance and repair of tire

 WARNING	<ul style="list-style-type: none">• Inflating and welding the rim may cause explosions. When doing these operations, make sure this area is clear.
--	--

1)Inflating may cause tire explosion. A tire explosion may cause fatal injuries, as shown in Figure 3-24.

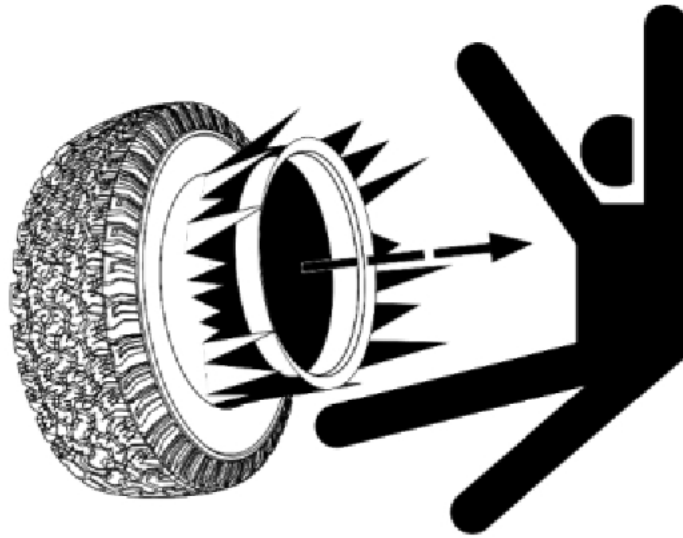

2)When inflating, use a hose long enough to keep away from the tire. During inflating, make sure that there is no one in this area, as shown in Figure 3-25.

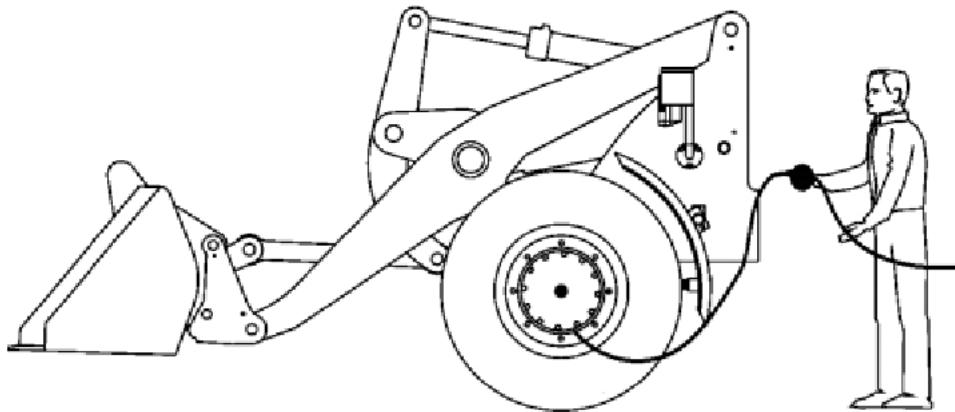

3)The air pressure should refer to *chapter 4.2 Technical Parameters*.

4)Before the first use, adjust the tire pressure in time.

5)Repairing or welding rims for pneumatic tires may cause cracking or explosion, which may cause fatal injuries.

6)Repair work on tires and rims must be performed by professionals.

7) If replacing tires, check the tightening of the wheel bolts after 10 hours.

(5) Maintenance and repair of gas tank

	<ul style="list-style-type: none">• Before starting the machine, make sure that the drain valve is closed, otherwise the brakes will fail and cause accident.
---	---

1) Drain the gas tank every day, especially in winter. For the drainage method, please refer to *chapter 5.3.5 Drainage of Gas Tank*.

2) The accumulator is charged with high-pressure gas. For this reason, regularly inspect the anti-corrosion layer and welds to ensure its safe use.

3) Before starting the machine, make sure that the drain valve is closed, otherwise the brake system will fail and cause accident.

(6) Repair welding

	<ul style="list-style-type: none">• When carrying out welding, remove the negative terminal of the battery and disconnect the cable on the computer control panel to prevent the flow of current.
---	---

Welding operations must always be carried out by a qualified welder and in a place equipped with proper equipment. The following precautions must be observed when welding:

1) Wear protective clothing and use approved respirators for welding operations.

2) Ensure good ventilation at the welding site.

3) Move any flammable materials to a safe place before starting, and equip fire extinguishers at the work site.

4) When carrying out welding, remove the negative (-) terminal of the battery and disconnect the cable on the computer control panel to prevent the flow of current. After repairing, be sure to

connect the wiring as required.

5) Remove the paint from the place where welding is needed to prevent the generation of harmful gases.

6) Cover rubber hoses, wires or pressured pipes with fire baffles when welding. Flying sparks may cause these pipes to burst suddenly, and the insulation of the wires may be damaged.

7) Do not carry out welding near the tire, otherwise the tire may explode due to heat.

(7) Machine cleaning

	<ul style="list-style-type: none">• The accumulated dust and debris on the machine should be cleaned every day to eliminate the risk of fire.• Do not use strong detergents or chemicals to avoid damage to the paint.
---	---

1) Park the machine in a place dedicated to cleaning

2) The temperature of cleaning water should not be higher than 60°C.

3) If a high-pressure cleaner is used, a distance between the nozzle and the machine must be at least 20 to 30 cm. Excessive pressure or close distance can cause damage.

4) Use appropriate methods to protect electrical wires.

5) If the label falls off, is broken or is illegible, it must be replaced immediately, see *chapter 3.5 Warning Signs and Residual Risks*

4 Function and performance description

4.1 Machine description

The main components of the loader are shown in Figure 4-1.

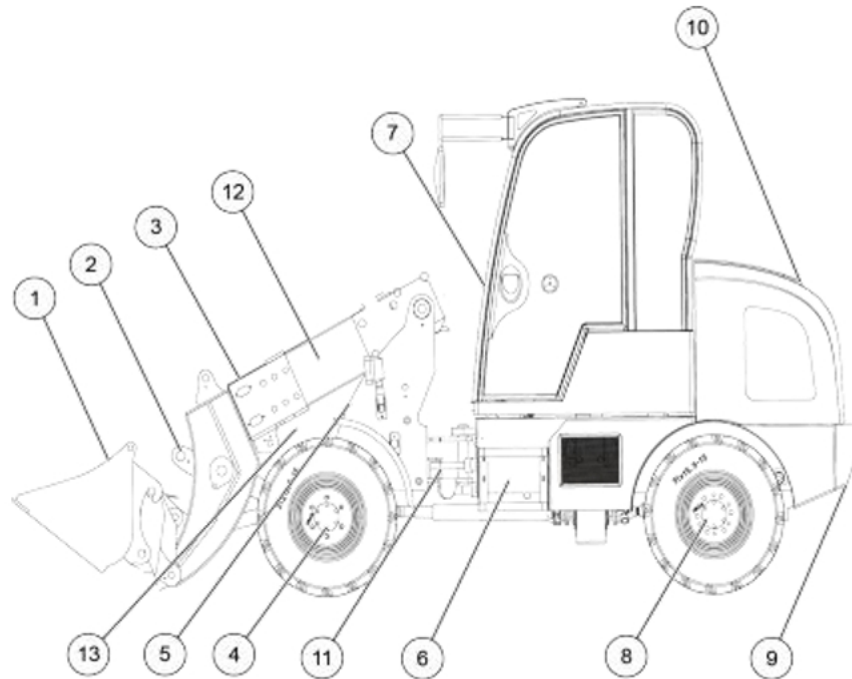

- (1) Bucket (2) Rocker arm (3) Lift arm (4) Front drive axle (5) Front frame
(6) Rear frame (7) Cab (8) Rear drive axle (9) Balance weight (10) Engine hood
(11) Steering cylinder (12) Tilting cylinder (13) Lifting cylinder

The functions of each component are described as follows:

- (1) Bucket: A kind of working accessory;
(2) Rocker arm: Tilt bucket;
(3) Lift arm: Lift bucket;
(4) Front drive axle: Transfer torque to the front wheels;
(5) Front frame: Bear work accessory;
(6) Rear frame: Bear engine, cab, etc.;
(7) Cab: Provide protection for the driver;
(8) Rear drive axle: Transfer torque to the rear wheels;
(9) Balance weight: Keep the loader weight balanced;

(10) Engine hood:Protect engine and persons;

(11) Steering cylinder:Provide steering power for the loader;

(12) Tilting cylinder:Provide bucket tilting power;

(13) Lifting cylinder:Provide bucket lifting power.

The optional attachments of the loader are shown in Table 4-1. It can be equipped with different attachments according to different working scenes and tasks.

Table 4-1 The optional attachments of the loader

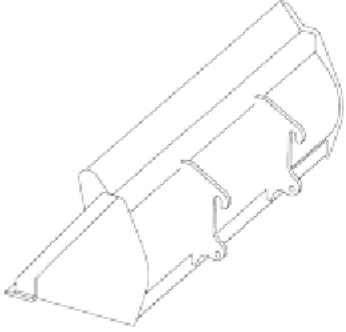
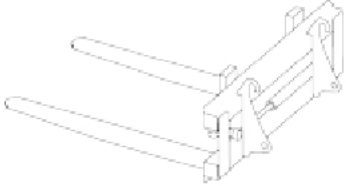
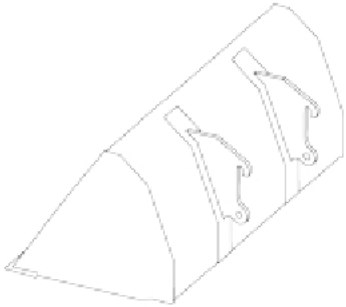
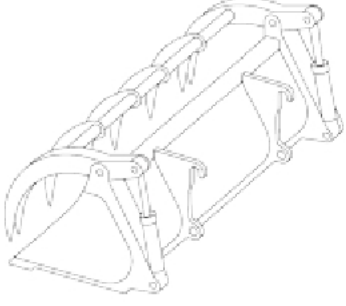
No.	Name	Icon	Function
1	Bucket		Load and unload bulk and block materials; Level the land, etc.
2	Hydraulic fork		Lift cargo; Load and unload cargo
3	Snow bucket		Remove snow
4	Grab bucket		Load and unload hay, timber, etc.

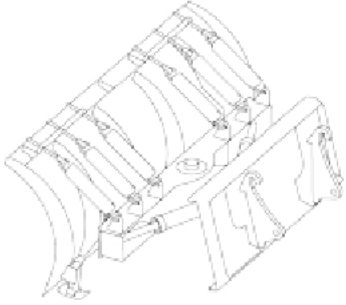
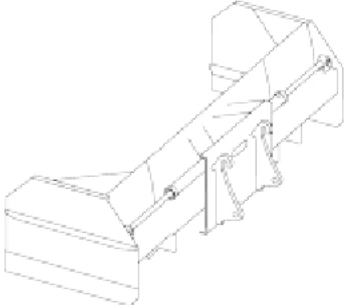
5	Obstacle avoidance snowboard		Remove snow and adjust the angle of the snowboard to avoid obstacles
6	Telescopic snowboard		Remove snow and adjust the width of the snowboard to avoid obstacles

4.2 Technical parameters

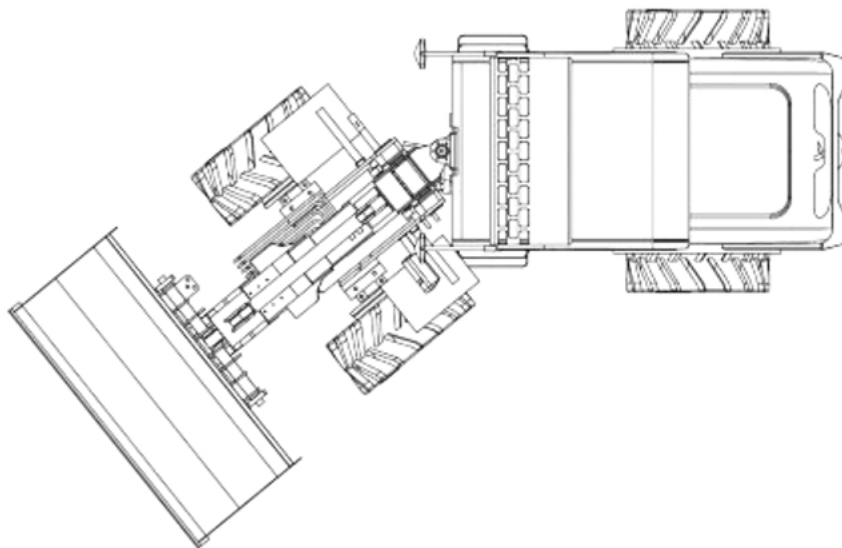
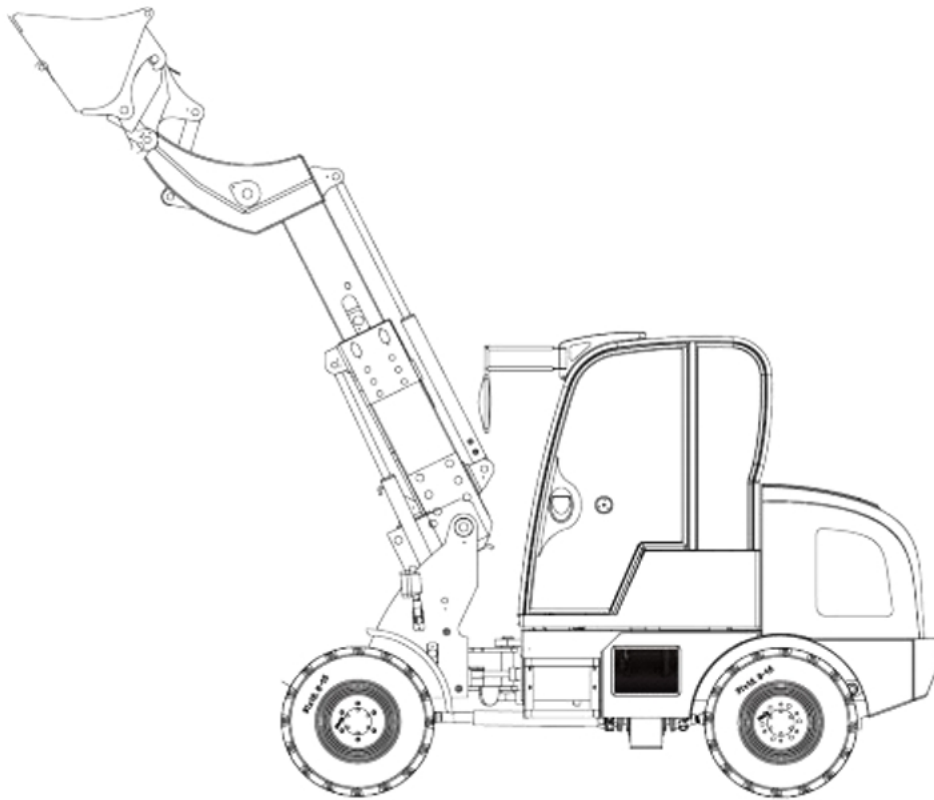

The technical parameters of loader are shown in Table 4-2.

Table 4-2 Technical parameters

Technical parameters (Unit)	Value
Length A(mm)	4610
Width P(mm)	1270
Height F(mm)	2450
Minimum ground clearanceS(mm)	227
Wheelbase D(mm)	2145
Minimum turning radius outside bucket U(mm)	3830
Maximum swing angle W(°)	40.01
Maximum loading height M(mm)	3446
Dumping distance N(mm)	1377
Rated capacity of the bucket(m ³)	0.5
Rated load(kg)	1000-1100
Maximum traction force(N)	>48kN
Tire inflation pressure(kPa)	300

5 Operation

5.1 Safety precautions

Read this section for safety precautions of the loader operation.

 WARNING	<ul style="list-style-type: none">• Only authorized personnel who is qualified in safety and skill training can operate the machine.• Do not wear loose coats, longhair, rings, watches, bracelets, ties, scarves and other accessories. Operators must make sure that the sleeves are fixed.• In order to explain the operation of the loader, some illustrations may not describe the complete safety functions, such as shields. Make sure that all these items are in place before start.
--	--

5.2 Introduction of operation terminal

5.2.1 Operation terminal overview

The operation terminal layout is shown in Figure 5-1.

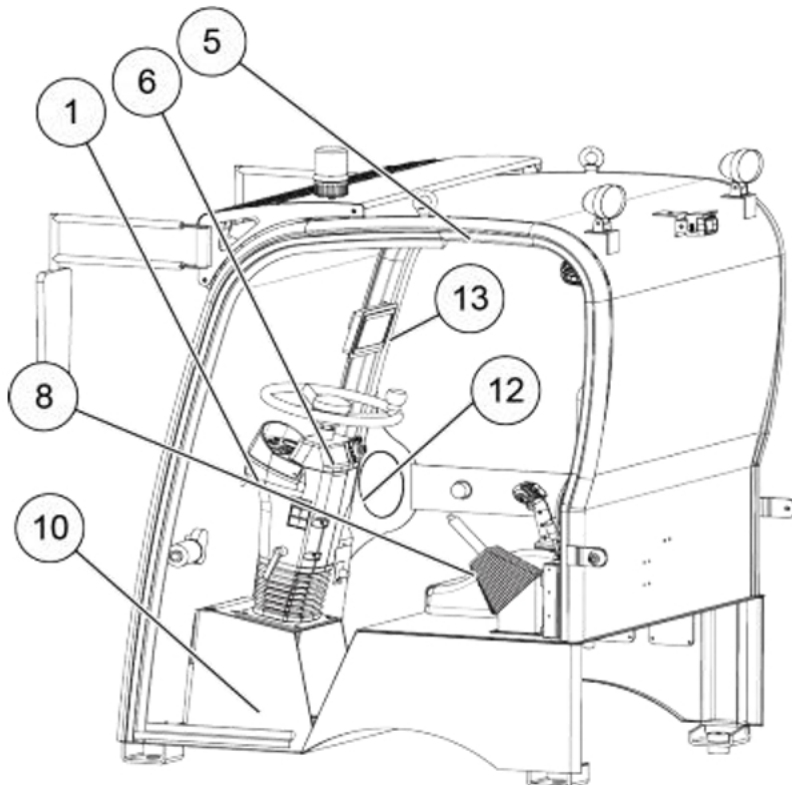

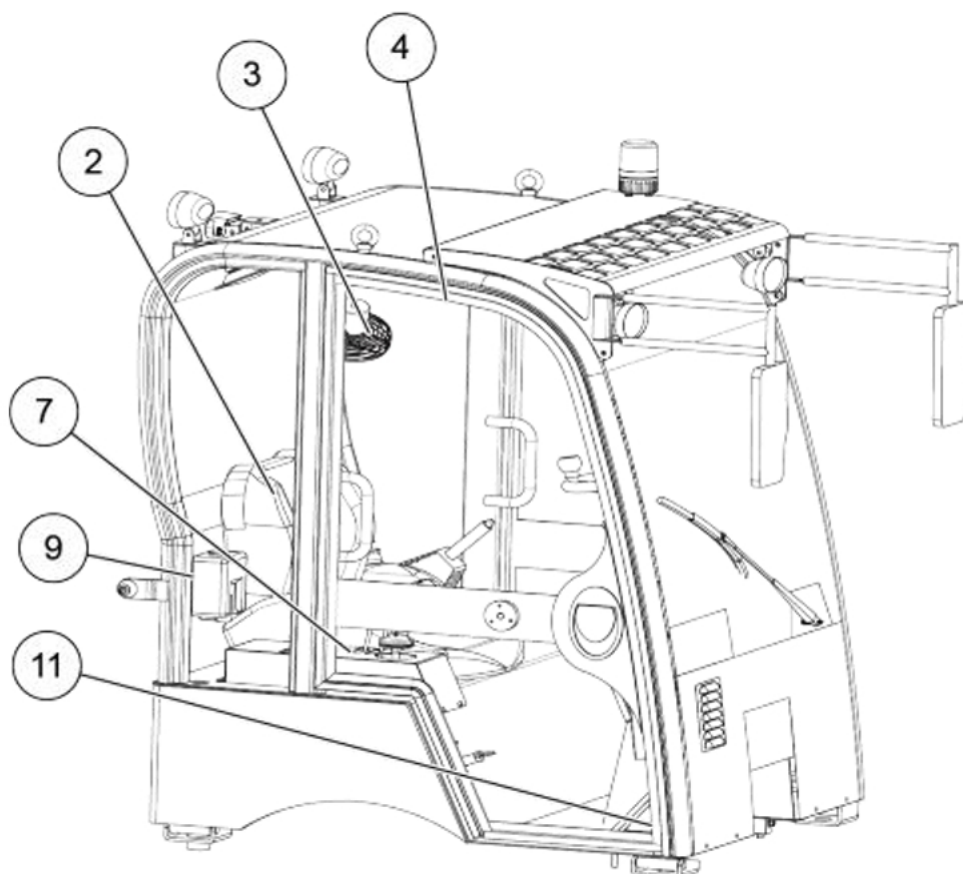

- (1) Steering column (2) Seat (3) Fan (4) MP3 (5) Light
(6) Operation platform (7) Power switch (8) Parking brake handle (9) Extinguisher
(10) Brake pedal (11) Accelerator pedal (12) Hot air adjusting knob (13) Backup camera

Operation and function of the terminal are shown in Table 5-1.

Table 5-1 Operation and function of the terminal

No.	Name	Operation and function
1	Steering column	Details refer to <i>chapter 5.2.2 Steering column A</i> and <i>chapter 5.2.3 Steering column B</i>
2	Seat	Details refer to <i>chapter 5.2.4 Seats</i>
3	Fan	Turn the fan on or off and adjust the fan speed
4	MP3	Details refer to MP3 instruction
5	Light	Turn on and off the cab light
6	Operation platform	Details refer to <i>chapter 5.2.5 Operation platform A</i> and <i>chapter 5.2.6 Operation platform B</i>
7	Power switch	Turn on or off the vehicle power
8	Parking brake handle	Tighten the handle to achieve parking brake; loosen the handle to release the parking brake
9	Extinguisher	Details refer to extinguisher instruction
10	Brake pedal	Depress the pedal to brake
11	Accelerator pedal	Depress the pedal to increase the fuel supply of the engine
12	Hot air adjusting knob	Turn on or off the hot air and adjust the air volume
13	Backup camera	When reversing, it opens automatically, so that the driver can check the situation behind the loader

5.2.3 Steering column B

The layout of steering column B is shown in Figure 5-8 and Figure 5-9.

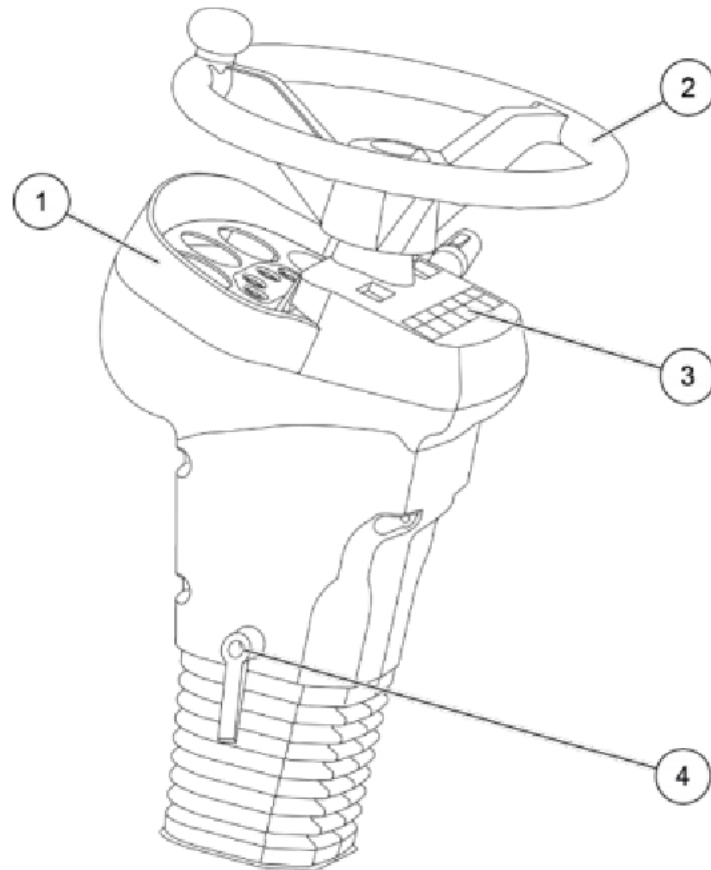

(1)Dashboard (2) Steering wheel (3) Other operation switch

(4) Steering wheel adjustment handle

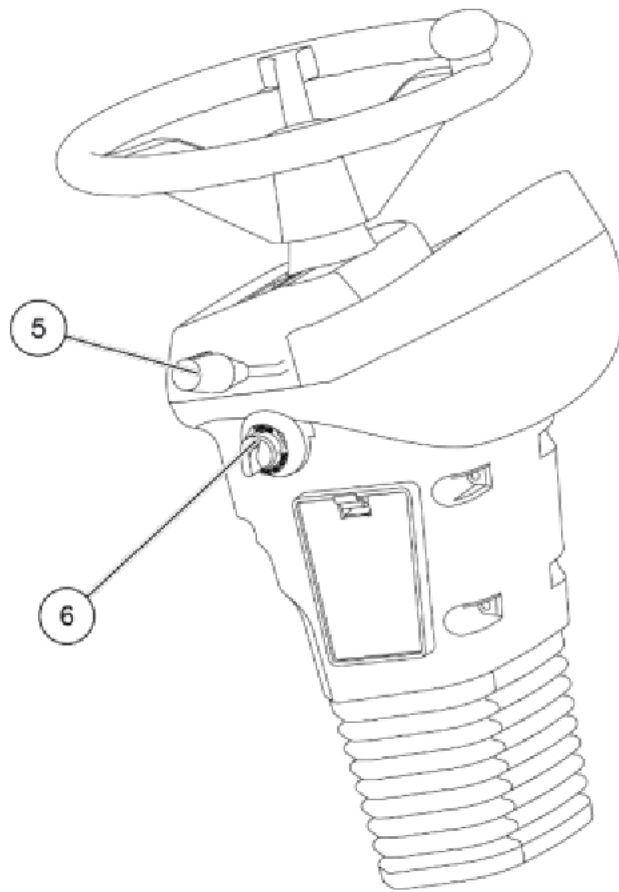

(5) Light control unit (6)Starting switch

The function description of steering column B is shown in Table 5-6.

Table 5-6 Function Introduction

No.	Name	Function Introduction
1	Dashboard	Display the loader data
2	Steering wheel adjustment handle	After adjusting the angle of the steering wheel, the steering wheel can be locked by the handle
3	Other operation switch	Control windshield wiper, working lights, ect.
4	Steering wheel	Control the running direction of the loader
5	Light control unit	Control turn lights and floodlights
6	Starting switch	Control the circuit of the loader and the engine start/stop

(1) Dashboard

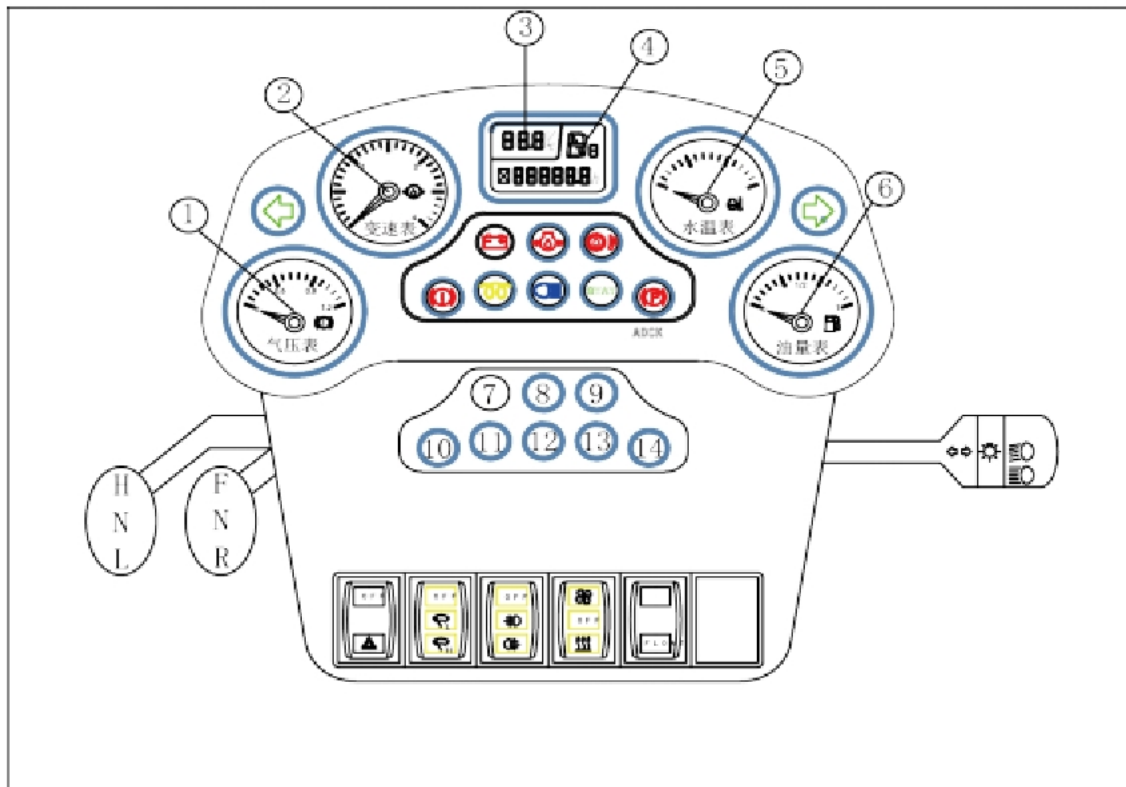

序号	图标	功能及说明	序号	图标	功能及说明
1		air pressure	11		warm-up indicator
2		torque converter pressure	12		high beam indicator
3		voltage and oil temperature	13		start indicator
4		gear	14		hand brake indicator
5		water temperature			
6		fuel gauge			
7		battery			
8		engine oil alarm indicator			
9		oil temperature alarm indicator			
10		inductive air pressure			

(2) Other operation switches

Other operationswitches are shown in Figure 5-11.

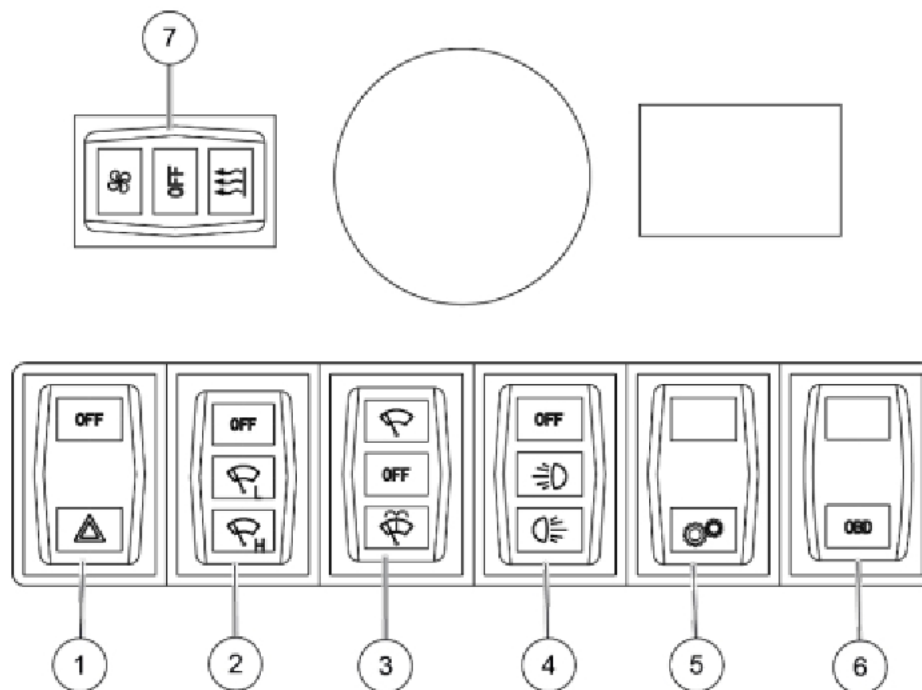

The operation and function descriptions of the other switches are shown in Table 5-8:

Table 5-8 The operation and function descriptions of the other switches

No.	Icon	Function	No.	Icon	Function
1		Control alert indicator	5		Switch power

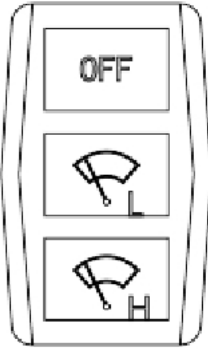
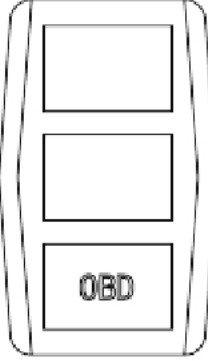
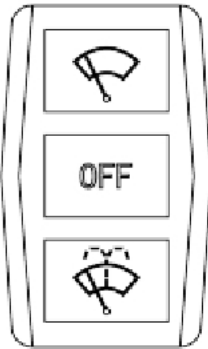
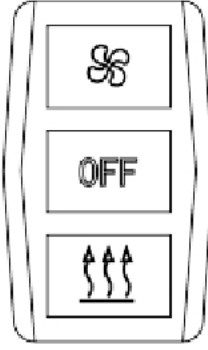
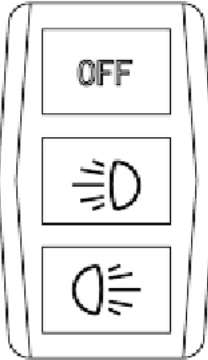
2		Switch of high speed, low speed and close of wiper	6		OBD switch
3		Switch of cleaning glass without cleaning fluid and using cleaning fluid	7		Switch of warm air and natural air
4		Switch of front and rear working lights	-	-	-



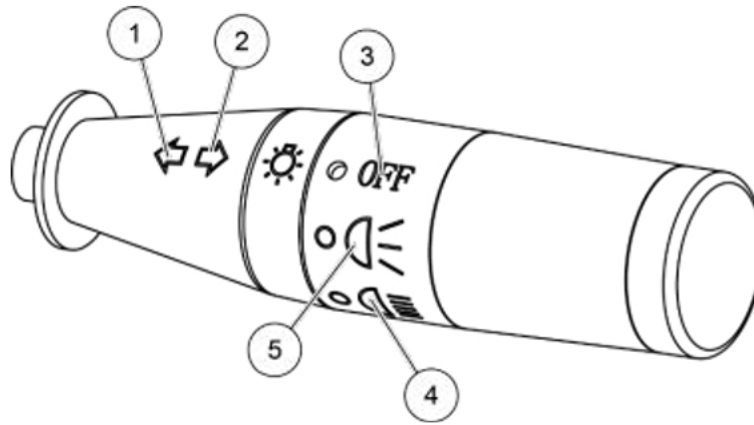

(3) Light operation unit

Light operation unit is shown in Figure 5-12.



The operation and function descriptions of the unit are shown in Table 5-9:

Table 5-9 The operation and function descriptions of the unit

No.	Icon	Operation and function
1		Turn the light control unit to the left, the left turn light turns on
2		Turn the light control unit to the right, the right turn light turns on
3		When the light control unit is rotated to "OFF", the floodlights of the loader is turned off
4		When the light control unit is rotated to the light beam state, the high beam lights of the loader is turned on
5		When the light control unit is rotated to the low beam state, the low beam lights of the loader is turned on

(4) Starting switch

Starting switch is shown in Figure 5-7.

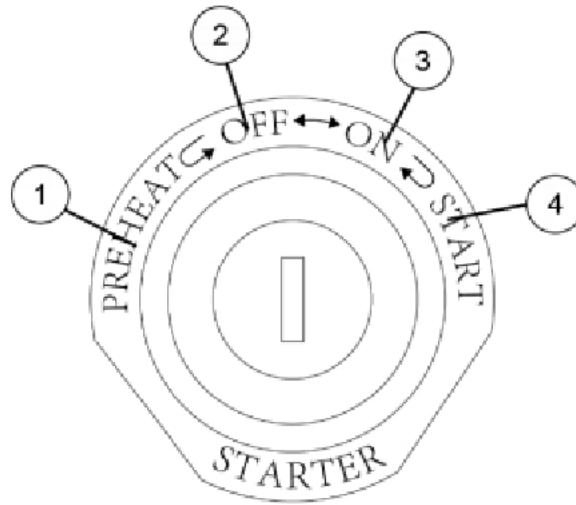

(1)Preheat (2)Off (3)On (4)Start

Starting switch is used to control the circuit on and off, control the start and stop of the engine and control the preheating of the engine. The function is shown in Table 5-5:

Table 5-5 The function description of starting switch

No.	Name	Operation and function
1	Preheat	<ul style="list-style-type: none"> • When the key is rotated from "OFF" to this position, the cold start device will preheat the engine; • Preheat time is not allowed to exceed 50 seconds.
2	Off	<ul style="list-style-type: none"> • Only in this gear, the key can be inserted and removed; • When the starting switch is in this position, the circuit is off and the engine stops.
3	On	<ul style="list-style-type: none"> • When the key is rotated from "OFF" to this position, the circuit of the loader is on; • After the engine starts, the key reset to "ON".
4	Start	<ul style="list-style-type: none"> • When the key is rotated from "ON" to this position, the starting motor will start the engine; • After engine starts, immediately release the key, the key will reset to "ON"; • Start time should not exceed 10 seconds, and the interval between starts should be at least 2 minutes.

5.2.4 Seat

The seat of the loader is shown in Figure 5-13.

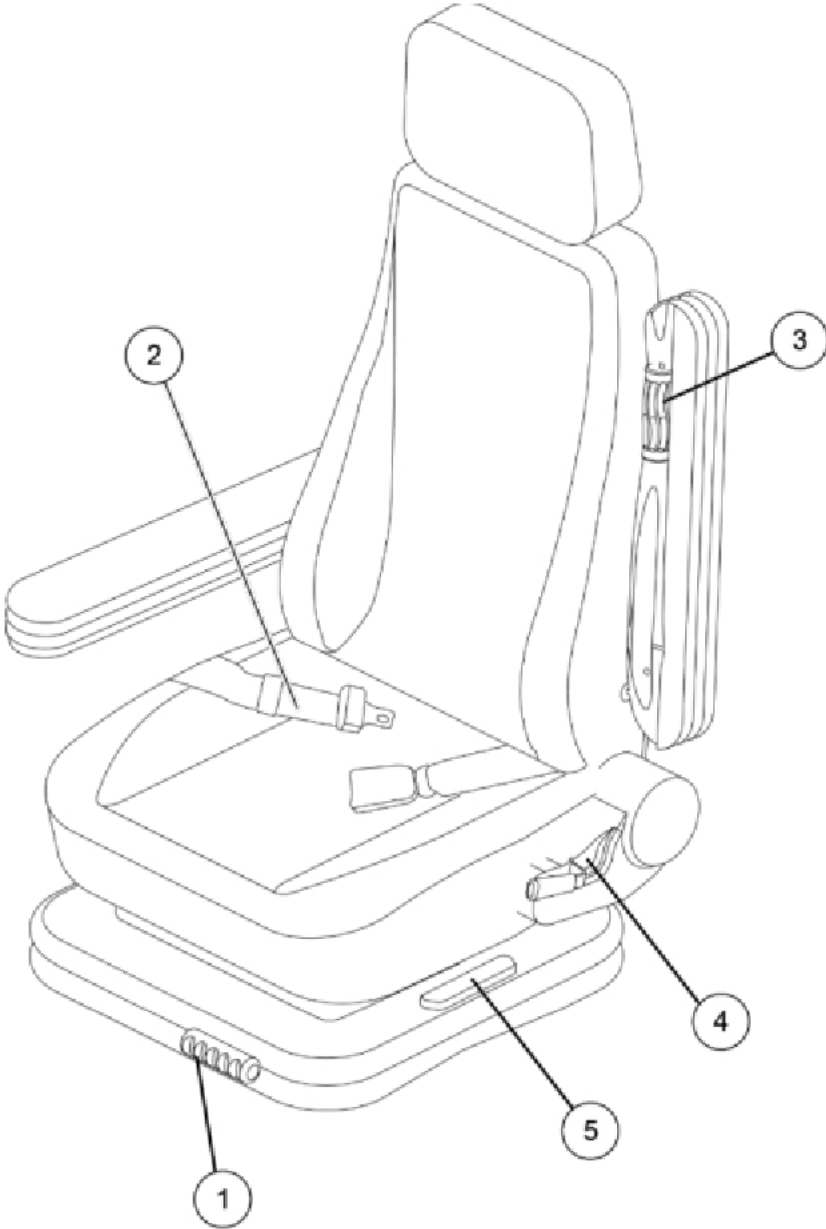

The operation and function descriptions of the seat are shown in Table 5-10.

Table 5-10 The operation and function descriptions of the seat

No.	Name/Function	Operation
1	Hardness control handles	<ul style="list-style-type: none"> • Pull out the handle (1) and adjust the seat hardness by rotating the handle (1).
2	Belt	<ul style="list-style-type: none"> • Raise the handrail and adjust the height of the handrail by rotating the knob (3) to different positions.
3	Handrail height adjusting knob	<ul style="list-style-type: none"> • Raise the handrail and adjust the height of the handrail by rotating the knob (3) to different positions.
4	Backrest tilt angle adjustment handle	<ul style="list-style-type: none"> • Lift the handle (4), adjust the tilt of the backrest to an appropriate position, then release the handle (4).
5	Front and rear seat position adjustment handle	<ul style="list-style-type: none"> • Lift handle (5), adjust the seat to an appropriate position, then release handle (5).
6	Seat height adjustment	<ul style="list-style-type: none"> • The height of the seat has three clamping positions, which can be adjusted according to the need; • When adjusting, hold the base under the cushion with both hands lifting it up smoothly. The seat will reach the clamping position when moving up. At this time, loose your hands and the seat will be fixed in this position; • If the seat position is adjusted to the highest position, and then forced to pull up, and then press down, at this time the seat will fall to the lowest position.

5.2.5 Operation platform A

The operation platform A layout is shown in Figure 5-14.

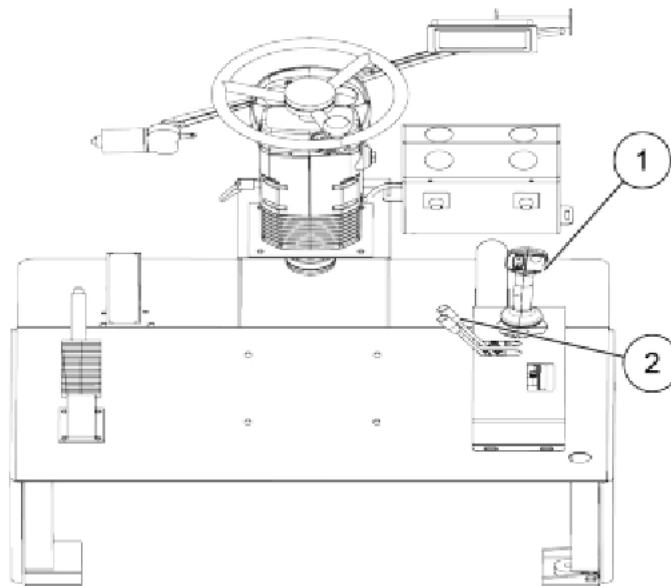

(1) Control handle (2) Quick change cylinder switch

The function description of console A is shown in Table 5-11.

Table 5-11 Function Introduction

No.	Name	Function and operation
1	Control handle	Control the lifting height and tilting angle of the bucket. For the function and use method refer to below contents in this chapter
2	Quick change cylinder switch	Quick change cylinder switch can self reset, control the extension and retraction of quick change cylinder

(1)Control handle

1) The control lever has five working positions: front, rear, left, right and center. The function and operation of the handle are shown in Table 5-12.

Table 5-12 Function and operation of the control lever

No.	Working position	Function
1	Front	The bucket tilts forward to perform unload action
2	Rear	The bucket tilts back to perform the bucket collection
3	Left	The bucket raise
4	Right	The bucket down
5	Center	The bucket is kept in a fixed position

2) The travel control switch has three working positions. The function and operation are shown in Table 5-13.

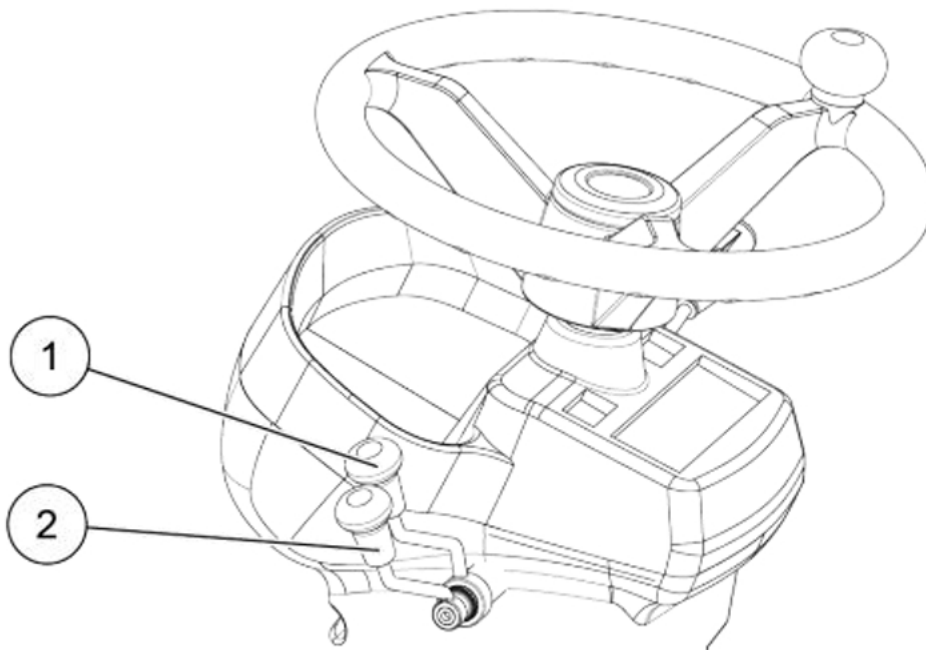

1. Gear for Front and rear

2. Gear for high and low speed

Table 5-13 Function and operation of the travel control switch

No.	Position	Function	Operation
1	Front	Drive	<ul style="list-style-type: none"> • The left foot press the brake pedal to reduce the loader speed to 0, • Release the brake pedal with the left foot and press the accelerator pedal slowly with the right foot, then the loader moves forward.
2	Center	Neutral	<ul style="list-style-type: none"> • The left foot presses on the brake pedal to reduce the loader speed to 0,
3	Rear	Reverse	<ul style="list-style-type: none"> • The left foot press the brake pedal to reduce the loader speed to 0, • Release the brake pedal with the left foot and press the accelerator pedal slowly with the right foot, then the loader moves backwards.

 WARNING	<ul style="list-style-type: none"> • Do not transfer the travel control switch when the loader is walking.
--	---

3) High-low speed button

Press the high-low speed button, the loader can switch between high and low speed

 WARNING	<ul style="list-style-type: none"> • Only when the speed is 0, you can press the high-low speed button to switch the speed.
--	--

5.3 Typical operating procedures

5.3.1 Start (above 6°C)

	<ul style="list-style-type: none">• Make sure that all safeguards in place, and no fault.• Check fuel oil, lubricating oil and hydraulic oil systems for leaks.• Check the level for coolant, fuel oil and engine oil.• Check the battery voltage, make sure that the voltage is not less than 24V.• Clean all windows and lights, and adjust the reflector position to ensure a good view.
---	---

When the temperature is higher than 6°C, the operation steps of the loader start are as follows:

Step 1: Turn on the power switch (1) in the cab

(1) Power switch

Step 2: Get on the loader, adjust the seat to a comfortable state and fasten the belt. Details refer to *chapter 5.2.4 Seats*;

Step 3: Insert the key into the starting switch (3), the ignition switch is in "OFF" state (4), as shown in Figure 5-23;

Step 4: Check and make sure that the travel control switch (2) is in the middle position, as shown in Figure 5-22;

(2) Travel control switch (3) Starting switch

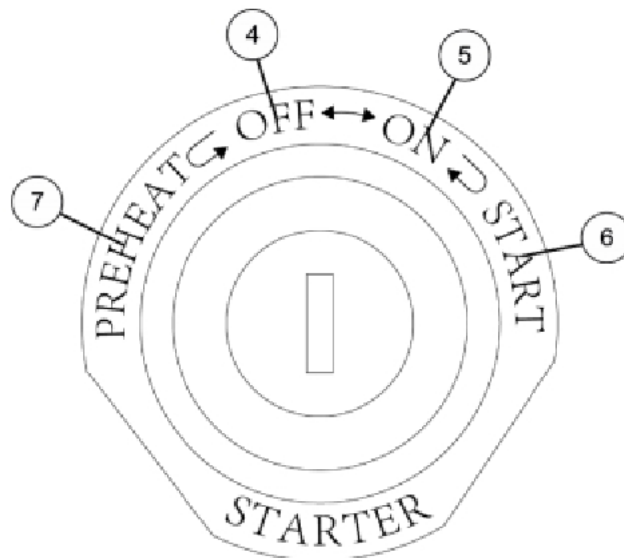

Step 5: Turn the key to the "ON" state(5) and hold. At this time, the whole loader circuit is connected;

Step 6: Continue to turn the key to the "START" state(6), the starter drives the engine to run; After the engine starts, release the key, and the key will automatically return to the "ON" state(5). Notice: Do not start the engine continuously for more than 10 seconds each time, and the interval between two starts is at least 2 minutes.

5.3.2 Start (below 6°C)

 WARNING	<ul style="list-style-type: none"> • Make sure that all safeguards in place, and no fault. • Check fuel oil, lubricating oil and hydraulic oil systems for leaks. • Check the level for coolant, fuel oil and engine oil. • Check the battery voltage, make sure that the voltage is not less than 24V. • Clean all windows and lights, and adjust the reflector position to ensure a good view.
--	---

When the temperature is below 6°C, but above -10°C, the operation steps of the loader start are as follows:

Step 1: Turn on the power switch (1) in the cab,

(1) Power switch

Step 2: Get on the loader, adjust the seat to a comfortable state and fasten the belt. Details refer to

chapter 5.2.4 Seats;

Step 3: Insert the key into the starting switch (3), the starting switch is in "OFF" state(4), as shown 5-26;

(2) Travel control switch (3) Starting switch

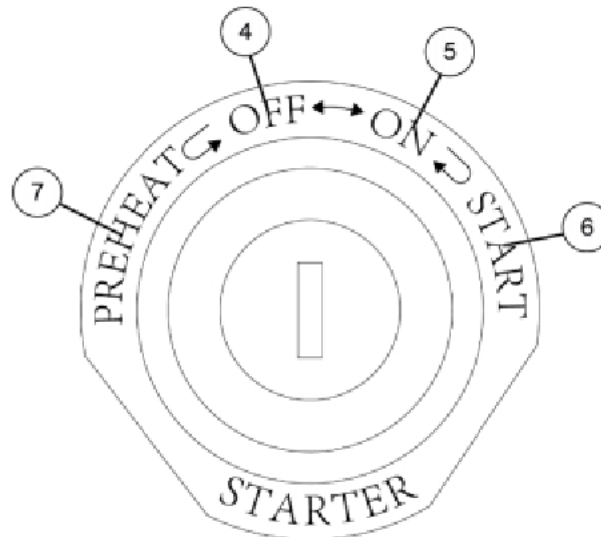

Step 4: Check and make sure that the travel control switch (2) is in the middle position, as shown in Figure 5-25;

Step 5: Turn the starting switch (3) to "PREHEAT" state(7) to preheat the engine. The preheat time shall not exceed 50 seconds. After preheating, release the starting switch, and the starting switch will automatically reset to "OFF" state;

Step 6: Turn the key to "ON" state (5) and hold. At this time, the whole loader circuit is connected;

Step 6: Continue to turn the key to "START" state (6), the starter drives the engine to run; After the engine starts, release the key, and the key will automatically return to "ON" state(5). Notice: Do not start the engine continuously for more than 10 seconds each time, and the interval between two

starts should be at least 2 minutes.

5.3.3 Start (below -10°C)

 WARNING	<ul style="list-style-type: none">• Make sure that all safeguards in place, and no fault.• Check fuel oil, lubricating oil and hydraulic oil systems for leaks.• Check the level for coolant, fuel oil and engine oil.• Check the battery voltage, make sure that the voltage is not less than 24V.• Clean all windows and lights, and adjust the reflector position to ensure a good view.
--	---

When the temperature is below -10°C, the operation steps of the loader start are as follows:

Step 1: Connect the power of the preheater (1) to preheat the engine for 15 minutes, as shown in Figure 5-27;

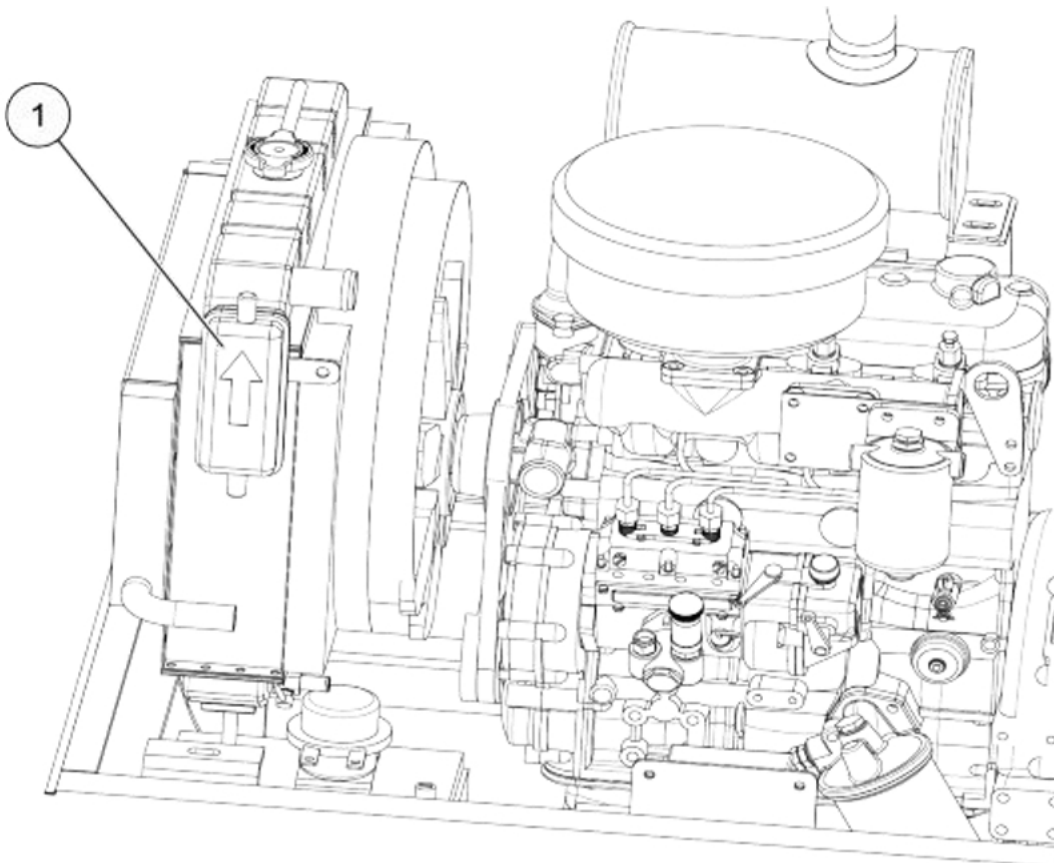

(1) Engine preheater

Step 2: Turn on the power switch

(2) Power switch

Step 3: Get on the loader, adjust the seat to a comfortable state and fasten the belt. Details refer to *chapter 5.2.4 Seats*;

Step 4: Insert the key into the starting switch, the starting switch is in "OFF" state(5), as shown in Figure 5-30;

(3) Starting switch (4) Travel control switch

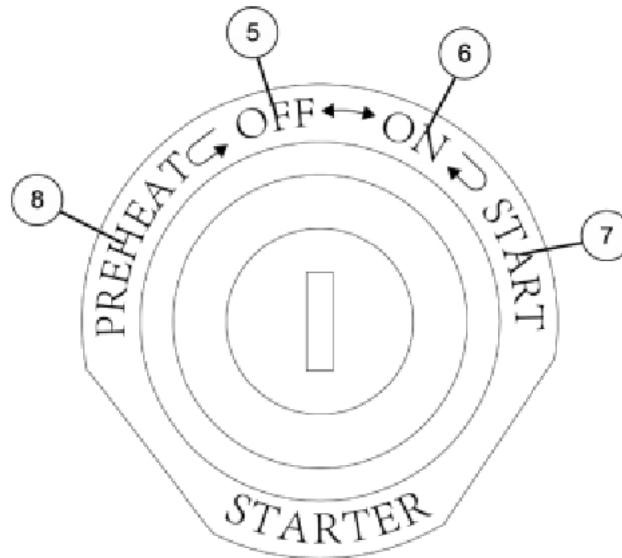

Step 5: Check and make sure that the travel control switch (4) is in the middle position,

Step 6: Turn the key to "ON" state(6) and hold. At this time, the whole loader circuit is connected;

Step 7: Continue to turn the key to "START" state(7), the starter drives the engine to run; After the engine starts, release the key, and the key will automatically return to the "ON" state(6). Notice: Do not start the engine continuously for more than 10 seconds each time, and the interval between two starts should be at least 2 minutes.

5.3.4 Parking

 WARNING	<ul style="list-style-type: none">• Avoid parking on a slope as far as possible. If it is necessary to park on a slope, make sure that the loader front is down and put a wedge under the wheel to prevent the car from slipping.• Before pulling up the brake handle to the braking position, keep pressing the brake pedal
--	---

Step 1: Remove the material in the bucket;

Step 2: Select the parking position of the loader, choose a flat ground as far as possible, and put the bucket (1) to the ground, as shown in Figure 5-31;

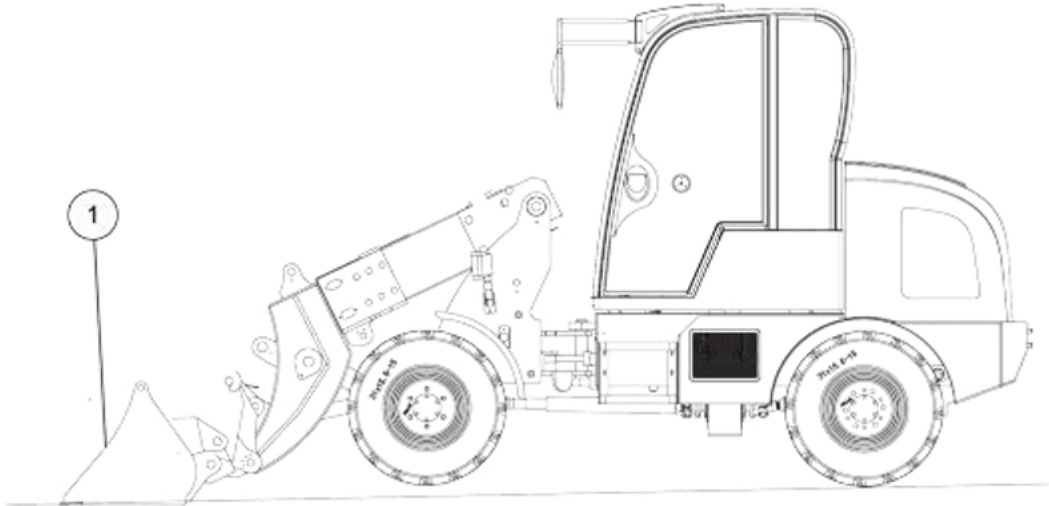

(1) Bucket

Step 2: Release the accelerator pedal (3), depress the brake pedal (2), and put the travel control switch (4) in the middle position, as shown in Figure 5-32 ;

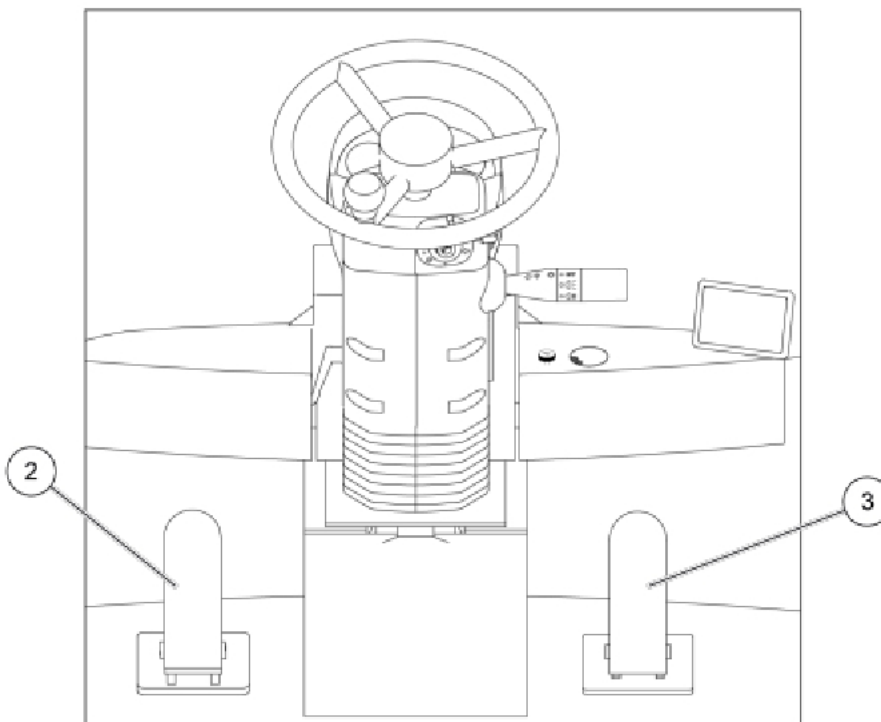

Step 3: Pull up the brake handle (5) to the braking position and release the brake pedal (2), as shown in Figure 5-34;

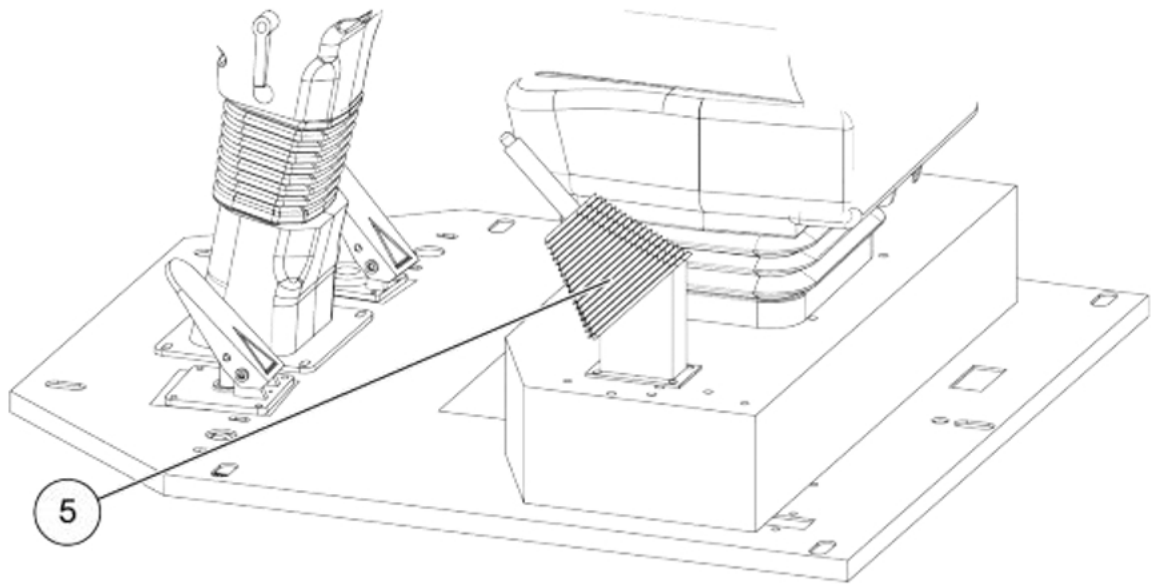

(5) Brake handle

Step 4: Turn the starting switch to "OFF" state(6) in order to stop the engine, as shown in Figure 5-35;

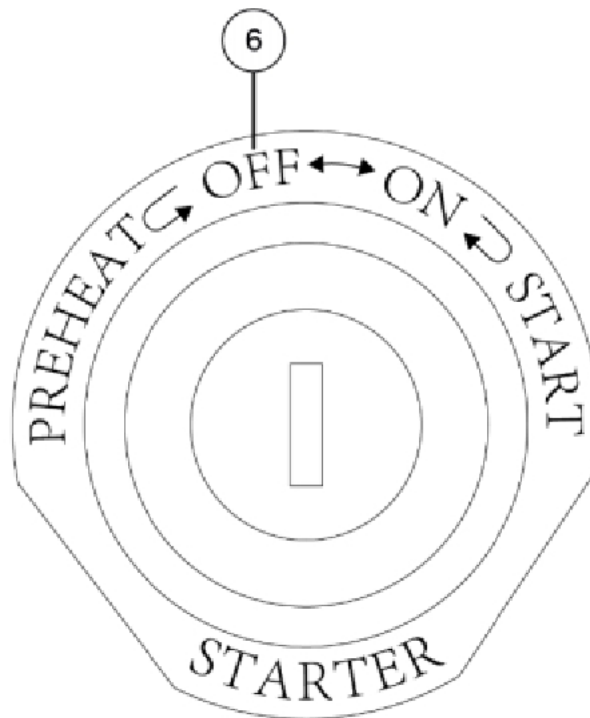

5.3.5 New loader run-in

	<ul style="list-style-type: none">• Avoid heavy load or high-speed operation during the run-in of the new loader.• Observe and adjust the state of the loader at any time during the run-in of the new loader, and deal with any abnormal problems in time or contact the supplier.
---	--

Before using the new loader, the new loader must be run in first, the purpose is to make the friction parts fully run-in to extend the service life of the machine. The run-in operation procedure of the new loader is as follows:

Step 1: Start the loader, run it at low speed in neutral for 5 minutes to make the engine fully preheated;

Step 2: Drive for two hours without load. Forward, backward, high-speed forward and high-speed backward should be evenly arranged from low speed to high speed. The loader should perform smooth left and right steering and braking when driving. Avoid sudden run, sudden acceleration, sudden steering and sudden braking except in emergency situations;

Step 3: Loading of loose materials (such as sand) for 8 hours, loading weight shall not exceed 70% of the rated weight, driving speed shall not exceed 70% of the maximum speed;

Step 4: After the new loader is run-in for 10 hours, inspect and maintain the loader according to the 10-hour inspection and maintenance items in *chapter 6.2.1 Inspection and maintenance list*.

5.3.6 Add fuel

	<ul style="list-style-type: none">• Avoid spillage when fueling. If there is a splash of fuel, should be thoroughly wiped clean, to prevent fire;• Fill up the standard diesel fuel, otherwise it will cause the fuel system failure;• Keep fuel tank full during cold weather to prevent water from condensing in the tank.
---	--

Step 1: Park the loader on a flat ground, put the control lever in neutral position, stop and pull up the parking brake handle;

Step 2: Carefully clean the area of the fuel tank cap (1) and unscrew the fuel tank cap (1) , as shown in Figure 5-36;

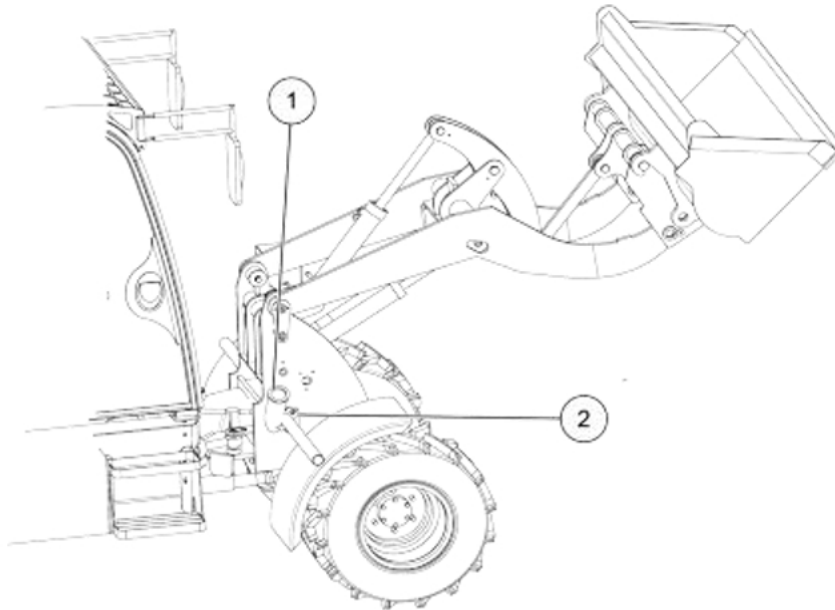

(1) Fuel tank cap (2) Level gauge

Step 3: Add fuel through the fuel injection port and observe the fuel level through the fuel level gauge (2). The fuel level cannot exceed the upper limit of the fuel level gauge;

Step 4: After refueling, tighten the fuel tank cap (1).

5.3.7 Add coolant

 WARNING	<ul style="list-style-type: none"> • High temperature and high pressure coolant can rush out of the radiator and cause serious burns. Before removing the radiator pressure cover , make sure that the engine stops and cools fully. • The cooling system operates under high pressure. Ensure that the pressure cover sealing ring is not damaged and securely tighten.
--	--

Step 1: Park the loader on a flat ground, put the control lever in neutral position, stop and pull up the parking brake handle, to make the engine cool fully;

Step 2: Carefully clean the pressure cap (1) at the top of the radiator, and slowly unscrew the pressure cover (1). as shown in Figure 5-37;

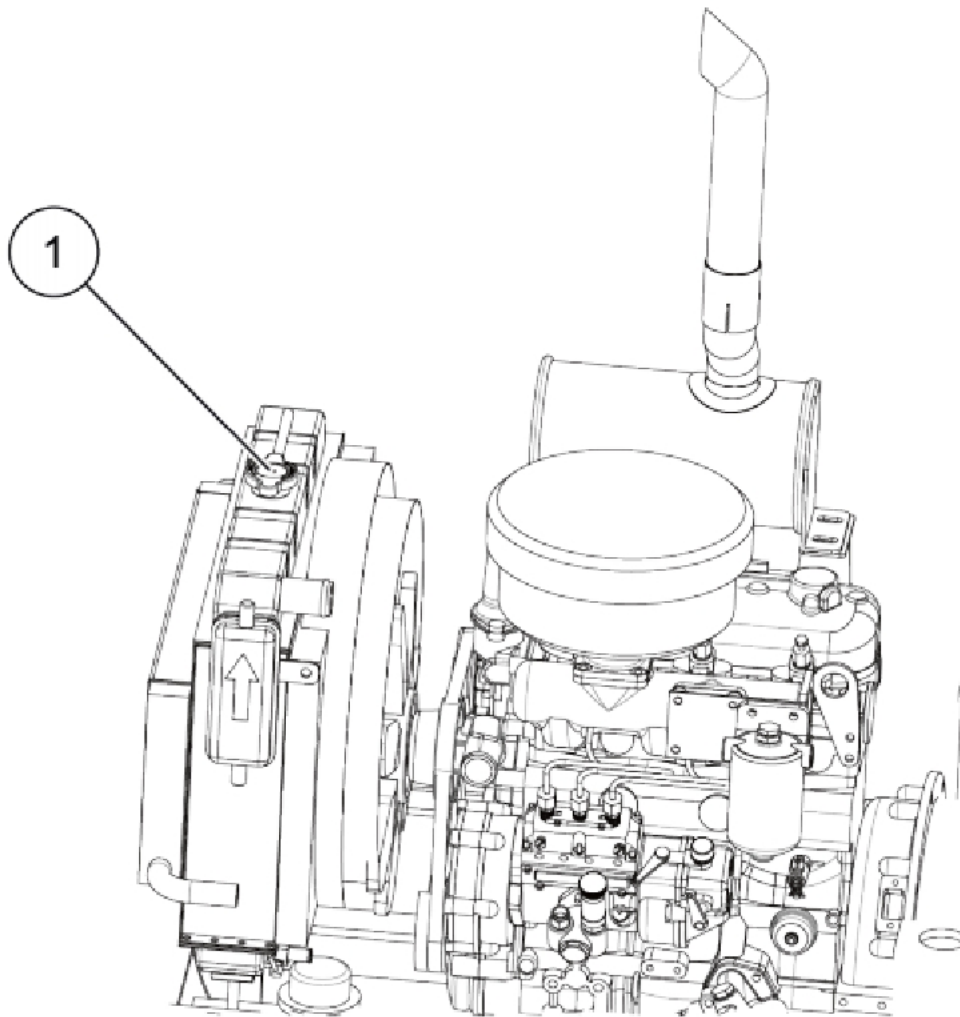

(1) The pressure cap

Step 3: Add coolant to the radiator until it is full, and then tighten the pressure cap(1);

Step 4: Start the loader, refer to *chapter 5.3.1 Start (Above 6°C)* or *chapter 5.3.2 Start (Below 6°C)* or *chapter 5.3.3 Start (Below -10°C)*, and let the engine run for 5 minutes to eliminate all air in the cooling system;

Step 5: Stop the machine and unscrew the pressure cap (1) again after the engine is fully cooled. If the liquid level drops, the coolant should be added until the radiator is full filled with the coolant.

5.3.9 Draining fuel filter

Step 1: Park the loader on a flat ground, put the control handle in neutral position, stop and pull up the parking brake handle;

Step 2: Open the engine cover;

Step 3: Unscrew the drain knob (1) under the fuel filter to drain until the yellow liquid (diesel) flows out, as shown in Figure 5-40;

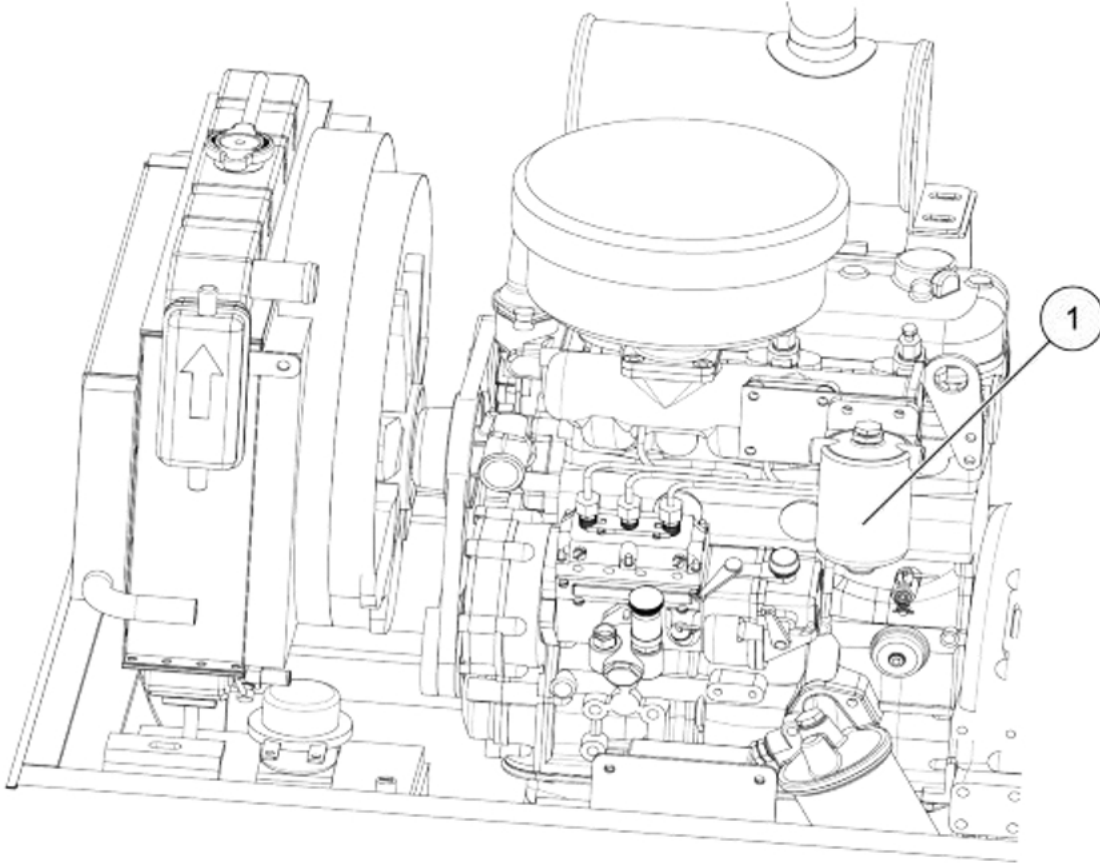

Step 4: Tighten the drain knob after draining.

5.3.10 Replace attachment

This type of the loader can be replaced accessories according to different operating situations. The following takes the replacement of the bucket as an example to illustrate the operating procedures for replacing different attachments:

Step 1: Select a flat ground, put the bucket (1) to the ground by operating the control handle, as shown in Figure 5-41;

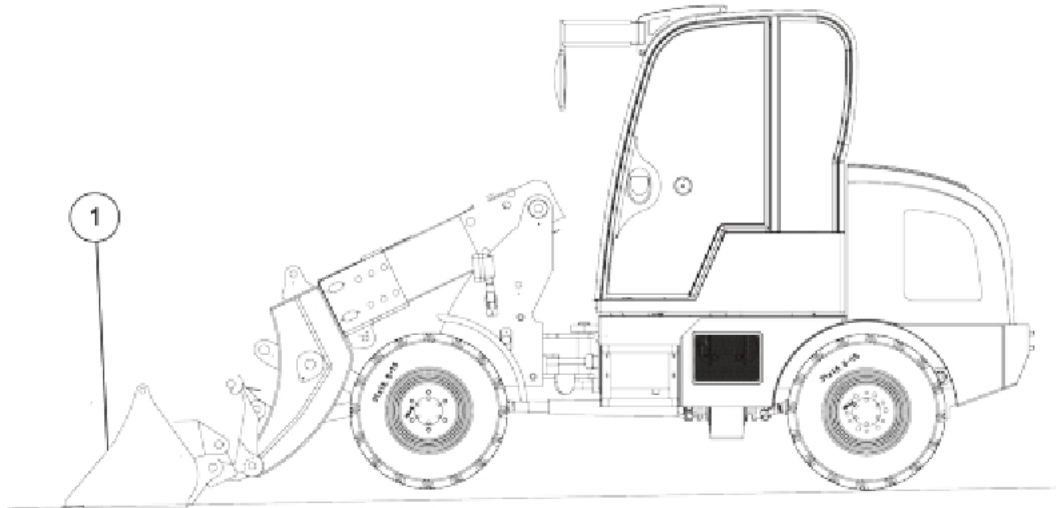

Step 2: If the replacement accessory is installed with a hydraulic motor, it is necessary to stop the engine, release the pressure of the working hydraulic oil, and then block the inlet and outlet of hydraulic tube and fix it;

Step 3: Pull backward with quick change cylinder switch (2), and set the quick change cylinder (4) to retracted state, as shown in Figure 5-42 and 5-43;

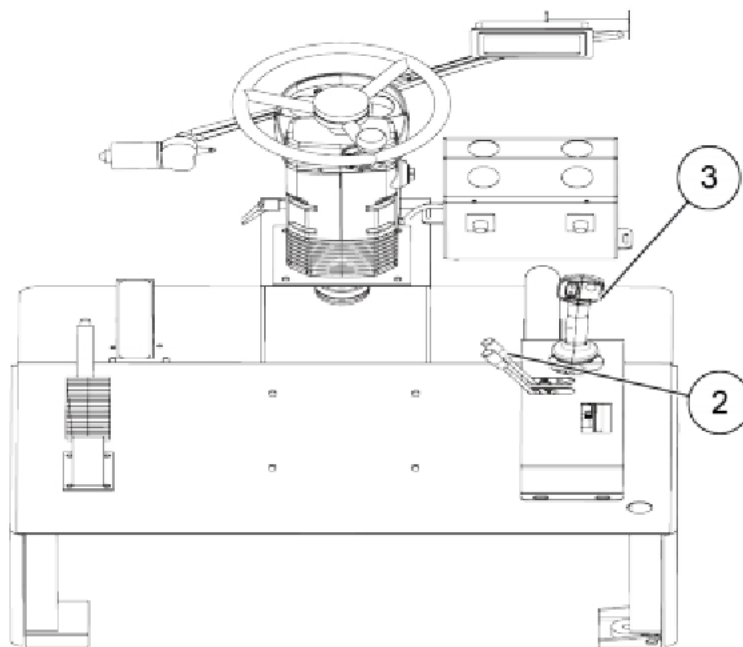

(2) Quick change cylinder switch (3) Control handle

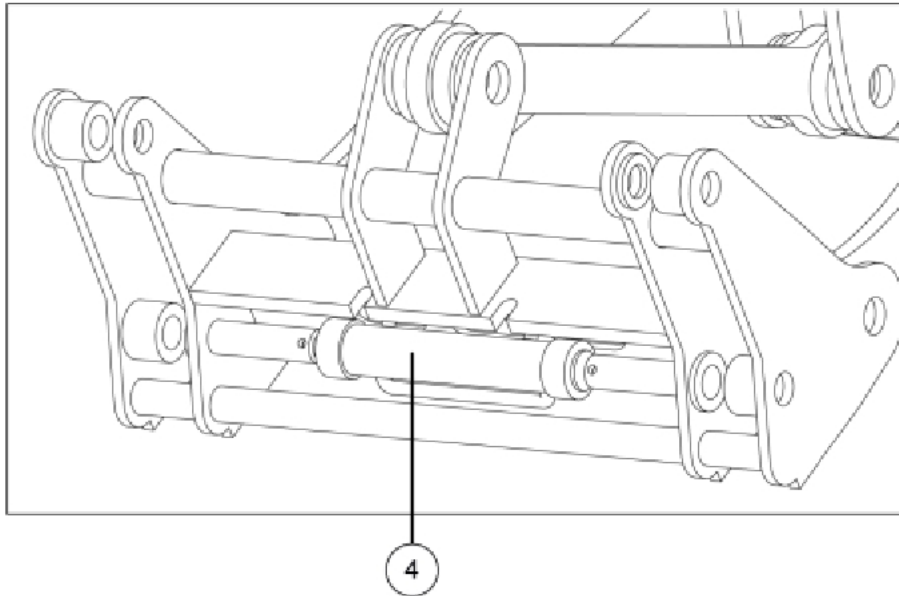

(4) Quick change cylinder

Step 4: Adjust the control handle (3) to make the pin (5) on the lift arm move downward away from the hanger(6) area of the bucket, as shown in Figure 5-44 below;

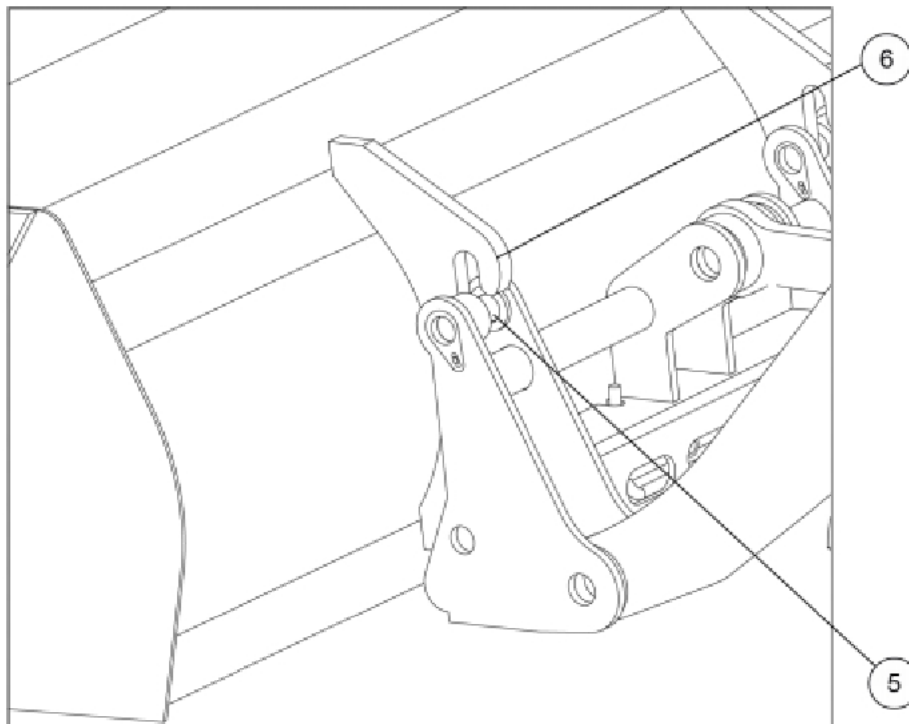

(5) Pin (6) Hanger

Step 5: Operate the control handle to make the loader exit the attachment replacement area backwards;

Step 6: Keep the posture of the loader unchanged, move the loader to the front of the new attachment, and operate the control handle to make the pins (5) on both sides of the lift arm contact the bucket hangers (6) at the same time;

Step 7: Move the control handle (3) and lift the arm vertically up;

Step 8: Pull the quick change cylinder switch (2) to make the piston rod (4) of the quick change cylinder stretch out to complete the replacement of the attachment .

5.3.11 Loading operation

 WARNING	<ul style="list-style-type: none">• Keep work area flat and remove falling rocks.
--	---

Step 1: Adjust the position of the loader relative to the stockpile, so that the loader is facing the stockpile;

Step 2: When the loader is moving forward and approaching the stockpile, put down the bucket, keep the bucket 30cm away from the ground, and stop the loader, as shown in Figure 5-45;

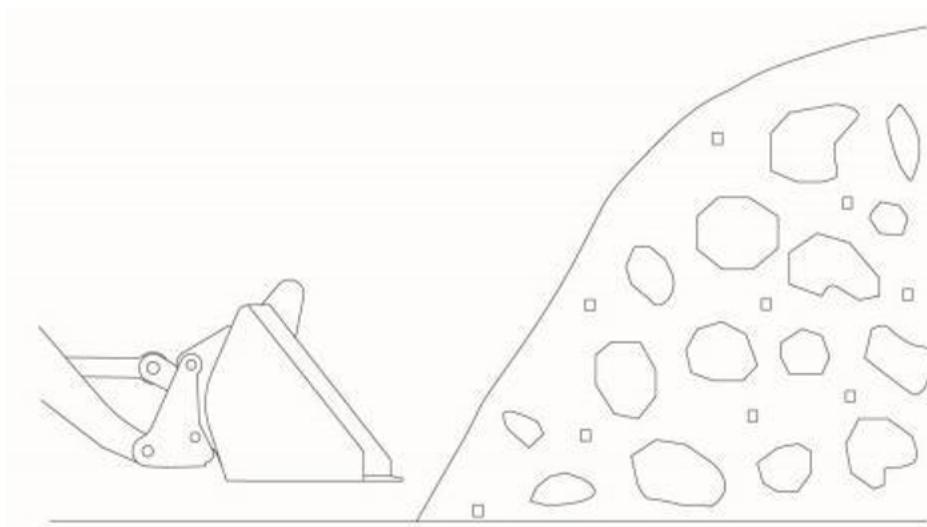

Step 3: Lower the bucket slowly so that it touches the ground. If the stockpile is loose material, put the bucket flat; If the pile is gravel, tilt the bucket slightly, as shown in Figure 5-46 and 5-47;

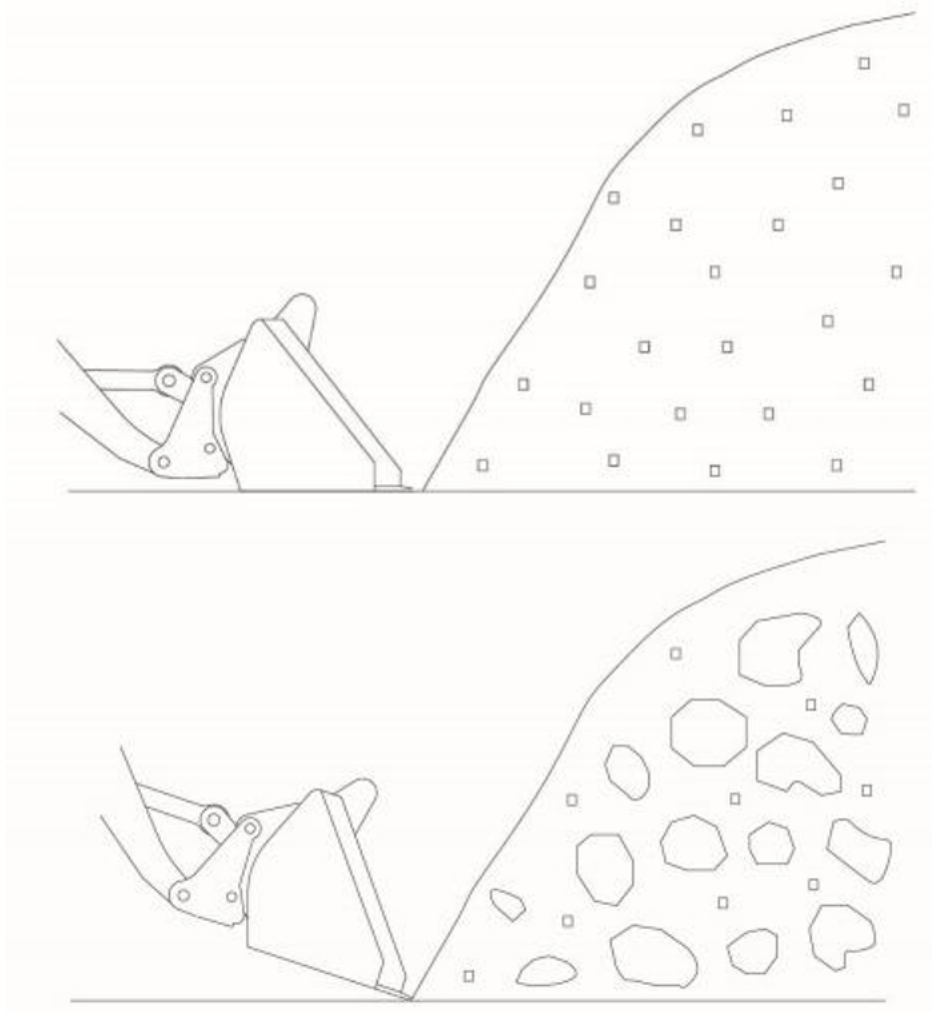

Step 4: Switch the loader's speed to low speed through the high-low speed button;

Step 5: Step on the accelerator pedal and insert the bucket into the stockpile. While the bucket is inserted into the stockpile, raise the boom slightly to keep the front tires with sufficient traction;

Step 6: When there is enough material in the bucket, control the handle to collect the bucket to fill the material. If there is too much material in the bucket, the bucket should be quickly tilted and collected to remove excess material to prevent material falling down when walking, as shown in Figure 5-48;

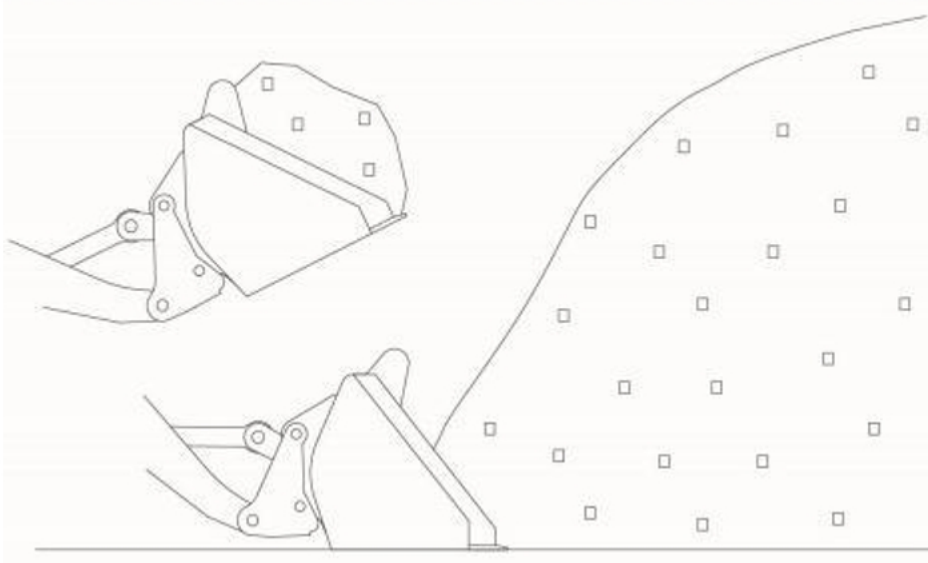

Step 7: When unloading the material to the truck or the stockpile, the loader approaches the unloading site, control the handle to lift the bucket. Make sure that the bucket is lifted to the required height, and ensure that the bucket and the stockpile are not touched when tilting forward to the maximum Angle;

Step 8: Push the handle forward to make the bucket tilt forward for unloading. When unloading, it is required to move slowly to reduce the impact of the material on the loader. When the material sticks to the bucket, operate the handle back and forth to make the bucket shake and remove the material, as shown in Figure 5-49;

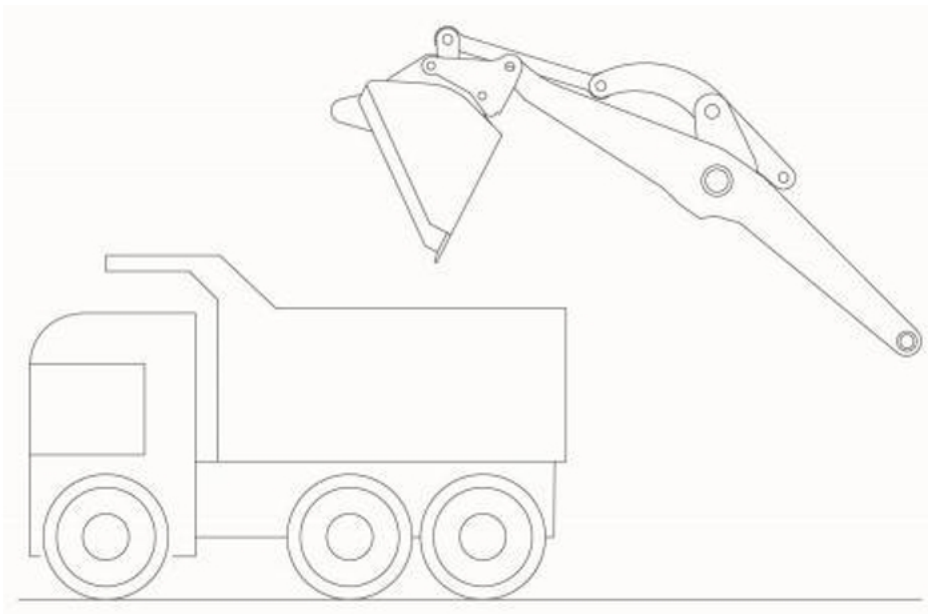

Step 9: After the unloading is complete, operate the handle to make the bucket flat to prepare for the next cycle operation.

5.3.12 Pushing operation

 WARNING	<ul style="list-style-type: none">• Pay close attention to the oil temperature of the working hydraulic oil when pushing. If the oil temperature is too high, it should be stopped for rest, and the operation should be carried out after the oil temperature drops.• Keep the bucket parallel to the ground when pushing the material, and do not make the bucket in the unloading position.
--	---

Step 1: Operate the handle to make the bucket is flat on the ground. The bucket posture is as shown in Figure 5-50, and step on the accelerator pedal to make the loader forward;

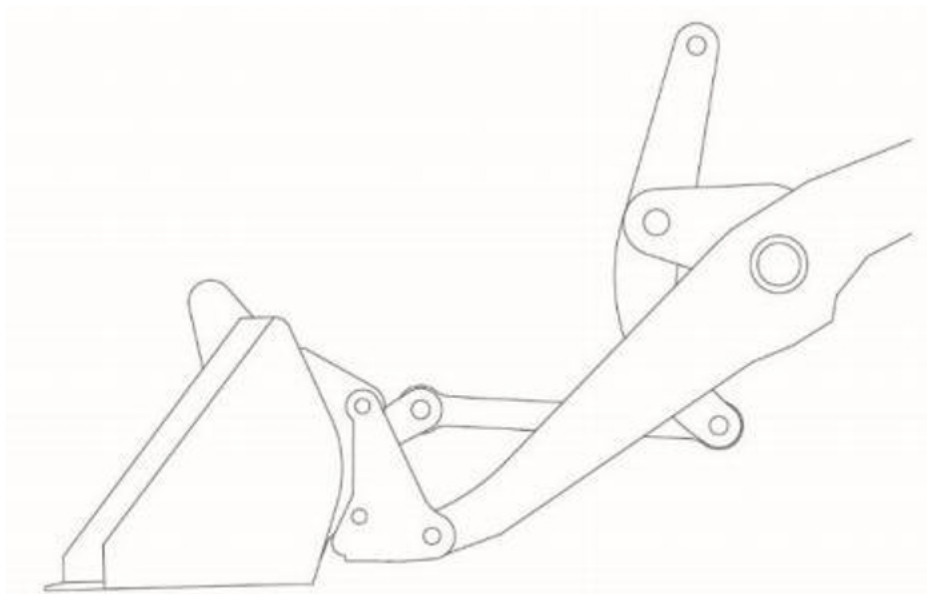

Step 2: If obstacles to the progress of the loader are found, the lift arm can be slightly lifted to continue to move forward. When adjusting the position of the lift arm, the control handle should be carried out between raise and down, and the bucket cannot be tilted forward or backward.

5.3.13 Work on flat ground

 WARNING	<ul style="list-style-type: none">• When leveling the ground, the loader should travel backwards
--	--

Step 1: Operate the handle to make the bucket is in the unloading state. The bucket posture is as shown in figure 5-51. Make the bucket lip touch the ground;

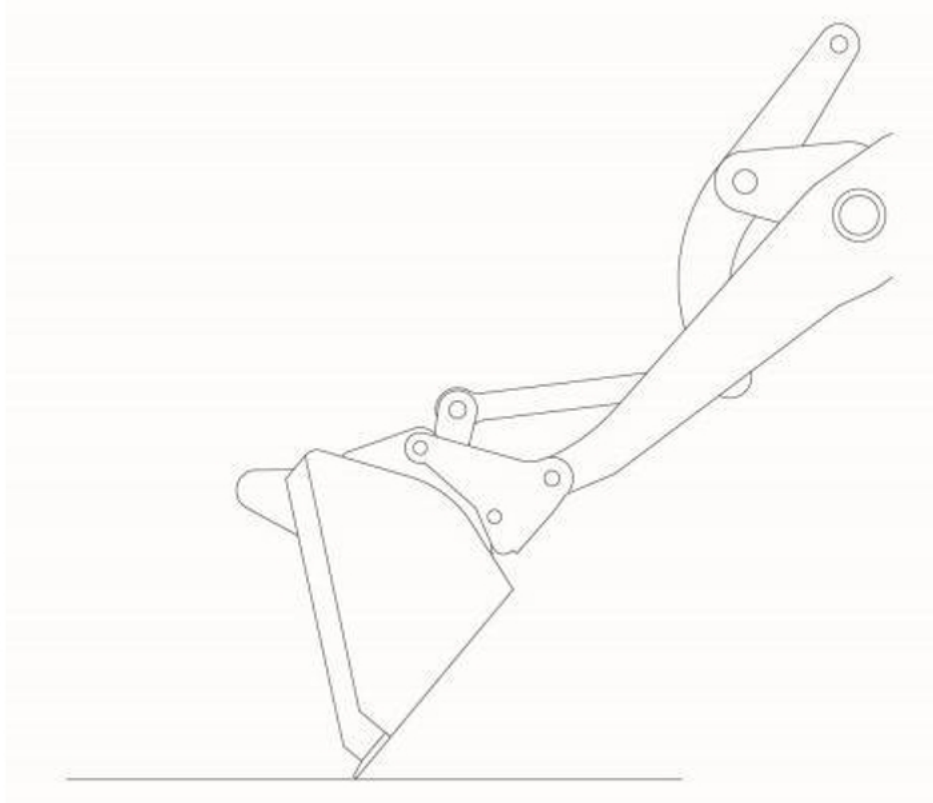

Step 2: Switch travel control switch to reverse gear, step on the accelerator pedal, make the loader back and scrape the ground.

6 Maintenance

6.1 Safety instructions

For safety maintenance of the loader, refer to this chapter.

Maintenance functions:

- Keep the loader in good condition and decrease the risk of machine failure.
- Prolonging the service life of the loader.

Do maintenance regularly referring to the contents of the manual, and record maintenance and inspection data. Maintenance includes preventive maintenance, lubrication and maintenance for long-time stop.

 <p>WARNING</p>	<ul style="list-style-type: none">• Only qualified and authorized personnel who got safety and skill training can do maintenance work.• Sufficient local lighting must be provided if maintenance or inspection requires access to the machine.• Maintenance signs must be placed around the maintenance area to warn the maintenance is in progress.• Before starting any maintenance work, make sure that the loader is completely stopped, turn starting switch to "OFF", and place "Don't start" sign in the cab.• Before maintenance, make sure that you fully understand the contents in the manual. If you have any questions, contact the technical service department of Gunter Grossmann Machinery.
---	---

6.2 Preventive maintenance

6.2.1 Maintenance list

Regular inspection and maintenance are necessary for maintaining accuracy.

Maintenance list is shown in Table 6-1.

Table 6-1 Maintenance list

No.	Item	Maintenance method
-----	------	--------------------

Every 10 hours inspection and maintenance		
01	Check for oil and water leaks.	-
02	Check if the braking system is reliable and flexible.	-
03	Check if the bolts and nuts are loose.	-
04	Check if the electrical system wiring and electrical components are operating correctly.	-
05	Check the fuel tank level.	Refer to <i>chapter 6.2.3.2</i>
06	Check the engine oil level, add as needed.	Refer to <i>chapter 6.2.3.4</i>
07	Check hydraulic oil level.	Refer to <i>chapter 6.2.3.6</i>
08	Lubricate the joint points of the loader.	Refer to <i>chapter 6.2.3.1</i>
09	Check and drain the fuel filter.	Refer to <i>chapter 5.3.9</i>
10	Check the coolant level of the water tank.	-
Every 50 hours inspection and maintenance (Do every 10 hours inspection and maintenance at the same time)		
01	Check the transmission oil level	Refer to <i>chapter 6.2.3.8</i>
03	Check the brake fluid level of the afterburner pump.	Refer to <i>chapter 6.2.3.10</i>
04	Check and tighten bolts of each driveshaft.	-
05	Check and tighten the bolts of the rim and brake caliper	-
06	Check and tighten the bolts of grab bucket tooth.	-
07	Check the accelerator pedal.	-

08	Check the control handle.	-
----	---------------------------	---

First 100 hours inspection and maintenance (Do every 10 and 50 hours inspection and maintenance at the same time)		
01	Replace fine fuel filter	Refer to <i>chapter 6.2.3.3</i>
02	Replace engine oil and filter	Refer to <i>chapter 6.2.3.5</i>
03	Replace oil and filter element of transmission.	Refer to <i>chapter 6.2.3.9</i>
04	Clean or replace the air filter element.	Refer to <i>chapter 6.2.3.13</i>
05	Replace front and rear axle gear oil.	Refer to <i>chapter 6.2.3.12</i>
06	Check or replace tires.	-
07	Check or replace grab bucket teeth.	-
Every 100 hours inspection and maintenance (Do every 10 and 50 hours inspection and maintenance at the same time)		
01	Check and clean the radiator unit.	-
02	Check and clean the fuel tank inlet filter.	-
Every 250 hours inspection and maintenance (Do every 10 , 50 and 100 hours inspection and maintenance at the same time)		
01	Replace engine oil and filter.	Refer to <i>chapter 6.2.3.5</i>
02	Check all safety devices on the loader.	-
03	Check and adjust the tension of the engine fan belt.	-
04	Check if the bolts on the working device and the front and rear frame are loose.	-
05	Check the welding seam on the working device and the frame for cracks.	-
Every 500 hours inspection and maintenance (Do every 10,50,100 and 250 hours inspection and maintenance at the same time)		
01	Replace coarse and fine fuel filter.	Refer to <i>chapter 6.2.3.3</i>

02	Replace oil and filter element of transmission.	Refer to <i>chapter 6.2.3.9</i>
03	Check the battery electrolyte level.	-
04	Check or replace shaft sleeves.	-
05	Check or replace brake pads.	-
06	Check pressures of tires.	-
<p>Every 1000 hours inspection and maintenance (Do every 10,50,100,250 and 500 hours inspection and maintenance at the same time)</p>		
01	Check and adjust the engine valve clearance.	Refer to engine repair manual.
02	Replace the air filter.	Refer to <i>chapter 6.2.3.13</i>
03	Replace hydraulic oil and it's filter element.	Refer to <i>chapter 6.2.3.7</i>
04	Replace front and rear axle gear oil.	Refer to <i>chapter 6.2.3.12</i>
<p>Every 2000 hours inspection and maintenance (Do every 10 , 50 , 100 , 250 , 500, and 1000 hours inspection and maintenance at the same time)</p>		
01	Replace the coolant.	Refer to <i>chapter 6.2.3.14</i>
02	Replace brake fluid.	Refer to <i>chapter 6.2.3.11</i>
03	By testing the natural settlement of hydraulic cylinders, check the air tightness of multi-way valves and hydraulic cylinders.	-

6.2.2 Oil selection table

 WARNING	<ul style="list-style-type: none"> • Do not mix oil of different brands and types. • Select oil according to the lowest temperature of the environment.
--	---

The recommended oils are shown in Table 6-2:

Table 6-2 Recommended oils

Category	Ambient temperature (°C)	Recommended oil	Remark
Engine oil	-40	API CF,CG-4,CH-4/SAE 5W-40	If changing oil series , please be sure to contact local dealers and agents.
	-20 to 40	API CF,CG-4,CH-4/SAE 15W-40	
	-30 to 40	API CF,CG-4,CH-4/SAE 10W-40	
Transmission oil	-30 to 40	ISO-L-HM46	
	-40	ISO-L-HS46	
Front and rear axle gear oil	-40	API GL-5/SAE 75W-90	
	-20 to 40	API GL-5/SAE 85W-90,80W-90	
Hydraulic oil	-30 to 40	ISO-L-HM46	
	-40	ISO-L-HS46	
Brake fluid		According with FMVSS NO. 116-2004 DOT4 or DOT3 Break Fluid	
Coolant		YF-2 or YF-2A	
Grease		NGLI2	

6.2.3 Typical maintenance tasks

6.2.3.1 Joint lubrication

(1) Loader lubrication point location

The joint lubrication area of the loader is divided into two areas: the working device area and the steering area, as shown in Figure 6-1.

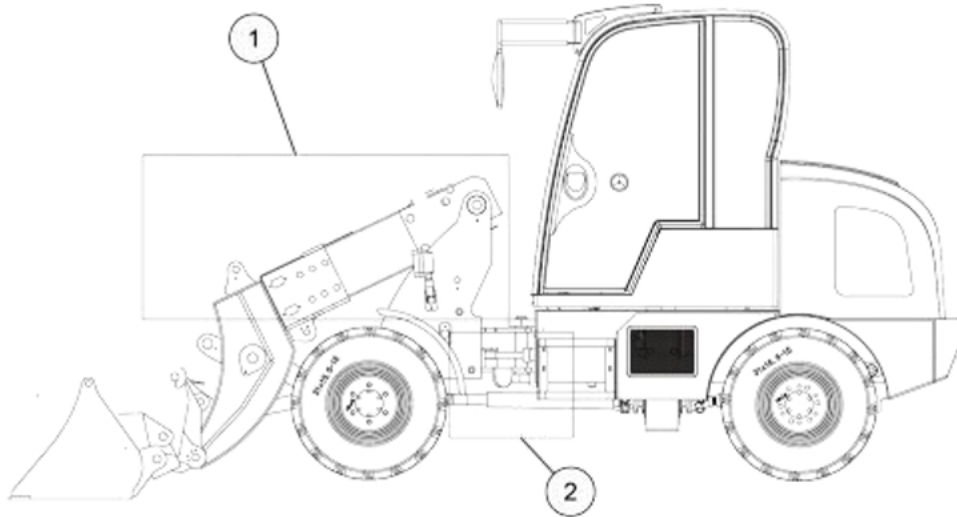

(1) Working device area (2) Steering area

The lubrication points in the working device area are shown in Figure 6-2.

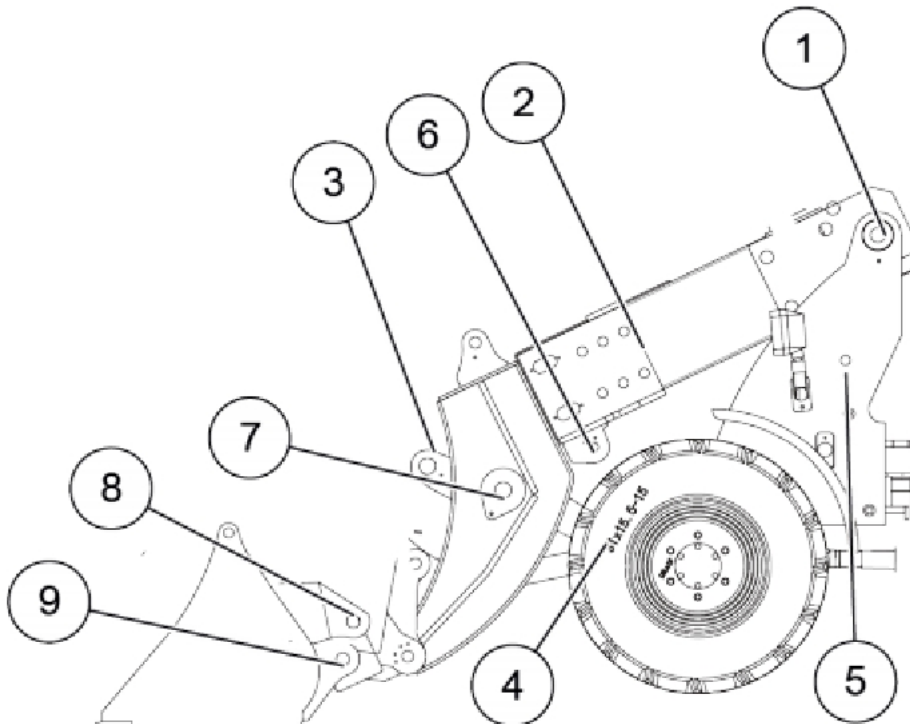

The location and number of joint lubrication points are shown in Table 6-3:

Table 6-3 Name and number of joint lubrication points

NO.	Name	Number
1	Front frame- lift arm hinge point	2
2	Rear hinge point of tipping cylinder	1
3	Front hinge point of tipping cylinder	1
4	Rocker arm-tie rod hinge point	1
5	Rear hinge point of lifting cylinder	2
6	Front hinge point of lifting cylinder	2
7	Rocker arm—lift arm hinge point	1
8	Tie rod-bucket hinge point	1
9	lift arm -bucket hinge point	2

(2)Lubrication point injection method

Step 1: Park the loader on a flat field, place the control handle in the neutral position, pull up the parking brake handle;

Step 2: Add grease with a grease gun, as shown in Figure 6-4. The specific location and quantity of lubrication points are shown in Figure 6-2, 6-3 and Table 6-3;



Step 3: Clean up waste oil.

6.2.3.2 Checking the fuel tank level

Step 1: Park loader on a flat field, place control handle in neutral position, stop and pull up parking brake handle;

Step 2: Check the fuel level from level gauge (2) outside. When the fuel is below the lower limit, unscrew the cap (1) to add fuel. The fuel shall not exceed the upper limit of level gauge (2), as shown in Figure 6-5;

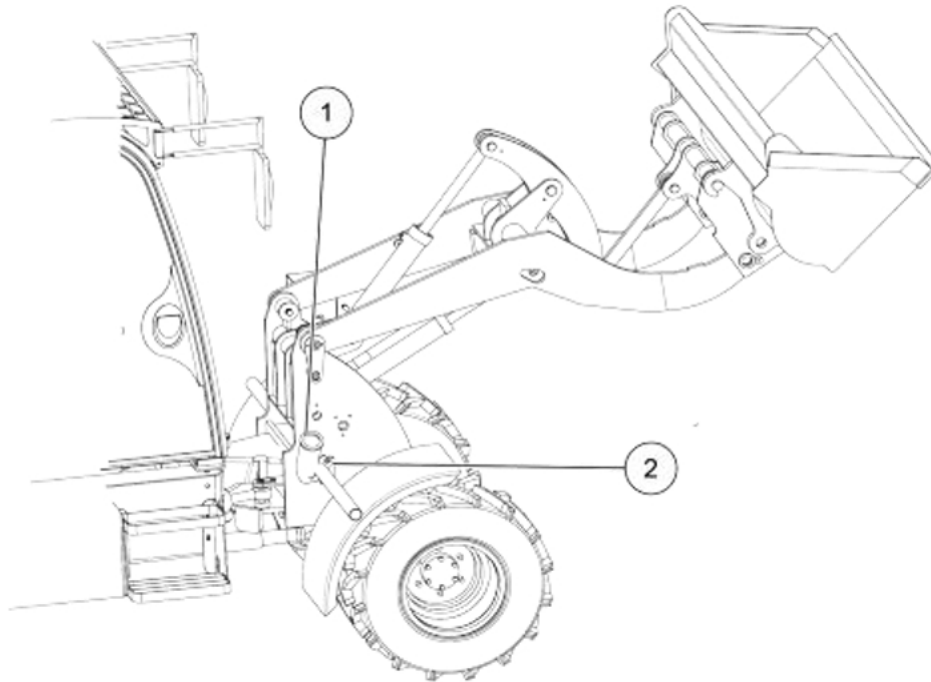

(1) Cap (2) Level gauge

6.2.3.3 Replacing fuel filter

Step 1: Park loader on a flat field, place control handle in neutral position, stop and pull up parking brake handle;

Step 2: Open the engine hood;

Step 3: Unscrew the primary fuel filter (1) (2) with a filter wrench, and place a container under the filter to prevent fuel splashing, as shown in Figure 6-6;

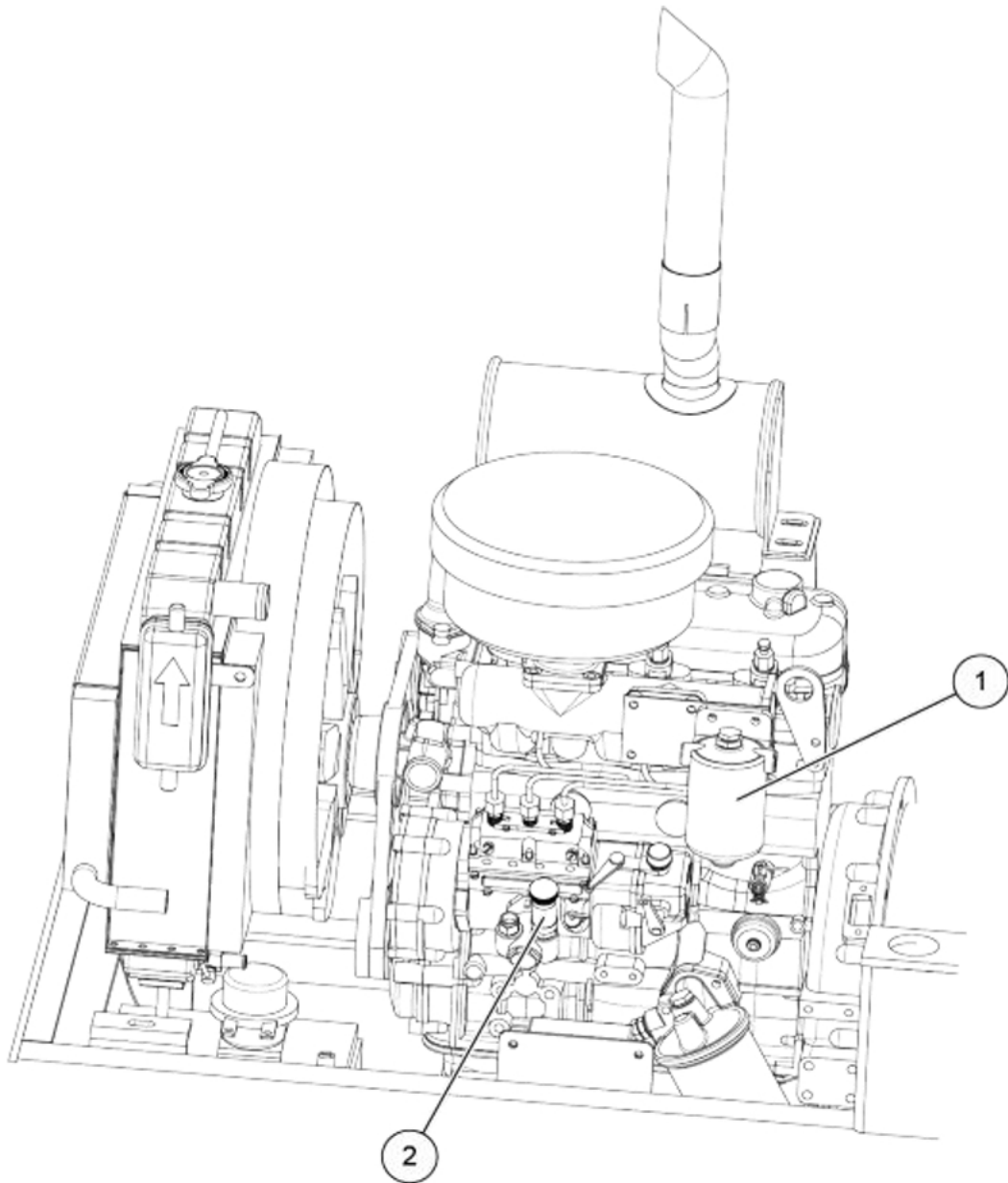

(1) Primary fuel filter (2) Hand pump button

Step 4: Apply a layer of engine oil to the new filter seals, install and tighten the new filters with a filter wrench;

Step 5: Press again and again until feeling pressure in the hand pump, then pump about 20 strokes to finish the exhaust of the fuel system;

Step 6: Close the engine hood, start the loader, and run it at idle speed for 5 minutes. If starting difficult, exhaust the engine fuel system again.

6.2.3.4 Checking the engine oil level

Step 1: Park loader on a flat field, place control handle in neutral position, stop and pull up parking brake handle, put the blocks before and after the tires, as shown in Figure 6-7;

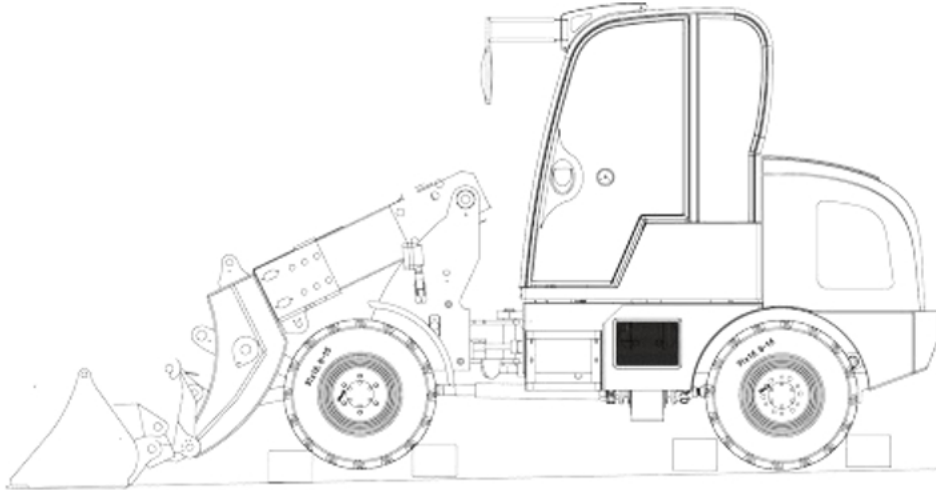

Step 2: Open the engine hood;

Step 3: Pull out and clean the oil dipstick (1), insert it completely, and then take it out as shown in Figure 6-8;

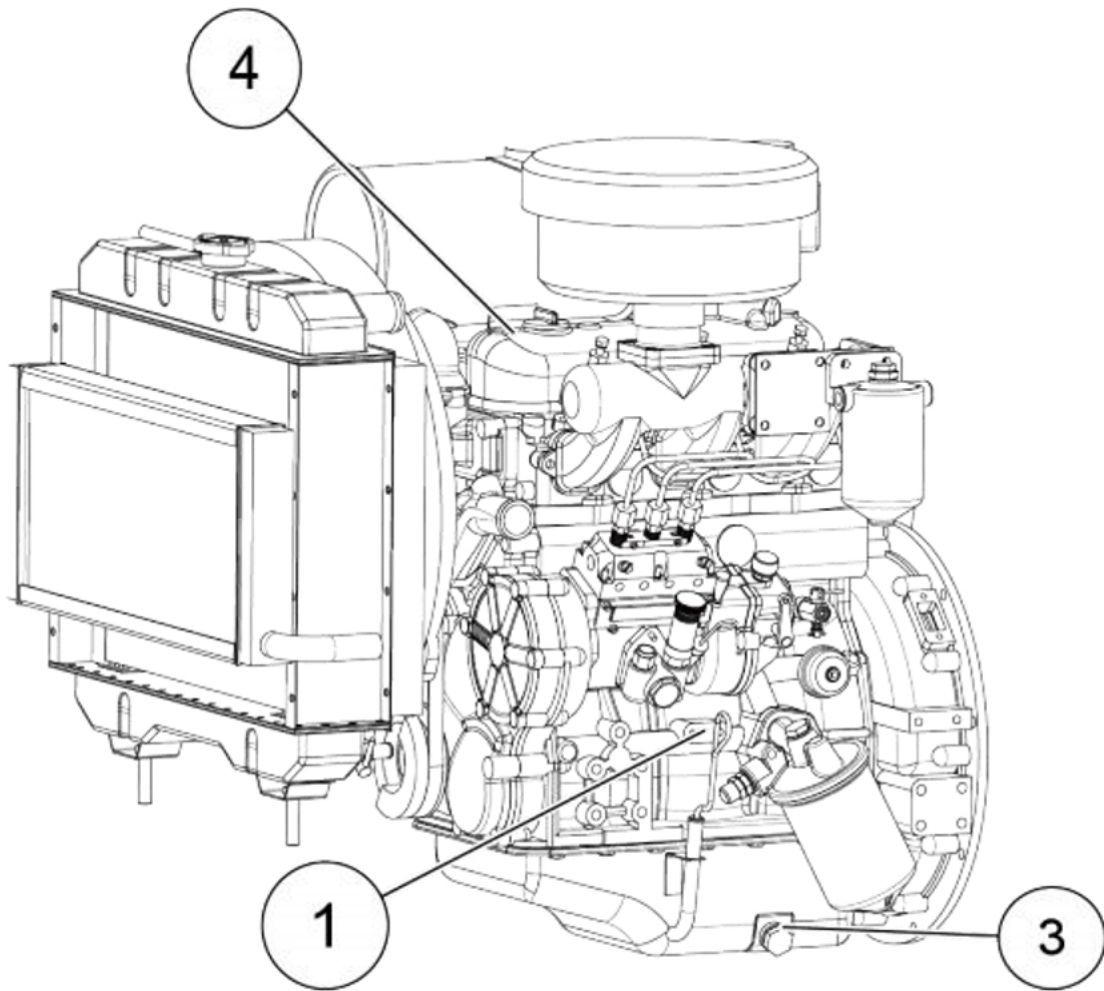

(1) Oil dipstick

Step 4: Check and record the oil level, and insert the oil dipstick back as shown in Figure 6-9;

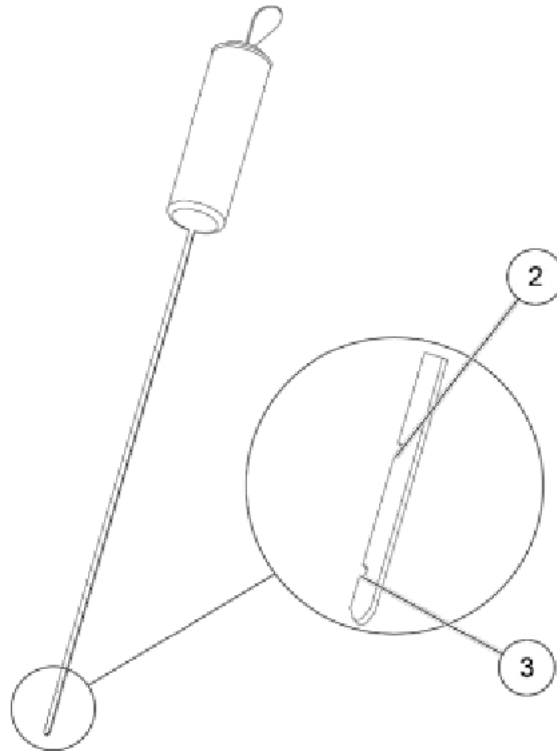

(2) Upper limit mark (3) Lower limit mark

Step 5: When the oil level is higher than the upper limit mark, unscrew the oil plug (4) to drain the excess oil; when the oil level is lower than the lower limit mark, add oil from the oil filler port (5) as shown in Figure 6-10;

(4) Oil plug (5) Oil filler port

Step 6: Repeat the above steps until the oil is between the upper and lower limit marks;

Step 7: Close the engine hood.

6.2.3.5 Replacing engine oil and filter

Step 1: Park loader on a flat field, place control handle in neutral position, stop and pull up parking brake handle, put the blocks before and after the tires, as shown in Figure 6-11;

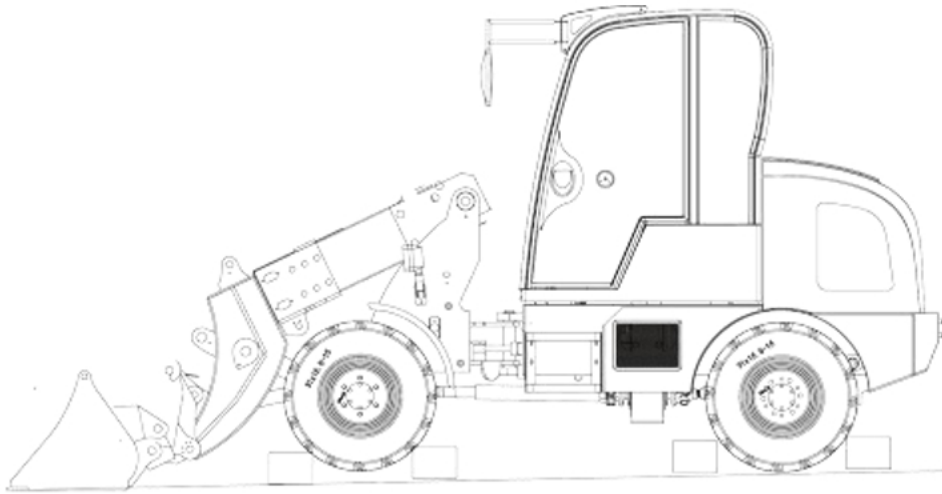

Step 2: Start the engine, and after idling for 10 minutes, stop the engine;

Step 3: Open the engine hood, unscrew the oil plug (1), and place a container under the engine to prevent oil splashing. After draining the old oil, tighten the oil plug, as shown in Figure 6-12;

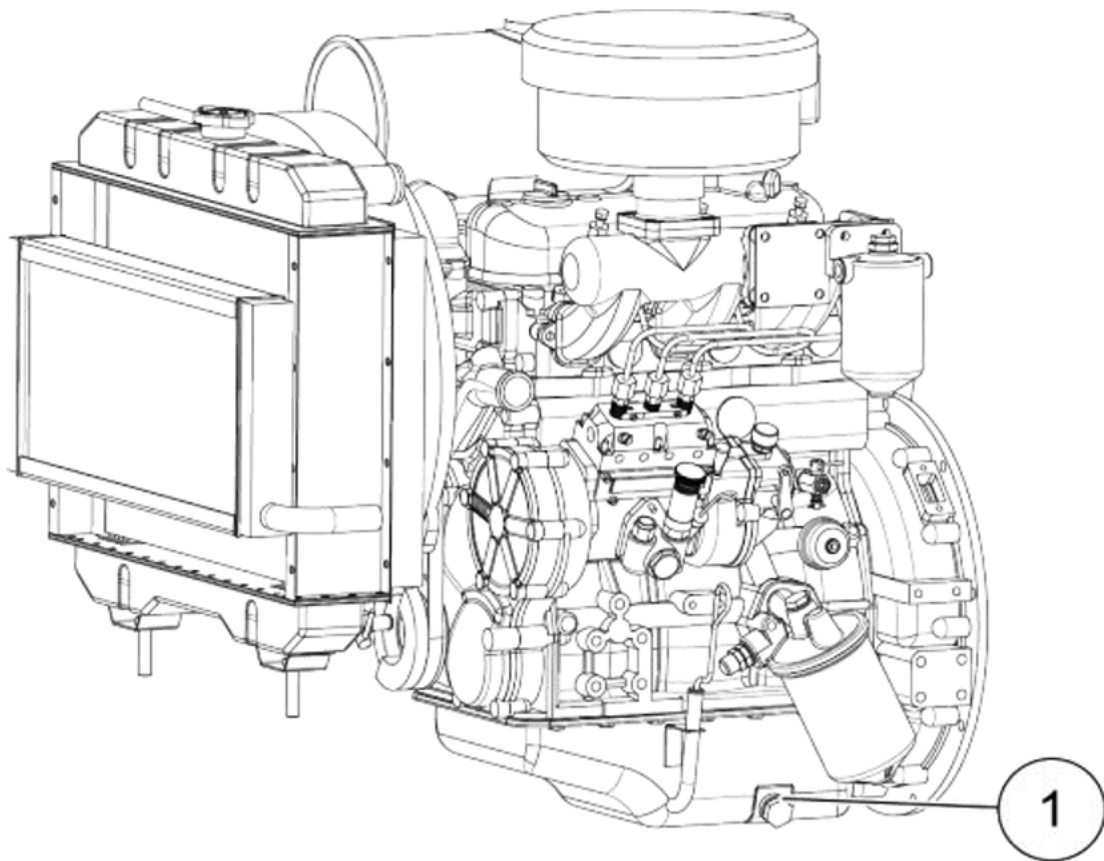

(1) Oil plug

Step 4: Clean the dust around the filter mounting seat, unscrew the oil filter (2) with a filter wrench as shown in Figure 6-13;

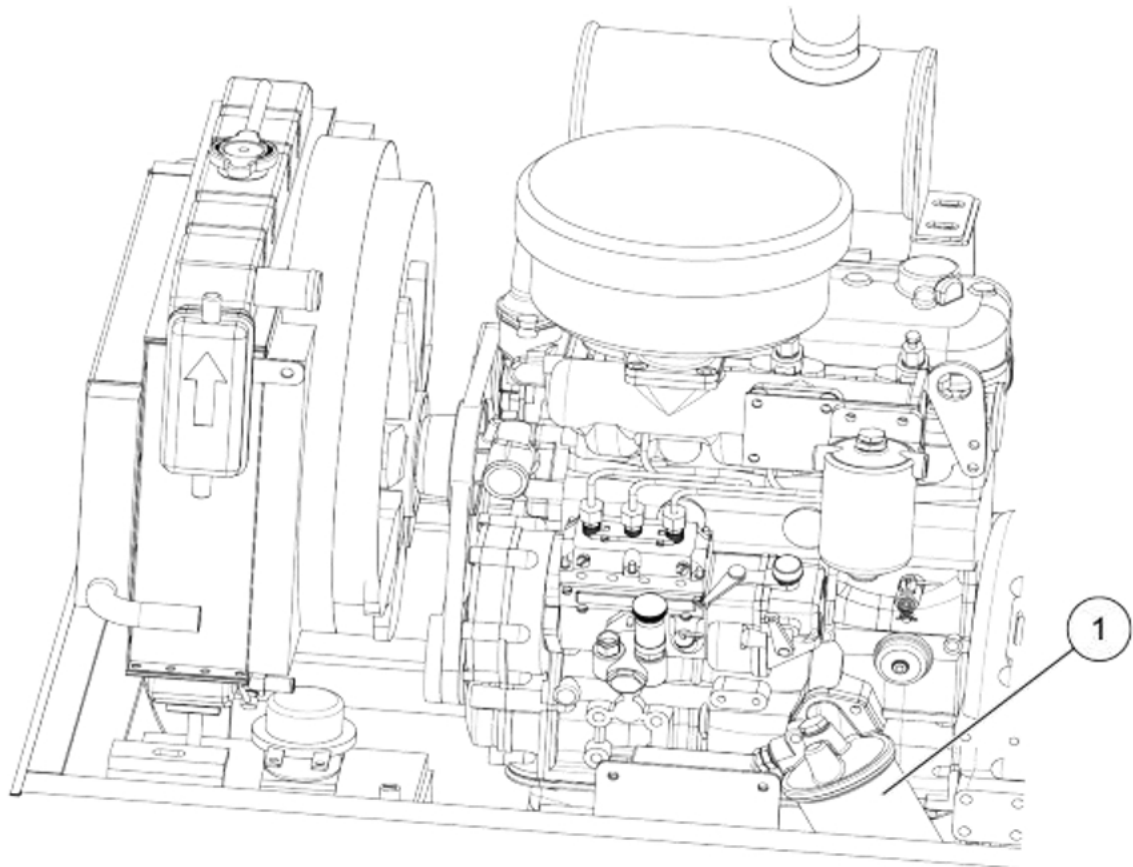

(2) Oil filter

Step 5: Apply a layer of engine oil to the new filter seals, install and tighten the new filters with a filter wrench;

Step 6: Unscrew the oil filler cap (3), and add oil. The amount of oil is about 6.8 kg, as shown in Figure 6-14;

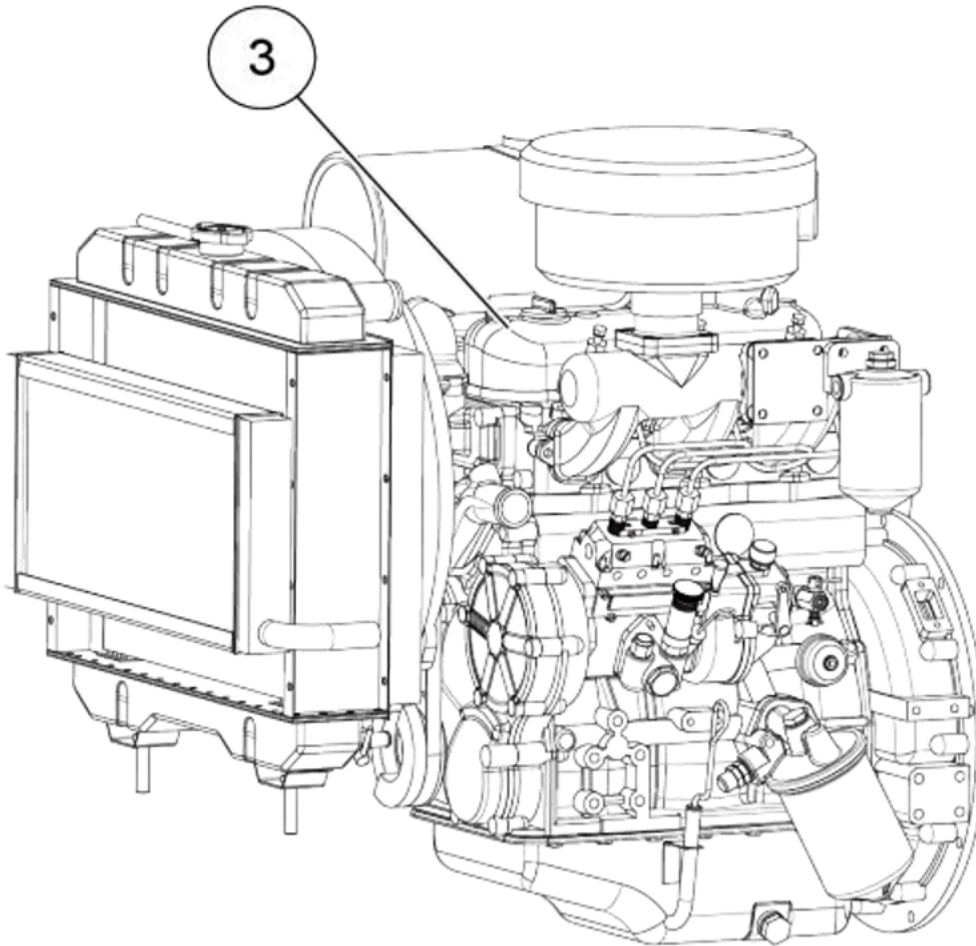

(3) The oil filler cap

Step 7: Start the engine and check for oil leakage;

Step 8: After the engine is turned off for 15 minutes, check the engine oil level through the oil dipstick, refer to *chapter 6.2.3.4 checking the engine oil level*;

Step 9: Close the engine hood.

6.2.3.6 Checking hydraulic oil level

Step 1: Park loader on a flat field, place control handle in neutral position, stop and pull up parking brake handle;

Step 2: Check the hydraulic oil level from the oil level gauge (1). When the hydraulic oil is below the lower limit, add hydraulic oil from the oil tank filler port (2). The hydraulic oil should not exceed the upper limit, as shown in Figures 6-15 .

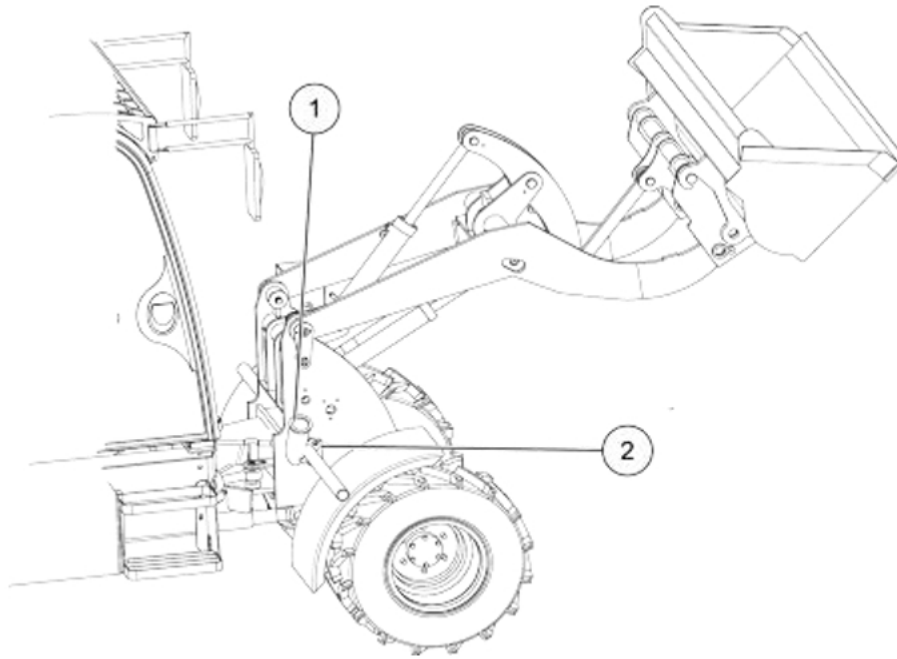

(1) Hydraulic oil level gauge

(2) Filling port of hydraulic oil tank

6.2.3.7 Replacing hydraulic oil and filter element

	<ul style="list-style-type: none">• Change the oil after the oil has cooled.• Turn the filler cap slowly to release the internal pressure before removing it.
---	--

Step 1: After starting the engine, turn left and right, lift and down the bucket, tilt the bucket back and forth, and repeat these actions for about 10 minutes;

Step 2: Park loader on a flat field, place control handle in neutral position, stop and pull up parking brake handle, put the blocks before and after the tires, as shown in Figure 6-17;

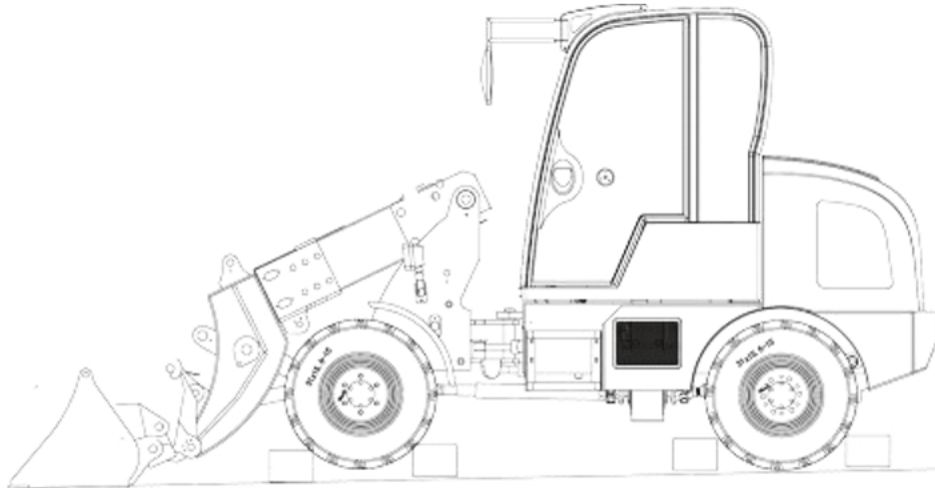

Step 3: Open the engine hood;

Step 4: Unscrew the oil drain plug to drain the old oil, and use a container to hold it,

Step 5: Remove the radiator and other obstructive devices, remove the cover check and clean the oil tank;

Step 6: Unscrew the hydraulic oil filter element in the tank, and install a new one.

Step 7: Install the cover, install the radiator and other obstructive devices;

Step 8: Unscrew the hydraulic oil tank cap, add hydraulic oil not exceed the upper limit of the level gauge, and then install the hydraulic oil tank cap;

Step 9: Remove the blocks, start the loader, turn left and right, lift and down the bucket, tilt the bucket back and forward at a lower speed;

Step 10: Remove the hydraulic oil tank cap after shutdown, add hydraulic oil to the upper limit, and then tighten the oil tank cap;

Step 11: Close the engine hood.

6.2.3.8 Checking the transmission oil level

Step 1: Park loader on a flat field, place control handle in neutral position, stop and pull up parking brake handle;

Step 2: Start the engine, run at idle speed for 2 to 3 minutes and then stop. When the oil temperature is 50°C to 60°C, the oil level of the transmission oil level gauge (1) should be in the middle position, as shown in Figure 6-22;

(1) Oil level gauge (2) Oil plug

Step 3: when the oil level is lower than the lower limit, (3) and add transmission oil from the oil filler port (4); when the oil level exceeds the upper limit,unscrew the oil plug (2) to drain the excess oil, as shown in Figure 6-23;

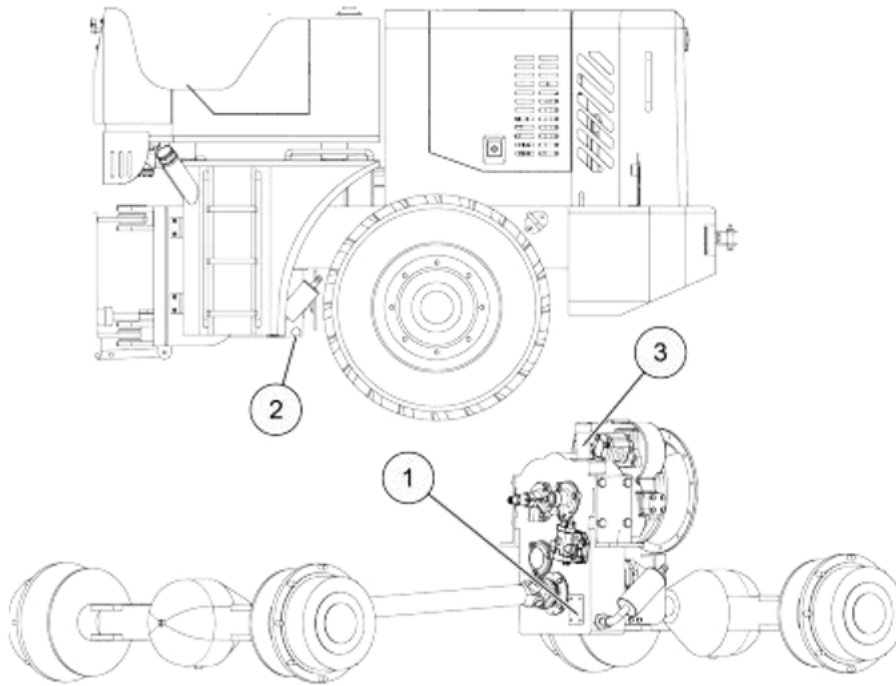

(3) Oil filler port

6.2.3.9 Replacing transmission oil and filter element

 WARNING	<ul style="list-style-type: none">• The temperature of transmission oil will be very high after long-term operation, and oil must be replaced after oil has been cooled.
--	--

Step 1: Park loader on a flat field, place control handle in neutral position, stop and pull up parking brake handle,put the blocks before and after the tires, as shown in Figure 6-24;

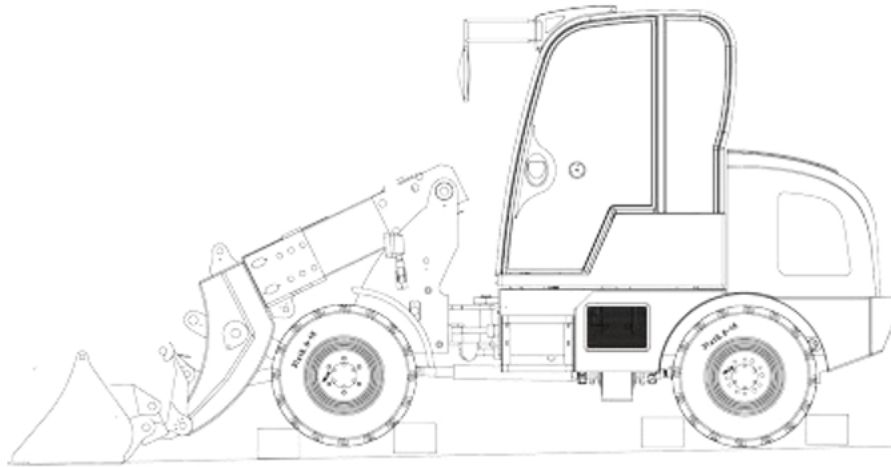

Step 2: Unscrew transmission oil plug and drain oil into container, tighten the plug after completion;

Step 3: Loosen two bolts remove and fix oil pipe

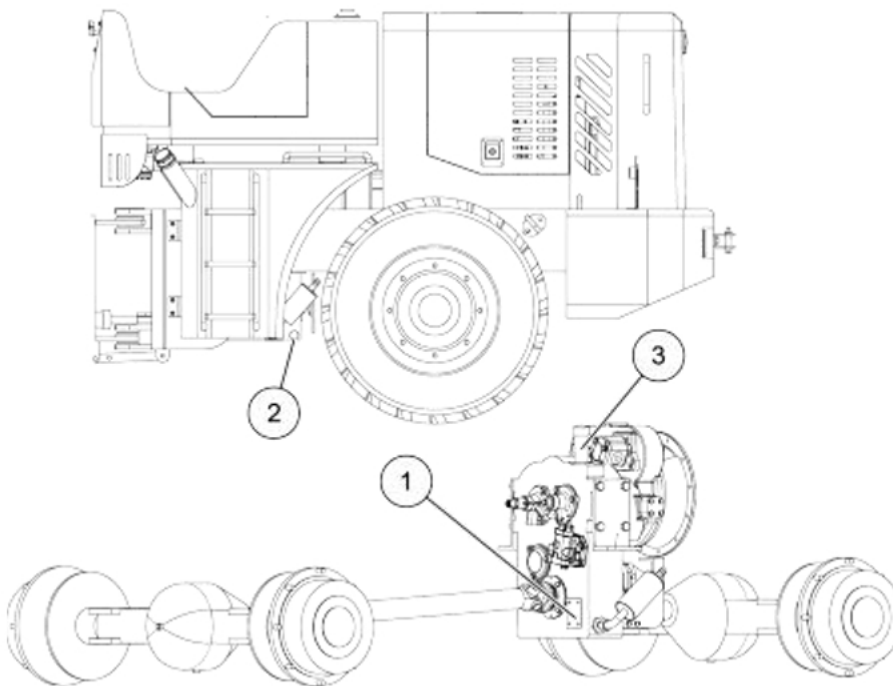

(1)Oil level gauge (2) Transmission oil plug Bolt (3) Oil filter port

Step 4: Unscrew the mounting frame with a wrench, replace with a new hydraulic oil filter element, and then tighten mounting frame ;

Step 5: Install oil pipe and tighten bolt ;

Step 6: unscrew oil filler cap , add transmission oil through the oil filler port until the oil level gauge reaches to middle position.Tighten oil filler cap , as shown in Figures 6-25

Step 7: Start the engine and run at idle speed for 2 to 3 minutes, then stop it. Recheck transmission oil level. Refer to *chapter Checking the transmission oil level* to ensure that transmission oil level is not higher than upper limit of oil level gauge.

6.2.3.10 Checking the brake fluid level

Step 1: Park loader on a flat field, place control handle in neutral position, stop and pull up parking brake handle;

Step 2: Open the engine hood and check the brake fluid level.If the brake fluid is lower than 1/3 of the height of the brake fluid tank (1), add the same type of brake fluid.The brake fluid should not be higher than 2/3 of the height of the brake fluid tank, as shown in Figure

6.2.3.11 Replacing brake fluid

 WARNING	<ul style="list-style-type: none">• Never mix brake oil of different brands.• Brake oil is corrosive to a certain extent. When replacing brake oil, must wear protective gloves, protective glasses and protective clothing.
--	---

Step 1: Park loader on a flat field, place control handle in neutral position, pull up parking brake handle, and put the blocks before and after the tires, as shown in Figure 6-28;

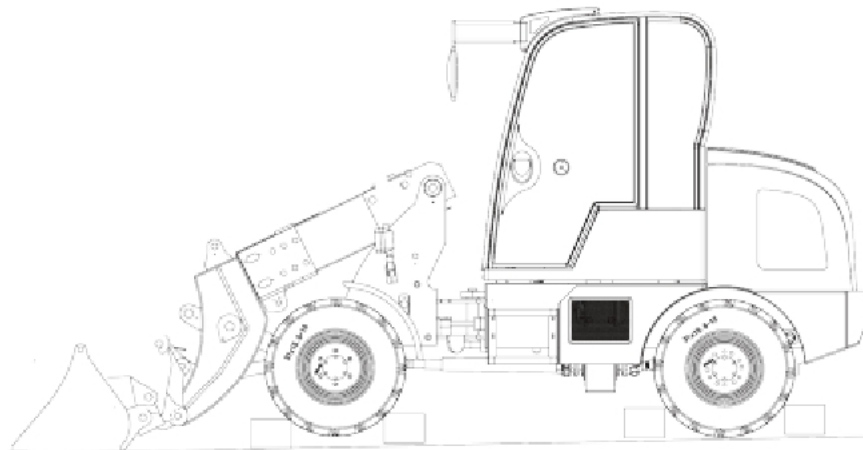

Step 2: Open engine hood;

Step 3: A person under loader, loosen oil plug and install two ends of transparent hose in oil drain and container

Step 4: Another person repeatedly steps on brake pedal in cab, brake fluid will flow out from oil drain; At the same time, people under loader add new brake fluid to brake fluid tank, and tighten oil plug after clear fluid flow out of oil drain

Step 5: Replace brake fluid of other three wheels, the operation sequence of four wheels is front left, rear right, front right, and rear left;

Step 6: After four wheels are replaced, start machine to test braking effect. If brake function is found to be soft and not sensitive, please execute steps 7 in sequence; If brake function is normal, end operation of replacing brake oil;

Step 7: The person in cab steps on and hold brake pedal to deepest position, the person under loader loosens oil plug. After brake fluid is sprayed out, tighten oil plug and notify person in cab to release brake pedal. Repeat the above operation several times until there are no air bubbles in brake oil.

6.2.3.12 Replacing front and rear axle gear oil

Step 1: Drive the loader onto a flat field, slowly move the loader to let the oil plug (1) at the lowest position, as shown in Figure 6-31:

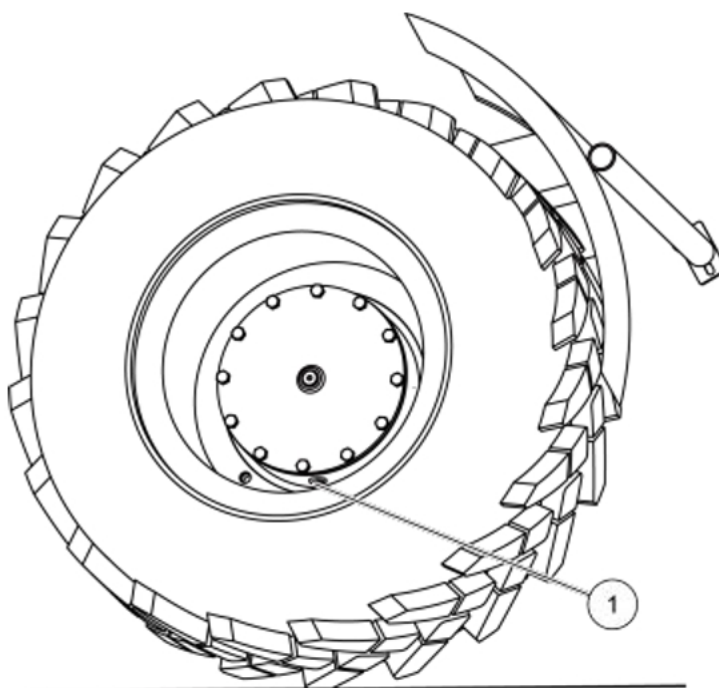

(1) Oil plug/ port

Step 2: Stop loader, place control handle in neutral position, pull up parking brake handle, put the blocks before and after the tires, as shown in Figure 6-32:

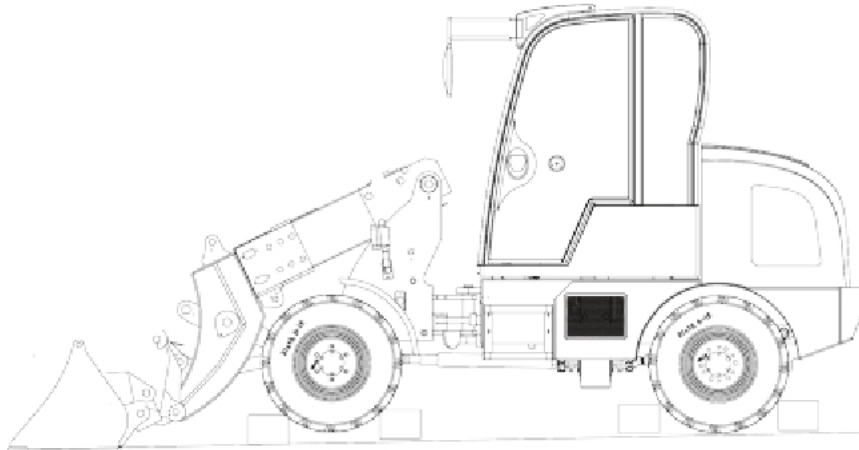

Step 3: Unscrew the oil plugs (1) and (3), use a container to hold old oil. Tighten the two oil drain plugs finally, as shown in Figure 6-33:

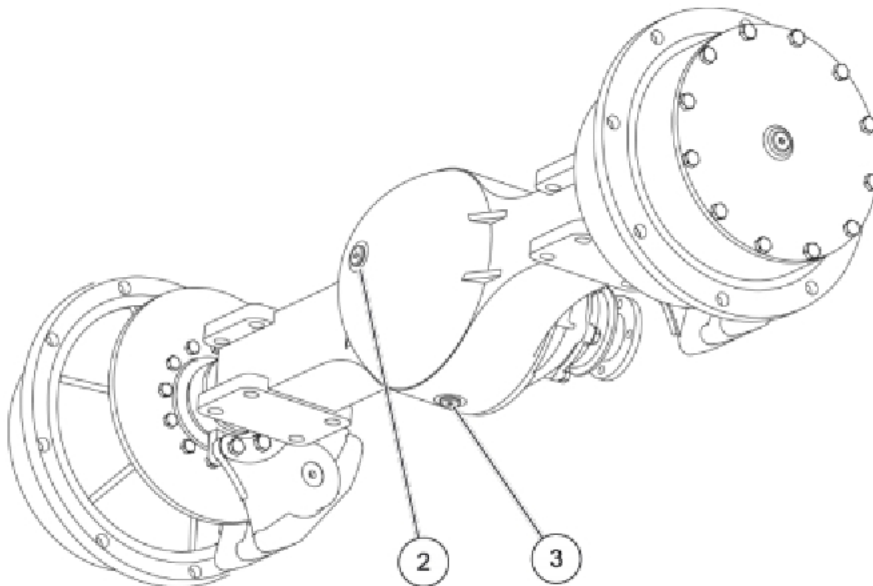

(2) Oil plug/ port (3) Oil plug/ port

Step 4: Start the engine, remove the blocks, slowly move the loader to let the oil plug (1) at a horizontal position. Stop and pull up the parking brake handle, and place the blocks on the front and back of the tire, as shown in Figure 6-34:

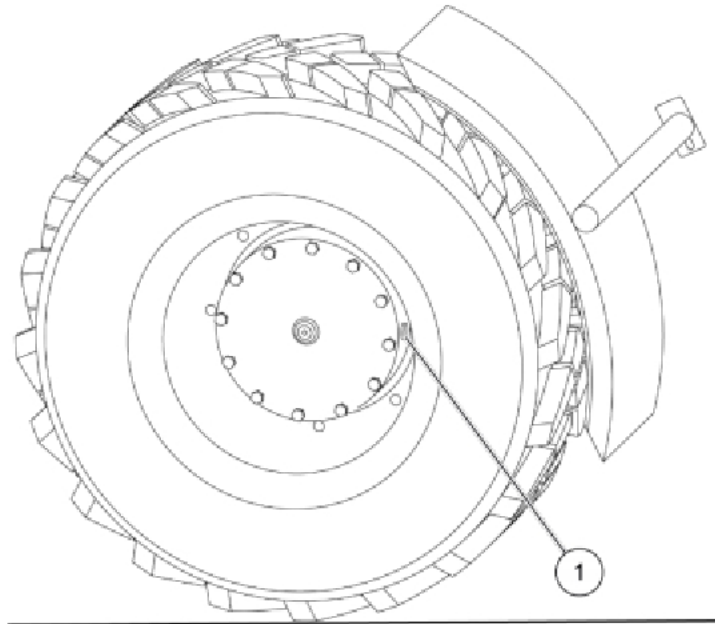

(1) Oil plug/ port

Step5: Add the specified type of gear oil from the oil port (1) and (2) to the lower edge of the oil port, and then tighten the oil plug;

Step6: According to the above process, replace the rear axle gear oil.

6.2.3.13 Replacing the air filter element

Step 1: Park loader on a flat field, place control handle in neutral position, stop and pull up parking brake handle;

Step 2: Unscrew the nut of the air filter, and remove the filter cover , as shown in Figure

Step 3: Unscrew the nut and remove the cover of mounting frame

Step 4: Replace the new air filter element and install the remaining parts in the reverse order.

6.2.3.14 Replacing the coolant

 WARNING	<ul style="list-style-type: none">• Unprotected skin is at risk of scalding and severe burns.• After machine has been running for a long time, water tank is under high temperature and high pressure. Do not remove water tank cover before water tank is cooled.• The coolant is corrosive to a certain extent, so must wear protective gloves, protective glasses and protective clothing when replacing coolant.
--	--

Step 1: Park loader on a flat field, place control handle in neutral position, stop and pull up parking brake handle;

Step 2: Open the engine hood;

Step 3: After the engine is sufficiently cooled down, slowly unscrew the cap (1), as shown in Figure 6-37;

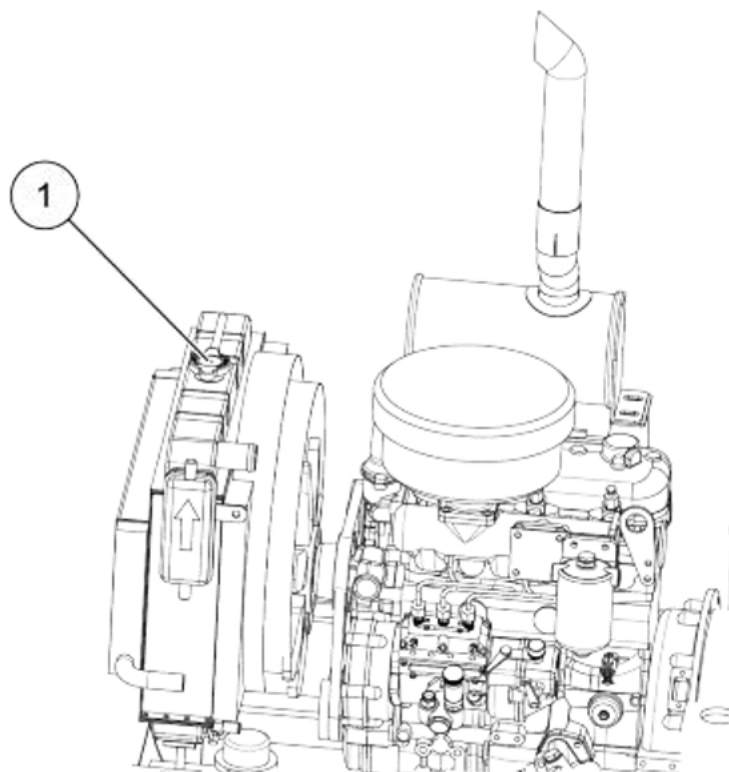

Step 4: The coolant drain point is at the lower left corner of the radiator, open the drain valve(2) to drain the old coolant into container, as shown in Figure 6-38;

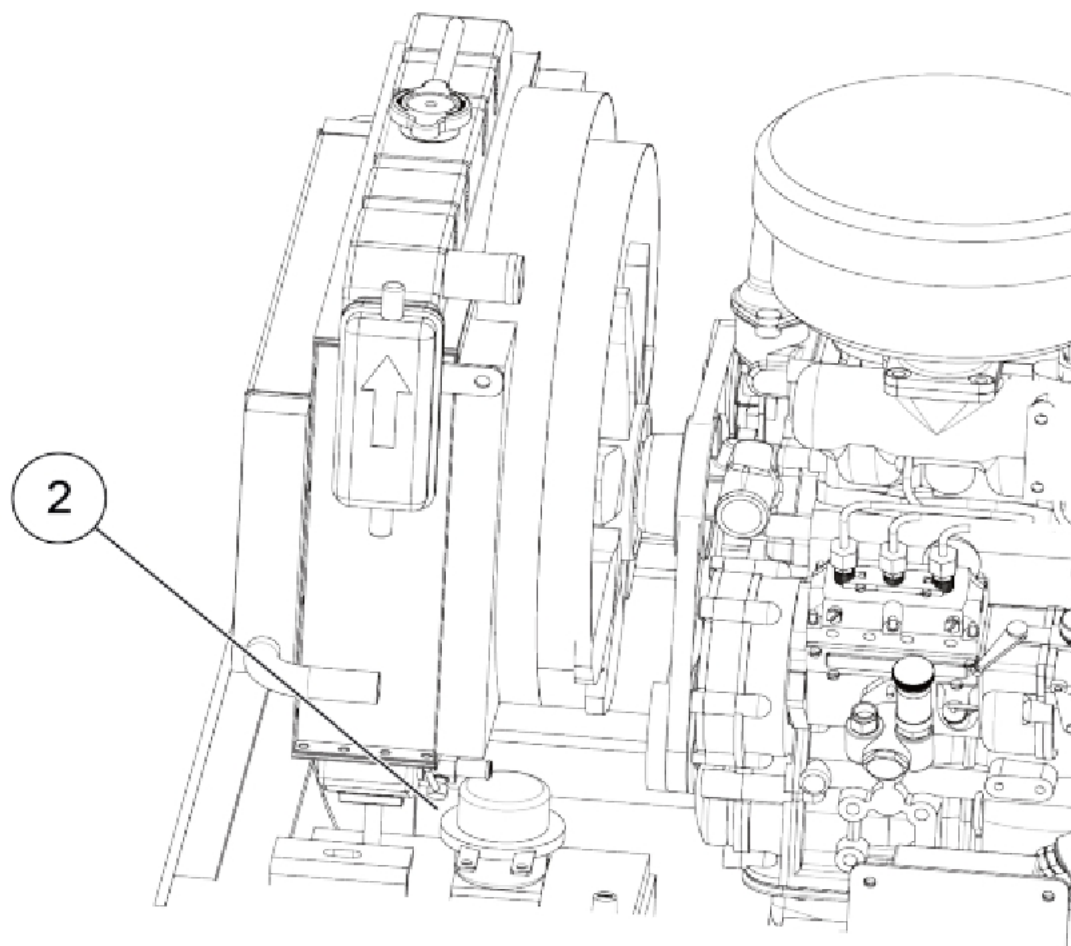

(2) Drain valve

Step 5: Tighten the drain valve (2), add the coolant to the upper limit, and tighten the cap (1);

Step 6: Start the loader, run at idle speed for 2 to 3 minutes and then stop;

Step 7: After the engine is sufficiently cooled, remove the cap (1), and add the coolant to the upper limit.

6.2.3.15 Checking and adding cleaning fluid

Step 1: Park loader on a flat field, place control handle in neutral position, stop and pull up parking brake handle;

Step 2: Check cleaning liquid level in cleaning liquid tank (1). If liquid level is lower than 1/3 of height of cleaning liquid tank, add same type of cleaning liquid, and cleaning liquid level should not be higher than 2/3 of height of hydraulic tank, as shown in Figure 6-39;

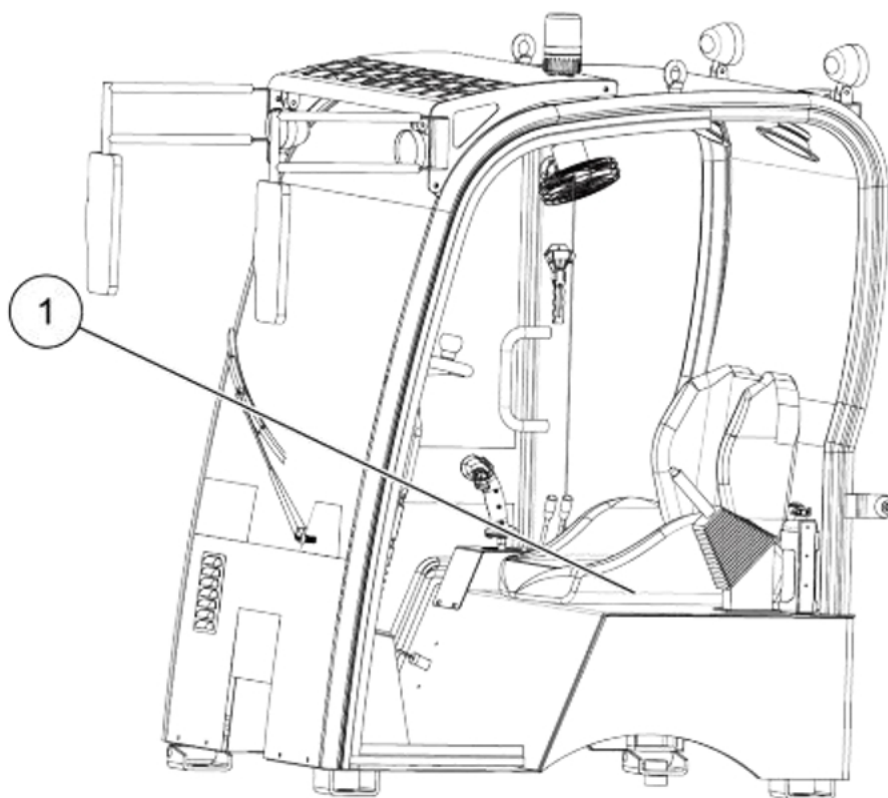

(1) Cleaning liquid tank

6.3 Maintenance for long-time stop

6.3.1 Before long-time stop

Do these inspections and maintenance when the loader is stopped for more than two weeks.(1)
After cleaned, place the loader in a dry building. If placed outdoors, park it on a concrete floor that is easy to drain and cover it with canvas.

(2)Add fuel oil, hydraulic oil, grease; and replace with new engine oil.

(3)Replace coolant.

(4)Apply grease to exposed parts (such as the exposed part of the cylinder piston rod).

(5)Remove the negative electrode of the battery, or remove the battery from the loader, and store it separately.

(6)Check the tire pressure and avoid exposure to strong light.

6.3.2 During longtime stopping

Do these inspections and maintenance during the loader is stopping more than two weeks.

(1) Start the engine once a week, and after a sufficient warm-up operation, move the loader forward and backward. Before the accessory moved, clean the grease added on the piston rod at first. After finished, add grease again.

(2) Raise the loader to keep the tires off the ground; if not, check and Inflate the air pressure every two weeks.

(3) Check the battery voltage and charge it once a month.

6.3.3 Starting after long-time stop

Do these inspections and maintenance before starting the loader that has been stopped for more than two weeks.

(1) Remove the cover.

(2) Clean the grease added to the exposed part.

(3) Install the battery and connect with the cable.

(4) Adjust the tire pressure according to the specified.

(5) Do inspections before starting.

(6) Add grease to each joint.

(7) Do a sufficient warm-up.

(8) Run the engine at low speed to exhaust the air in the hydraulic system, and operate as follows: each hydraulic cylinder extends and retracts 4 to 5 times, and the piston stops at 100mm from the end of the stroke. Then each hydraulic cylinder is extended and retracted 3 to 4 times in full stroke.

 WARNING	<ul style="list-style-type: none">• If the engine is running at high speed or the piston is running at full stroke at the beginning, the air mixed in may damage the cushion of the cylinders.
--	--

