

GG016T

TELESCOPIC LOADER

The GG016T telescopic loader is equipped with a powerful and reliable diesel engine with a rated speed of 2400 rpm, ideal for heavy-duty tasks. It reaches speeds of 18–28 km/h, ensuring good mobility on construction sites. Standard 20.5/70-16 tires (optional 33X16.5-15) provide excellent traction and comfort in tough terrain. With a load capacity of 1600 kg and a 0.8 m³ bucket, the GG016T efficiently handles heavier materials. Its compact design and short 1500 mm wheelbase offer outstanding maneuverability in tight spaces, helping to speed up work completion.

With a hydraulic pressure of 16 MPa and a hydraulic oil flow of 60 l/min, the GG016T is capable of performing tasks requiring high hydraulic power. The high efficiency of the hydraulics allows for fast and effective operations, giving the user full control over the machine.

■ Specification

Bucket Capacity	0,8m3
Engine	Diesel
Optional Tires	33X16,5-15
Hydraulic Oil Flow	60l/min
Weight	4000kg
Standard Tire	20.5/70-16
Hydraulic Pressure	16 Mpa
Max Driving Speed	18-28 km/h

■ Work Range

Load Capacity	1600 kg
Wheelbase	1500 mm
Rated Speed	2400 rpm
Tread	2280 mm

■ Main Dimensions

Length	5480 mm
Height	2580 mm
Width	1850 mm

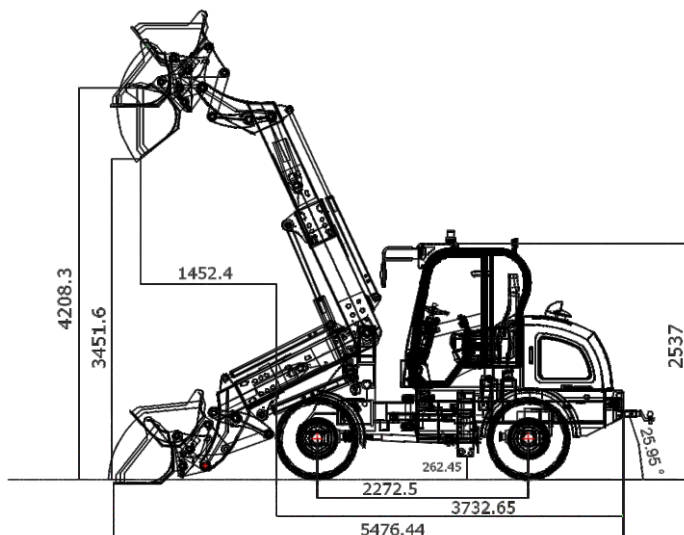

■ Additional equipment (for reference)

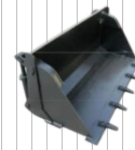

4-in-1 Bucket



Grapple (Crocodile-type)



Pallet Forks



Grass Grab



Bale Grab



Snow Plow



Mower



Sweeper

